

ARROW

RESTAURANT EQUIPMENT

(909) 621-7428 | www.ArrowRestE.com

5061 E Arrow Hwy, Montclair, CA 91763



REFRIGERATION
EQUIPMENT
COUNTER EQUIPMENT
WAREWASHING
STORAGE & TRANSPORT
FURNITURE & MORE

Everything Your Busy Kitchen Needs—All in One Place

EQUIPMENT

Version #26

ESSENTIALS

Dear Valued Customer:

We have built a reputation based on our commitment to offer the highest quality products at the most competitive prices in the marketplace.

With this commitment comes professional, personal service and the expertise of our entire staff. Many of the items in our catalog are stocked, while other unique items shown require special order. In most cases, the items shown can fulfill all your foodservice equipment and supply needs, but if you are unable to find exactly what you desire, please contact one of our associates who will happily assist you.

We value and appreciate your business. Thank you for allowing us the opportunity to serve you.



**REFRIGERATION
EQUIPMENT
COUNTER EQUIPMENT
WAREWASHING
STORAGE & TRANSPORT
FURNITURE & MORE**



Our company is a Dealer in PCR - Pride Centric Resources, one of the largest buying groups of food service equipment and supplies. As a PCR Dealer, we are able to combine our purchases with more than 90 other independent distributors to attain the best prices in the marketplace, and thereby pass on great savings to you, our valued customer.

WE APPRECIATE YOUR SUPPORT!

ARROW
RESTAURANT EQUIPMENT

(909) 621-7428 | www.ArrowRestE.com

5061 E Arrow Hwy, Montclair, CA 91763

NOTE: We are not responsible for typographical errors. Illustrations may differ from products available. We may substitute comparable or better merchandise for out of stock or discontinued items.

Table of Contents

4-41	Refrigeration
42-49	Ice Machines
50-81	Equipment
82-84	Kitchen Ventilation
85-116	Counter Equipment
117-125	Food Prep
126-127	Worktables
128-134	Storage & Transport
135-136	Janitorial
137-151	Warewashing
152-164	Bar
165-172	Buffet
173-180	Furniture



Countertop Soft Serve Freezers

- Fast freeze down and recovery times with a patented high efficiency heat exchanger
- Exclusive Controlled Contact Flooded Evaporator
- V5 single-piece auger
- Gravity feed or air pump pressurized dispensers
- Independent digital control system automatically regulates and maintains consistent product quality on each side
- Refrigerated hoppers with standby mode that maintains safe product temperatures below 40°F and agitation keeps product fresh overnight
- Temperature display, low mix indicator light, and dispensing speed control features
- Single flavor or a 2 flavor and a twist design



6235A-C



GRAVITY FEED	FLAVORS	SERVINGS PER HOUR	DIMENSIONS
6210-C	1	120	11½" w x 25¾" d x 29¾" h
6236-C	1	350	17¾" w x 26¾" d x 38" h
6235-C	2 w/ 1 Twist	350	21" w x 25¾" d x 37¾" h
PRESSURIZED AIR PUMP FEED			
6236A-C	1	350	17¾" w x 26¾" d x 38" h
6235A-C	2 w/ 1 Twist	350	21" w x 25¾" d x 37¾" h

Patented freezing system creates a smooth, creamy texture

Floor Standing Twin Twist Soft Serve Freezers

- Dispenses two flavors and a combination twist of soft serve, yogurt or sorbet
- Refrigerated hoppers with integrated agitators
- Floor-standing design with heavy-duty locking casters
- Easy to use digital control system
- Temperature display
- Standby/sleep mode
- Auto closing dispensing valve
- Dispensing speed control
- Low mix indicator light
- Ideal for medium or high output
- 2 flavors + 1 twist



6378-C



6378A-C

GRAVITY FEED	SERVINGS PER HOUR	DIMENSIONS
6250-C	350	21" w x 25¾" d x 58" h
6378-C	700	25" w x 27¾" d x 63" h
PRESSURIZED AIR PUMP FEED		
6250A-C	350	21" w x 25¾" d x 58" h
6378A-C	700	25" w x 27¾" d x 61½" h

Serve up something sweet.



MBF8003GR

MBF8004GR



Reach-Ins

- Stainless steel exterior & interior
- Full Electronic Controller
- LED interior lighting
- Solid swing door(s) with recessed door handle(s)
- Door lock(s) standard
- Magnetic door gasket(s) standard for positive door seal
- Pre-installed casters
- Refrigerators maintain temperatures from 33° to 38°F, Freezers hold -8° to 0°F
- Down duct channel ensures even distribution of air flow throughout the cabinet
- 2-year parts & labor warranty, 5-year compressor part warranty, with option to purchase up to 5-year parts & labor warranty

REFRIGERATORS	DOORS	SHELVES	DIMENSIONS
MBF8010GR	2 Half	3	28¾" w x 31¼" d x 81¼" h
MBF8010GRL	2 Half, Left-Hinged	3	28¾" w x 31¼" d x 81¼" h
MBF8004GR	1 Full	3	28¾" w x 31¼" d x 81¼" h
MBF8005GR	2 Full	6	51" w x 31¼" d x 81¼" h
MBF8006GR	3 Full	9	77½" w x 31¼" d x 81¼" h
FREEZERS			
MBF8007GR	2 Half	3	28¾" w x 31¼" d x 81¼" h
MBF8007GRL	2 Half, Left-Hinged	3	28¾" w x 31¼" d x 81¼" h
MBF8001GR	1 Full	3	28¾" w x 31¼" d x 81¼" h
MBF8002GR	2 Full	6	51" w x 31¼" d x 81¼" h
MBF8003GR*	3 Full	9	77½" w x 31¼" d x 81¼" h

*not ENERGY STAR

Designed for consistent cooling.



Reach-Ins

- Top-mounted refrigeration
- Maintains consistent refrigeration from 33° to 40°F and freezer temperatures from -5° to 0°F
- Stainless steel front and sides with a Seamless Delrite® ABS interior liner
- Interior shelving accommodates full-size 18" x 26" sheet pans
- Self-closing doors feature a stay-open position at 120° to streamline loading and unloading
- 3-year parts and labor warranty, additional 4-year compressor parts warranty

REFRIGERATORS	DOORS	SHELVES	DIMENSIONS
6025XL-S	1 Solid	3	25½" w x 32¾" d x 79¾" h
6025XL-G	1 Glass	3	25½" w x 32¾" d x 80½" h
6051XL-S	2 Solid	6	51" w x 32¾" d x 79¾" h
6051XL-G	2 Glass	6	51" w x 32¾" d x 80½" h
FREEZERS			
6125XL-S	1 Solid	3	25" w x 32¾" d x 79¾" h
6151XL-S	2 Solid	6	51" w x 32¾" d x 79¾" h



6025XL-S

High-performance, top-mounted compressors



6051XL-G



REFRIGERATION



Cross Temp® Top Mount Freezer/Refrigerators



- Stainless steel exterior and aluminum interior
- Easily converts from refrigerator to freezer, -15° to 40°F
- Environmentally friendly R-290 refrigerant
- CT12-12HC-1HSD includes 2 refrigerated drawers
- 7-year warranty on parts, labor and compressor



	DOORS	SHELVES	DIMENSIONS
CT1HC-1S	1 Solid	3	26" w x 33 3/4" d x 78 1/2" h
CT2HC-1G	2 Glass	3	52" w x 33 3/4" d x 85" h
CT12-12HC-1HG	2 Half Glass	4	26 1/2" w x 34 1/4" d x 78 1/2" h
CT12-12HC-1HSD	1 Half Solid	2	26 1/2" w x 34 1/4" d x 78 1/2" h



CT1HC-1S



CT12-12HC-1HG

Multiple door styles available

Flexible cooling, reliable performance.



HFIHC-1HS

Horizon® Series Top Mount Refrigerators & Freezers

- Top-mounted refrigeration system
- Stainless steel front and corrosion-resistant aluminum interior
- Self-closing doors include a 120° stay-open feature
- Utilizes eco-friendly R-290 refrigerant
- 33 3/4" d x 78 1/2" h
- 7-year warranty on parts, labor, and compressor

REFRIGERATORS	WIDTH	DOORS	SHELVES
HR1HC-1S	26"	1 Solid	3
HR2HC-1G	52"	2 Glass	6
HR3HC-1S	78"	3 Solid	9
FREEZER			
HFIHC-1HS	26"	2 Half Solid	3



HR1HC-1G



STR Spec Series® Reach-Ins

- High-capacity, reach-in system
- Refrigerators hold a consistent 33° to 38°F
- Freezers maintain -10°F
- Stainless steel interior and exterior
- Solid swing, self-closing doors with a 120° stay-open position
- Other solid and glass door variations are available
- Factory installed interior kit options
- Top-mounted compressor and high-density insulation
- R-290 refrigerant
- LED interior lighting
- 33¾" d x 77¾" h
- 7-year labor, 7-year parts, 7-year compressor warranty

REFRIGERATORS	DOORS	SHELVES	WIDTH
STR1R-1S-HC	1	3	27½"
STR2R-2S-HC	2	6	52½"
STR3R-3S-HC*	3	9	77¾"

FREEZERS	DOORS	SHELVES	WIDTH
STR1F-1S-HC*	1	3	27½"
STR2F-2S-HC*	2	6	52½"
STR3F-3S-HC*	3	9	77¾"

*Not ENERGY STAR®
 **Height does not include 6¼" for casters or 6" for optional legs. Height does not include ¼" for system mechanical components.
 †Depth does not include ½" for door handle.



STR1R-1S-HC



STR2F-2S-HC

Self-closing doors with a 120° stay-open position

T-Series Reach-Ins

- Stainless steel doors and front
- Clear coated aluminum interior with stainless steel floor
- Entire cabinet structure and solid door are foamed-in-place using a high density, polyurethane insulation that has zero ozone depletion potential (ODP) and zero global warming potential (GWP)
- Refrigerators hold 33° to 38°F, freezers hold -10°F
- Adjustable, heavy-duty PVC coated wire shelves
- Exterior temperature display
- 4" casters standard, legs available
- 29½" d x 78¾" h
- 7-year labor, 7-year parts, 7-year compressor warranty

REFRIGERATORS	DOORS	SHELVES	WIDTH
T-23-HC†*	1	3	27"
T-49-HC*	2	6	54½"
T-72-HC	3	9	78½"

FREEZERS	DOORS	SHELVES	WIDTH
T-23F-HC†*	1	3	27"
T-49F-HC*	2	6	54½"
T-72F-HC	3	9	78½"

†CE *ENERGY STAR®
 **Height does not include 5" for casters or 6" for optional legs.



T-49-HC

Reliable cooling, eco-smart insulation.



Reach-Ins

- Stainless steel front
- Smooth, polished chrome workflow door handles
- Aluminum end panels and interior
- LED interior lighting
- 3" non-CFC polyurethane foam insulation
- R-290 refrigerant
- 5" casters
- 35 $\frac{3}{4}$ "d x 82 $\frac{1}{4}$ "h
- Made in USA
- 7-year warranty on parts, labor, and compressor



REFRIGERATORS	DOORS	SHELVES	WIDTH
1RN	1	3	26"
2RN	2	6	52"
3RN	3	9	78"
FREEZERS			
1FN	1	3	26"
2FN	2	6	52"
3FN	3	9	78"

UltraSpec™ Sliding Glass Door Display Refrigerator

- Stainless steel exterior and interior
- Sliding glass door on top, solid swing door on bottom
- Interior LED lighting
- 6 wire shelves
- R-290 refrigerant
- 7-year parts and labor warranty, 2-year warranty on magnetic door gaskets, lifetime warranty on handles and hinges (parts only)

DRS-2D-SI-HD-HC 52 $\frac{1}{2}$ "w x 33 $\frac{1}{2}$ "d x 84 $\frac{1}{4}$ "h



RFS-2D-SI-HC



UltraSpec™ Dual Temp Reach-Ins

- 2-section units feature solid swing doors with 6 shelves
- Combines refrigeration (right) and a warming or freezer cabinet (left)
- Heavy-duty stainless steel construction
- Dual electronic controls with manager lockout
- R-290 refrigerant
- 34 $\frac{1}{2}$ "d x 84 $\frac{1}{4}$ "h
- 7-year parts and labor warranty, 2-year warranty on magnetic door gaskets, lifetime warranty on handles and hinges (parts only)

HRS-2D-SI-EW-HC Refrigerator-Warmer, 58 $\frac{3}{4}$ "w
RFS-2D-SI-HC Refrigerator-Freezer, 52 $\frac{1}{2}$ "w

Performance that keeps its cool.

UltraSpec™ Refrigerators & Freezer

- Stainless steel exterior and interior
- Electronic control system
- R-290 refrigerant
- Stay-open doors
- 7-year parts, labor and compressor warranty and a 2-year warranty on magnetic door gaskets, lifetime warranty on handles and hinges (parts only)



REFRIGERATOR	DOORS	SHELVES	DIMENSIONS
RS-2D-SI-HG-HC	4 Half Glass	6	52 $\frac{1}{2}$ "w x 33 $\frac{1}{2}$ "d x 84 $\frac{1}{4}$ " h
FREEZER			
FS-1D-SI-HC*	1 Full Solid	3	26 $\frac{1}{2}$ "w x 34 $\frac{1}{2}$ "d x 84 $\frac{1}{4}$ "h
ROLL-THRU			
RIS-1D-SI-PT-HC	2 Full Solid	—	36 $\frac{1}{2}$ "w x 40 $\frac{1}{4}$ "d x 82 $\frac{1}{2}$ "h
PASS-THRU			
RSA-3D-SI-PT-G-HC	6 Full Glass	9	77 $\frac{1}{4}$ "w x 35 $\frac{1}{4}$ " x 84 $\frac{1}{4}$ "h

*Not ENERGY STAR®



RS-2D-SI-HG-HC



RIS-1D-SI-PT-HC

M3 Series Reach-Ins

- Stainless steel exterior, aluminum interior with stainless steel floor
- Environmentally-friendly R-290 refrigerant
- Pressure-relief doors allow easy, instant door opening
- Adjustable, heavy-duty, polyethylene-coated wire shelves
- Self-cleaning condenser automatically cleans condenser daily
- 30 $\frac{3}{4}$ "d x 77 $\frac{3}{8}$ "h
- 5-year parts and labor warranty, 7-year compressor warranty



REFRIGERATORS	WIDTH	DOORS	SHELVES
M3R24-1-N	28 $\frac{3}{4}$ "	1	3
M3R47-2-N	51 $\frac{1}{4}$ "	2	6
FREEZER			
M3F47-2-N	51 $\frac{1}{4}$ "	2	6

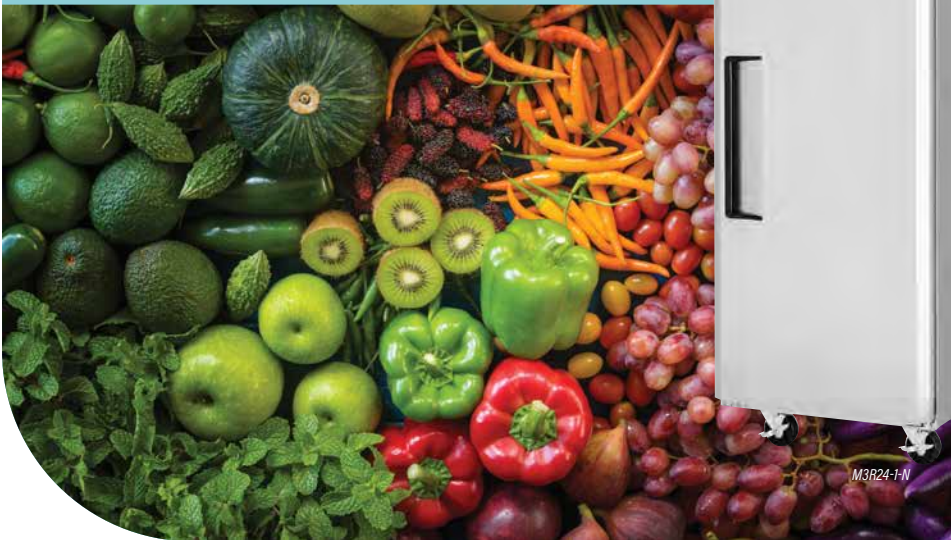

M3R47-2-N

Self-cleaning condenser system



Super Deluxe Reach-Ins

- Bottom mount compressor
- Stainless steel exterior (galvanized steel top, bottom and back)
- Stainless steel interior and shelves
- Self cleaning condenser system standard
- Digital monitoring system, rapid cool-down function (Turbo Cooling & Freeze)
- Hassle free warranty
- 54 $\frac{1}{2}$ "w x 30 $\frac{3}{4}$ "d x 78 $\frac{1}{4}$ "h
- 5-year parts and labor warranty, 7-year compressor warranty

TSR-49SD-N6 Refrigerator, 2 Doors, 6 Shelves
TSF-49SD-N Freezer, 2 Doors, 6 Shelves



TSR-49SD-N6

Digital monitoring system with rapid Turbo cooling





Slim Line Reach-Ins

- Maximizes storage in tight spaces
- Stainless steel exterior, aluminum interior, and side panels
- Environmentally friendly R-290 refrigerant
- Bright, cool LED interior lighting
- Heavy-duty epoxy-coated steel shelves
- Self-closing, solid swing doors with magnetic snap-in gaskets
- 5" casters
- Made in USA
- 17 $\frac{3}{4}$ "w x 35 $\frac{3}{4}$ "d x 82 $\frac{1}{4}$ "h
- 7-year warranty on parts, labor, and compressor



REFRIGERATORS	DOORS	SHELVS
1RSEN	1 Full	5
1RSENHD	2 Half	5
FREEZERS		
1FSEN	1 Full	5
1FSENHD	2 Half	5



FASTCOOLER

Fastcooler is U.S. Cooler®'s Quick Ship Program with in-stock models usually shipping within 3-5 days. Fastcooler models are made with the same precision and high-quality materials, but are designed to provide a quick delivery at a low cost.



- Panels are UL and NSF approved
- EISA compliant
- Floor or floorless options (all freezers come with a floor)
- Indoor and outdoor options (outdoor models available with vinyl rainroof)
- Vert-Ergo™ key lock handle, adjustable spring-loaded hinges, LED vapor-proof light/digital thermometer
- Doors are 34" x 76", self-closing, left or right hinge (to be specified)
- Available with remote pre-assembled, saddle mount, or self-contained refrigeration
- Numerous lengths & widths, even models shipped within a day
- Multiple door placement locations
- 10-year panel warranty
- 1-year compressor labor warranty
- 1-year parts warranty
- 5-year compressor warranty

COUNTLESS, COST-EFFECTIVE SOLUTIONS

U.S. COOLER® CUSTOM WALK-INS

U.S. Cooler® was built around the ability to manufacture custom-sized walk-in coolers and freezers. Our unique automated process allows panels to be manufactured to configure to any size walk-in cooler or freezer at the same cost and production time as standard sizes. As a leader in the industry, U.S. Cooler® will manufacture your walk-in to your exact design and specifications.

- 4" extruded polystyrene or 4" foamed-in-place polyurethane
- 26 ga. galvalume, 26 ga. painted, or 22 ga. stucco stainless steel
- Self-closing doors, adjustable spring-loaded hinges, flush mount with magnetic gasket, chrome latches and hinges, Vert-Ergo™ handle, safety release handle, automatic self-closer, and a LED vapor-proof light/digital thermometer included
- 22 ga. stainless steel floors
- All sizes, remote, side mount, top mount, indoor, outdoor
- Panels are UL and NSF approved
- EISA compliant



A PRODUCT OF CRAIG INDUSTRIES, INC.



Design your walk-in cooler or freezer to fit any space



NORLAKE[®]

14,000+

CONFIGURATIONS SHIP IN 2 DAYS



Experience the future of cold storage with Norlake **Kold Locker[®]** walk-ins.

Norlake walk-ins are **THE industry standard**.

Our **groundbreaking design** features patented Capsule Pak ECO™ refrigeration, utilizing **eco-friendly R290 refrigerant** for a **greener, more cost-effective solution**.

Kold Locker[®] walk-ins **ship in just two days** and are **easily installed on-site** for a **complete package solution**.

Don't settle for less when you can **have the best**. Choose **Kold Locker[®]** and elevate your cold storage.



Capsule Pak ECO™: Industry Leading Energy Efficiency



The Best, Most Energy Efficient Panel Construction & Insulation



The Best Standard Warranty in the Industry



Nationwide Installation & Service Program



RSG
Refrigerated Solutions Group[®]

REFRIGERATION

Polar-Pak Walk-Ins feature top-mount, self-contained Refrigeration.



KOLPAK®

POLAR-PAK & KOLDFRONT WALK-INS

Models available in 5 business days - free freight.
Free LTL Freight on published AutoQuotes models, \$150 Liftgate applies when requested.

- Coolers & freezers
- Era floor or floorless (4" Screed)
- Available in 7' & 8' heights
- Backed by Kolpak's 1-year parts & labor warranty

KoldFront Walk-Ins feature Precharged (PC) Remote Refrigeration.



BOLTOVER DOOR SECTION

The boltover replacement door section bolts directly to an existing door frame for a simple install. New frame, plug & hardware.

- Standard 26 Ga. Galvalume finish
- Brushed hardware
- Locking handle with inside release
- Two spring-loaded, field-adjustable, cam-lift hinges
- Hydraulic door closer
- 2" dial thermometer
- Switch with pilot light



KOLPAK®

CUSTOM WALK-INS

Our walk-ins are designed to meet your specifications and configurations, catering to both large and small needs with our wide selection of custom options.



WALK-INS COME STANDARD WITH ...

- Steel-reinforced door frame construction designed for maximum strength and impact-resistant FRP door perimeter
- Spring-loaded, field-adjustable cam-lift hinges. Brushed finish used for standard door packages, also available in polished or stainless steel
- Kolpak Era floors are designed to withstand foot or cart traffic and loads approved up to 1,000 lbs. psf uniform load without the need for plywood
- Pre-Charged (PC) units are charged with a refrigerant charge sufficient for up to a 50' line run and designed with an oversized receiver tank and condenser surface, saving money on installation and cost of operation
- Backed by Kolpak's 1-year parts & labor warranty

KOLPAK AIR SHIELD

Up to 20% more energy efficient than strip curtains & sanitation solutions.
Keeps the cool air where it belongs and eliminates the hassles of strip curtains. Designed to significantly reduce the amount of warm air infiltration into the refrigerated space.

- An innovative air delivery system that channels a barrier of refrigerated air across the door opening
- Mounts vertically adjacent to the walk-in door on the interior wall surface
- Automatically activated when the door is opened and shuts off when the door closes
- Available for coolers & freezers, NSF and UL Certified
- New or existing walk-ins, even if it's not a Kolpak



A hands-free refrigerated air barrier that is activated when the door is opened to keep your path clear.



Convenience Store Coolers

- When it comes to reach-in and glass door coolers and freezers for convenience stores, Amerikooler has personalized customization, finishes, placement, and performance
- Personalize your cooler with; sliding doors, view ports, strip/air curtains, remote control and monitoring units, and even a natural air purifier
- Convenience Kool is a comprehensive solution catered to your needs, all backed by the highest quality and service of Amerikooler

Personalize your cooling solution.



Popular Walk-In Cooler and Freezer sizes available. Standard Sizes:

- 6' x 6'; 6' x 8'; 6' x 10'; 6' x 12'
- 8' x 8'; 8' x 10'; 8' x 12'
- 10' x 10'; 10' x 12'



AK Series 3 Quick-Ship Walk-Ins

- Crafted with only the highest quality materials, deluxe AK-XPS Grey insulation, and backed by Dupont's 50-Year Thermal Warranty, these models are a quick, convenient, and cost-effective walk-in option for any business
- Available models are indoor remote and/or self-contained coolers and freezers in pre-specified sizes
- Choice of single 30" or 36" centered clear door opening on any side
- Smooth aluminum interior floor rated at 700 lb per sq ft of uniformly distributed load
- Floor-less walk-ins are supplied with NSF vinyl screed
- Temperature regulating thermostat heater
- Digital LED thermometer with pilot light switch

Amerikooler beats the competition when you need cool, fast!

Crafted with only the highest quality materials, the best insulation, and a 50-Year Thermal Warranty backed by Dupont, Amerikooler is a brand you can rely on.



AK Combo Kool Walk-Ins

- The ultimate solution for your customized cooler and freezer needs
- Designed to fit any shape or size with two or more compartments; side-by-side, nested, split configurations, sectioned spaces, or any other combination
- Multiple access points and precision temperature control, makes storing and retrieving products a breeze
- Elevate your cold storage capabilities with AK Combo Kool Walk-Ins



Custom Kool Walk-Ins

- Ranges from standard 6' x6' units to custom warehouses
- Provides top-of-the-line panels designed for maximum durability and efficiency
- Partners with the leading refrigeration equipment providers for the best cooling systems available

Optional Features

- Digital LED thermometers/light switches
- High-security, heavy-duty deadbolt handle latch
- Heavy-duty top performer hinges
- Interior safety release latches & pull handles
- Windows on door or wall
- Kick plates, bumper rails, and much more





The Walk-In of Choice

Backed by decades of proven expertise, ThermalRite® provides reliable walk-in cold storage solutions for commercial, non-commercial, and industrial environments. Known for quality and innovation, our systems are built to meet the demands of foodservice, catering, warehousing, and more.

- Custom-built to your exact dimensions
- Modular design for flexible layouts
- Suitable for indoor and outdoor use
- Available as coolers, freezers, or combination units

The Easy Button

ICS® one-piece walk-ins provide efficient, durable cold storage designed to reduce costs, save space, and simplify installation—ideal for outdoor applications.

- Lower construction costs by moving units outdoors
- Free up indoor space for seating, kitchen expansion, or operations
- One-piece design with continuous foam-in-place insulation for reliable temperature control
- Factory-installed refrigeration and electrical components
- Quick setup—operational in as little as 2-4 hours



Additional finishes are available along with a wide range of paint color options for ICS® & ThermalRite®.



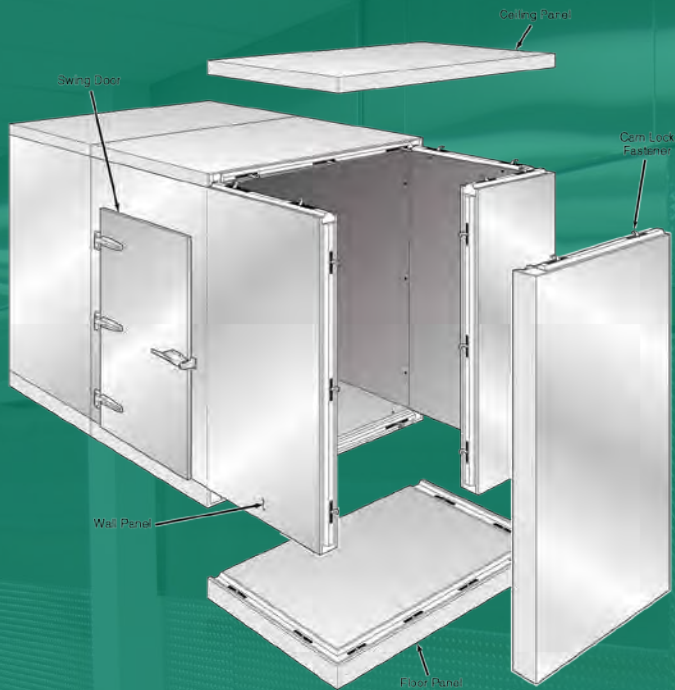

- **Over 100 years of manufacturing high quality polyurethane foamed-in-place panels for walk-in coolers and freezers**
- **Employee-owned and manufactured in the United States**
- **5 factories across the country providing the best freight costs, no matter where the project is located**
- **Dedicated sales and service support from start to finish**
- **Customized, designed to your exact specifications**
- **Panels meet all 2009 Federal Energy requirements, 2020 DOE, and new regulations for foam and refrigeration**
- **Replacement floors and doors available for both walk-in coolers and freezers**
- **15-year panel and floor warranty, 5-year door warranty**

Bally®

REFRIGERATED BOXES, INC. IS

A2L READY!

The Next Generation of Refrigeration Equipment



**Outdoor
Condensing Unit**

SMARTVAP I
INTUITIVE EVAPORATOR CONTROL TECHNOLOGY



Our factory-installed leak detection and mitigation strategy incorporates the safety mechanisms required for A2L refrigerants. This new generation of low GWP equipment...will be easy for today's technicians to service. Our A2L equipment is designed for R454A, R454C & R455A refrigerants.

Bally systems meet the January 1, 2026 requirement that all new commercial refrigeration products use a refrigerant <300 GWP (R-454A) for systems under 200 lb and <150 GWP (R-454C & R-455A) for systems above 200 lb.

Bally Refrigerated Boxes is recognized internationally as a premier manufacturer of Walk-in Coolers and Freezers and Refrigerated Buildings for the food service industry.



Drive-Thru Commercial Air Curtain



- Compact, simple to mount and easy to operate
- For mounting heights up to 3'
- Clear satin anodized aluminum exterior cabinet
- Factory installed "mount anywhere" bracket system
- 3 prong power cord, 6'
- UL Listed for outdoor use
- Made in USA
- 5-year limited warranty

DTU03 7 $\frac{1}{2}$ "d x 7"h



Sanitation Certified Air Curtains

- Block flying insects at entryways up to 7' high
- EPH Listed to ANSI/NSF-37 to meet health codes (SHD07)
- Low profile design for tight clearances (SLC07)
- White or black powder-coated aluminum, stainless steel and custom colors available
- UL Listed for outdoor use
- Made in USA
- 5-year limited warranty

SLC07 8"d x 8 $\frac{1}{2}$ "h, $\frac{1}{8}$ hp
 SHD07 15"d x 14"h, $\frac{3}{4}$ hp, (2) $\frac{3}{4}$ hp, or (3) $\frac{3}{4}$ hp



Commercial Low Profile Ambient Air Curtains



- Maintain indoor temperatures and deter flying insects
- For mounting heights up to 8' and insect control up to 7'
- Low-profile design fits tight overhead spaces
- Cuts energy costs for walk-in coolers and main entrances
- Available in white or black powder coated finish, stainless steel and custom colors available
- Made in USA
- 5-year limited warranty

CLC08 13 $\frac{1}{2}$ "d x 8 $\frac{1}{2}$ "h, $\frac{1}{8}$ hp



Pass-Thru Ambient Air Curtain

- Maintains sanitation at pass-thru and concession windows
- Recommended for windows up to 6" high
- Variable speed motor creates a powerful air barrier
- Available in white or black powder coated finish, stainless steel and custom colors available
- Made in USA
- 5-year limited warranty

PE06 8 $\frac{1}{2}$ "d x 8 $\frac{1}{2}$ "h, $\frac{1}{8}$ hp



HURriCHill™ Compact Blast Chiller/Shock Freezers



- Environmentally friendly R-290 refrigeration system
- New advanced touch controls
- Polished stainless steel construction
- Chilling: lowers food temperatures from 160° to 38°F within 105 minutes
- Freezing: lowers food temperatures from 160° to 0°F within 4 hours
- Holds 12" x 20" x 2½" pans
- AP5BCF45-2-P comes standard with 2½" casters
- 3-year parts and labor warranty

AP3BCF30-1-P Holds 3 pans, 30 lb Chill Capacity, 18 lb Freeze Capacity, 25½" w x 25½" d x 36" h
AP5BCF45-2-P Holds 5 pans, 50 lb Chill Capacity, 30 lb Freeze Capacity, 29½" w x 28½" d x 37½" h



AP3BCF30-1-P

AP5BCF45-2-P

CFC-free polyurethane insulation



AP12BCF150-2-P



AP20BCF200-3-P



HurriChill™ Undercounter Blast Chiller and Shock Freezer



- Constructed of polished stainless steel
- Environmentally friendly R-290 refrigeration system
- Chilling (soft or hard) lowers the food core temperature from 160° to 38°F within 105 minutes
- Freezing (hard) lowers the food core temperature from 160° to 0°F within 4 hours
- Easy to use and read solid state electronic control panel
- Evaporator temperature range is 25° to -40°F
- 3-year parts and labor warranty

- Holds (14) 12" x 20" x 2½" pans or (7) 18" x 26" pans (sold separately)
- Chills 70 lb from 160° to 38°F in 90 minutes
- Stainless steel work top
- 7" LCD touch screen
- Stainless steel interior and exterior
- 3-year parts and labor warranty



AP12BCF150-2-P Holds (12) 18" x 26" Pans, 150 lb Chill Capacity, 150 lb Freeze Capacity, 32¾" w x 41¾" d x 75" h
AP20BCF200-3-P Holds 1 Mobile Rack, 200 lb Chill Capacity, 120 lb Freeze Capacity, 47¾" w x 42" d x 94¾" h

AP7BCF70-2-C-P 59" w x 33¾" d x 44" h



BCB 05US



BCB 10US220



Blast Chillers

- Fitted with an intuitive and user-friendly electronic control panel that allows chilling cycles to be set rapidly
- Incorporated condensing unit
- Either soft/hard chilling or freezing
- Automatic defrost system
- Holds 18" x 26" pans
- Uses R-290 refrigerant
- Chilling capacity in 90 minutes from 197° to 37°F
- Freezing capacity in 240 minutes from 197° to 0°F
- 1-year parts & labor warranty

BCB 05USN Holds 5 Pans, 57 lb Chill Capacity, 35 lb Freeze Capacity, 34¾" w x 34" d x 37¾" h

BCB 10USN Holds 10 Pans, 75 lb Chill Capacity, 48.5 lb Freeze Capacity, 34" w x 34" d x 61½" h



Touch screen display with automatic cooling cycle

Reach-In Blast Chiller

- Capacity for (18) hotel pans or (9) sheet pans
- Self-contained refrigeration system with automatic condensate evaporator
- Stainless steel exterior, sides, top, interior, and universal pan slides
- 6" casters provide mobility
- Color coded probe identification
- 1 solid swing door with self-closing door hinge with 90° positive open stop



BC-918RI 135° to 40°F in 240 min or less, 40" w x 35¾" d x 71" h



VICTORY

Merchandise Refrigerators

- Full-height beveled glass doors and stainless steel exterior
- Electronic controls
- Interior LED lighting
- Bottom-mounted compressor
- 34¾" d x 84" h
- 7-year parts, labor & compressor warranty

LSR23HC-1 1 Door, 5 Shelves, 27¼" w
LSR72HC-1 3 Doors, 15 Shelves, 76" w



LSR72HC-1

LSR23HC-1

Sleek, durable stainless steel.

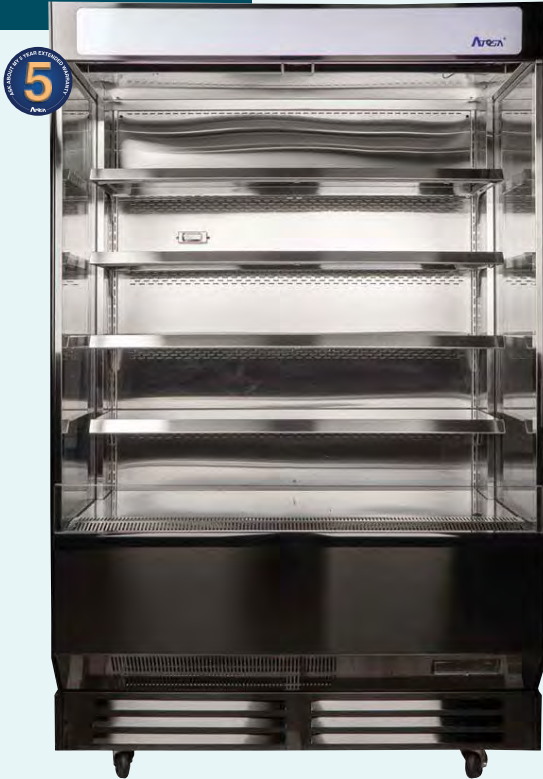

AOM-50B



Open Air Merchandisers

- Encourages impulse sales with an open-front design
- LED lit header panel, interior top, and lighting on each shelf
- Full Electronic Controller
- Black exterior & stainless steel interior
- Integrated night curtain conserves energy and protects inventory overnight
- 4 pre-installed stainless steel shelves
- Pre-installed 4" casters
- 28"d x 83"h
- Maintains food safe temperatures from 33° to 38°F
- 2-year parts & labor warranty, 5-year compressor part warranty, with option to purchase up to 5-year parts & labor warranty

AOM-40B 39½"w
AOM-50B 51½"w



Glass Door Merchandisers

- Black steel exterior with stainless steel interior
- Lighted header panel
- LED interior lighting
- Full Electronic Controller
- Double pane glass swing or sliding door(s)
- Self-closing door(s) with automatic stay open feature
- Recessed door handle
- Magnetic door gasket
- Environmentally friendly R-290 refrigerant
- 2" casters
- Bottom mount compressor
- Refrigerators hold 35° to 38°F, Freezers maintain -8° to 0°F
- 2-year parts & labor warranty, 5-year compressor part warranty, with option to purchase up to 5-year parts & labor warranty

REFRIGERATORS	DOORS	SHELVES	DIMENSIONS
MCF8726GR	1	4	24½" w x 24" d x 63½" h
MCF8725GR	1	4	24½" w x 24" d x 76½" h
MCF8722GR†	1	4	27" w x 31½" d x 81½" h
MCF8733GR	2	8	39½" w x 31½" d x 81½" h
MCF8727GR*	2	8	54½" w x 29" d x 81½" h
MCF8723GR†	2	8	54½" w x 31½" d x 81½" h
MCF8724GR	3	12	81" w x 31½" d x 81½" h
FREEZERS			
MCF8720GR	1	4	27" w x 31½" d x 81½" h
MCF8732GR	2	8	39½" w x 31½" d x 81½" h
MCF8721ES†	2	8	54½" w x 31½" d x 81½" h
MCF8728GR	3	12	81" w x 31½" d x 81½" h

*Sliding Doors
†ENERGY STAR®



MCF8724GR



No-stoop bottom shelf



MCF8726GR

Keeps items chilled and ready.



GDM-69-HC-LD



Glass Door Merchandisers

- Natural R-290 refrigerant
- Holds 33° to 38°F
- No stoop bottom shelf
- PVC coated wire shelves
- Black powder coated exterior, with aluminum interior and a stainless steel floor
- Double pane thermal insulated glass
- Self-contained system, no plumbing required
- Bottom mount heavy-duty compressor
- Standard in Black - optional exterior in White or Stainless Steel
- Various sizes and options are available
- 7-year labor, 7-year parts, 7-year compressor warranty

SWINGING DOORS	DOORS	SHELVES	DIMENSIONS
GDM-10-HC~TSL01	1	3	24 $\frac{1}{2}$ "w x 22 $\frac{1}{2}$ "d x 53 $\frac{3}{4}$ "h
GDM-12-HC~TSL01	1	3	24 $\frac{1}{2}$ "w x 22 $\frac{1}{2}$ "d x 62 $\frac{3}{4}$ "h
GDM-23-HC~TSL01†	1	4	27" w x 29 $\frac{1}{2}$ " d x 78 $\frac{1}{2}$ " h
GDM-49-HC~TSL01	2	8	54 $\frac{1}{2}$ " w x 29 $\frac{1}{2}$ " d x 78 $\frac{1}{2}$ " h
GDM-72-HC~TSL01	3	12	78 $\frac{1}{2}$ " w x 29 $\frac{1}{2}$ " d x 78 $\frac{1}{2}$ " h

SLIDING DOORS	DOORS	SHELVES	DIMENSIONS
GDM-47-HC-LD	2	8	54 $\frac{1}{2}$ " w x 29 $\frac{1}{2}$ " d x 78 $\frac{1}{2}$ " h
GDM-69-HC-LD	3	12	78 $\frac{1}{2}$ " w x 29 $\frac{1}{2}$ " d x 78 $\frac{1}{2}$ " h

† CE



GDM-49-HC-TSL01



GDM-47-HC-LD



GDM-23-HC-TSL01

Self-closing, glass swing or sliding doors



MarketMax™ Glass Door Merchandisers

- Illuminates chilled beverages and grab-and-go items
- Low-E argon-filled glass doors offer a clear view of products
- Black coated steel exterior and white coated steel interior
- Energy-efficient R-290 refrigerant
- Maintains a consistent 36° - 38°F
- Self-closing door with 120° stay-open feature
- Self-contained bottom mount refrigeration system
- 7-year parts and labor warranty, 7-year compressor warranty

	DOORS	SHELVES	DIMENSIONS
MMR27HC-1-B	1	5	30" w x 33½" d x 78½" h
MMR49HC-1-B	2	10	52" w x 33½" d x 78" h
MMR72HC-1-B	3	15	75" w x 33½" d x 78½" h



Bright and efficient beverage display.



CVM Contemporary Visual Merchandisers

- Curved-edge, single glass swing door
- Built-in handle for opening from the top or side
- Self-cleaning condenser technology
- Exterior - non peel or chip black powder coated cold rolled steel; durable and permanent
- Interior - attractive, black aluminum interior liner with stainless steel floor
- R-290 hydrocarbon refrigerant
- Adjustable wire shelving holds 20 oz bottles
- Maintains temperatures from 33° to 38°F
- Leg Levelers and (4) 2½" integrated rollers
- 7-year labor warranty, 7-year parts warranty, 7-year compressor warranty

	SHELVES	DIMENSIONS
CVM-11-HC~EGC01	4	24¼" w x 22" d x 53½" h
CVM-13-HC~EGC01	5	24¼" w x 22" d x 63½" h
CVM-20-HC~EGC01	6	27" w x 24½" d x 78½" h
CVM-24-HC~EGC01	6	27" w x 29½" d x 78½" h
CVM-27-HC~EGC01	6	30" w x 29½" d x 78½" h

*Depth does not include ¼" for rear mechanical components.



Energy-efficient LED interior lighting

CVM-27-HC~EGC01



Countertop Ice Cream Merchiser

- Compact design freezes and showcases ice cream treats
- Maintains -15° to -10°F
- Stainless steel front, sides, top, door and grille (galvanized steel back & bottom)
- Interior liner is made of corrosion resistant aluminum
- Stay-open door 120° feature simplifies high-volume loading



UCF20HC-25-15 1 Glass Door, 2 Shelves, 20" w x 25" d x 25" h



Easily showcase frozen products.



Breeze™ Open-Air Merchiser

- Gravity-Flo organizers keep beverages front-facing
- Bright white interior, lighting showcases contents
- Black powder coated steel exterior
- Maintains safe temperatures from 32° to 40°F
- Epoxy coated shelves
- R-290 refrigerant
- 3-year parts and labor warranty, 5-year compressor warranty

BZ13HC-B 3 Shelves, 30" w x 32¾" d x 54¾" h



Dairy Curved End Open Merchisers

- Open air merchisers with a multi-level design, perfect for grab-and-go food and drinks
- Maintains consistent 36° to 40°F
- Self-contained refrigeration system
- Creates long, continuous refrigerated displays
- Integrated full-length LED lighting illuminates products on multiple display tiers
- Copeland hermetic compressor with electronic controls
- Black steel frame with eco-friendly insulation
- 1-year parts and labor warranty, 5-year compressor warranty

SC-OD40E-6S-B 2 Shelves, 39" w x 40" d x 53" h
 SC-OD30E-3S-B-SW 1 Door, 3 Shelves, 39" w x 33½" d x 72" h



SC-OD40E-6S-B

SC-OD30E-3S-B-SW

Endless lineup capabilities

Foamed-in-place insulation



Red Meat Service Case

- Single-duty case designed for merchandising red meat
- Full length gravity coil system with extra full-length humidity coil at the main deck
- Holds temperature between 34° to 36°F
- Stainless steel top, white exterior & interior
- Endless design with removable end panels
- Rear double-pane glass doors
- 1-year parts and labor warranty, 5-year compressor warranty

SC-CMS40E-10-LED 124½" w x 40" d x 53" h



REFRIGERATION



Howard McCray

Glass Door Merchandiser Freezer

- 4 section merchandiser offers 102 cu ft of storage
- Hinged glass doors and end panels
- Each section comes with 4 heavy duty epoxy coated shelves
- Foamed-in-place insulation maintains consistent -5° to 5°F temperatures
- Bottom-mount dual compressors
- Bright white interior and exterior create a clean display
- Designed to operate in an environment of 75° and 55% relative humidity
- Electronically controlled with audio alarm
- 1-year parts and labor warranty, 5-year compressor warranty

GF102BM-FF 103¾" w x 35½" d x 82¼" h



Maximize product visibility.

Howard McCray

Packaged Meats Low-Base Open Merchandiser

- Open-air case for grab-and-go packaged meats
- 4 rows of illuminated shelves with product stop and LED lighting on multiple tiers
- Remote refrigeration reduces in-store heat and noise
- Maintains safe product temperatures from 36° to 40°F, includes air screen
- Black exterior and interior for a professional presentation
- 16" straight plexi end panels
- Foamed-in-place insulation
- 1-year parts and labor warranty, 5-year compressor warranty

R-0M35E-6-LB-B

75" w x 34½" d x 78½" h



Structural Concepts

DELIVERING FRESH. ALWAYS.™

Fusion Self-Service Refrigerated Merchandisers

- High-capacity, open-front design
- Breeze self-contained R-290 refrigeration maintains food-safe temperatures of 40°F or less
- Brilliant LED illumination at the top and on each shelf
- Black powder coated exterior with a stainless steel rear exterior
- Includes casters with levelers
- 5 solid shelves
- 37½" d x 85½" h
- 2-year parts and labor warranty, 5-year compressor warranty

MD485R
MD685R

50¼" w
74¼" w



Structural Concepts®
DELIVERING FRESH. ALWAYS.™

Oasis Refrigerated Self-Service Undercounter Cases

- Free-standing merchandiser that's perfect for displaying cold beverages
- Undercounter air curtain design
- Integrated LED top lighting and mirrored end panels
- Bottom-mounted R-290 refrigeration
- E-coated evaporator coil
- 32¼" d x 32¼" h
- 1-year parts and labor warranty, 5-year compressor warranty

Mirrored interior sides



C33R-UC

- C33R-UC** 35% w
- C43R-UC** 47% w
- C53R-UC** 59% w
- C63R-UC** 71% w



Structural Concepts®
DELIVERING FRESH. ALWAYS.™

Oasis Refrigerated Self-Service Cases

- Grab and go convenience in an attractive cabinet that complements any decor
- Open-front air curtain design keeps products chilled and accessible
- Integrated LED top light and mirrored interior panels
- Four adjustable metal shelves
- Slide-out, bottom-mounted refrigeration system
- 1-year parts and labor, 5-year compressor warranty



B37R

- BN37R** 35% w x 26¼" d x 82¼" h
- BN47R** 47% w x 26¼" d x 82¼" h
- BN57R** 59% w x 26¼" d x 82¼" h
- B37R** 35% w x 34¼" d x 82¼" h
- B47R** 47% w x 34¼" d x 82¼" h
- B57R** 59% w x 34¼" d x 82¼" h
- B67R** 71% w x 34¼" d x 82¼" h



Structural Concepts®
DELIVERING FRESH. ALWAYS.™

Refrigerated Autonomous Retail Merchandiser

- 1 glass swinging door w/ left hinge (self-closing) with 5 adjustable shelves
- Each shelf features 4 trays and LED lighting
- Breeze-E (Type-II) self-contained refrigeration maintains a consistent, food-safe temperature of 40°F or less
- Black powder-coated finish for a professional appearance
- R-290 refrigerant
- 1-year parts & labor warranty, 5-year compressor warranty

BD3632IS 45% w x 32¼" d x 82% h



Put your products in the spotlight.

REFRIGERATION



Vision Series Square End Self-Serve Display Cases

- Black powder-coated steel base and stainless steel deck
- LED top lighting illuminates contents
- 4 adjustable metal shelves can be positioned flat or slanted at 10° to customize displays
- Energy-saving night curtain reduces operational costs during off-hours
- R-290 refrigerant
- Also available with curved ends
- 1-year parts and labor warranty, 2nd through 5th year part only service compressor

VRSS3678S	36" w x 33" d x 78" h
VRSS4878S	47 3/4" w x 33" d x 78" h
VRSS6078S	59 1/4" w x 33" d x 78" h
VRSS7278S	71 1/4" w x 33" d x 78" h



Clear glass shelf and fixed vertical glass

Reveal® Refrigerated Self-Service Case

- Frameless glass construction provides easy grab-and-go merchandising
- Breeze~E (Type-II) self-contained R-290 refrigerant maintains product temperatures of 40°F or below
- Bright LED lighting on top and under each shelf
- One-piece molded ABS plastic tub
- 1-year parts and labor, 5-year compressor warranty

NR3651RRSSV	35 3/4" w x 33" d x 51" h
NR4851RRSSV	47 3/4" w x 33" d x 51" h
NR6051RRSSV	59 3/4" w x 33" d x 51" h
NR7251RRSSV	71 3/4" w x 33" d x 51" h
NR3658RRSSV	35 3/4" w x 33" d x 57 3/4" h
NR4858RRSSV	47 3/4" w x 33" d x 57 3/4" h
NR6058RRSSV	59 3/4" w x 33" d x 57 3/4" h

Structural Concepts®
DELIVERING FRESH. ALWAYS.™



Refrigerated Self-Service Island & End Cap Merchandisers

- Open-air, multi-sided merchandiser
- Breeze self-contained refrigeration with R-290 refrigeration
- Holds product temperatures at 40°F or less
- LED top lighting
- 3 metal shelves and removable deck pans
- Casters w/ levelers
- 208-240V
- 1-year parts & labor warranty, 5-year compressor warranty

ISLANDS	
FSI660R	80 3/4" w x 48 3/4" d x 60 3/4" h
FSI860R	99 3/4" w x 48 3/4" d x 60 3/4" h

END CAPS	
FSE460R	50 3/4" w x 36 3/4" d x 60 3/4" h
FSE660R	73 3/8" w x 50 3/4" d x 60 3/4" h



Easy access from all sides





The Signature of Quality™

Tempered glass squared shelves

Vision Series Slim-Line Display Cases

- Maintains consistent 38° to 40°F temperatures for chilled grab-and-go items
- 4 tiers of adjustable shelves install flat or slanted at 10°
- Standard energy-saving night curtain
- Black interior, frame, and shelves with a stainless steel display deck
- Smartphone-enabled controller for fast setup, monitoring, and maintenance
- R-290 refrigerant
- 24" d x 78" h
- 1-year parts and labor warranty, 2nd through 5th year part only service compressor



VRSL6078S

	SHELVES	WIDTH
VRSL3678S	4	36"
VRSL4878S	4	47 ¹ / ₄ "
VRSL6078S	4	59 ¹ / ₄ "
VRSL7278S	4	71 ¹ / ₄ "



Holds 12 milk crates

Refrigerated Self-Serve Milk Merchandiser

- Holds 12 milk crates
- Slanted stainless steel deck
- Electronic controls maintain a safe 35° to 38°F range
- Features a front-access catch pan and an energy-saving night curtain
- Choice of standard exterior laminates
- Recessed casters
- 1 adjustable white metal shelf with LED light and price tag molding
- Shelf can be flat or slanted downward at 10°
- Black metal front kick plate and trim with galvanized steel back
- White interior



The Signature of Quality™

LMDM4878SC 49¹/₁₆" w x 40¹/₁₆" d x 78" h



The Signature of Quality™

Vision Series - Flex™ 3-in-1 Multifunctional Merchandisers

- Maximize space and expand menu offerings with the flexibility to switch between heated, refrigerated or ambient temperatures
- Black powder-coated exterior
- Stainless steel interior, including shelves
- Tempered glass square ends, also available with curved ends
- Moisture-resistant lower end panel construction
- Energy-saving night curtain
- 1-year parts and labor warranty, 2nd through 5th year part only service compressor



	SHELVES	DIMENSIONS
VFSS3678S	4	36" w x 33" d x 78" h
VFSS4878S	4	47 ¹ / ₄ " w x 33" d x 78" h
VFSS3660S	3	36" w x 33" d x 60" h
VFSS4860S	3	47 ¹ / ₄ " w x 33" d x 60" h



REFRIGERATOR MANUFACTURER
Turbo air

**Super Deluxe Series
Glass Door Merchandiser**

- Two section merchandiser conveniently holds grab-and-go items
- 2 glass swing doors, 8 adjustable, heavy-duty PE coated shelves
- Maintains food-safe temperatures from 33° to 38°F
- Black exterior
- Digital control system
- R-290 hydrocarbon refrigerant
- 5-year parts and labor warranty, 7-year compressor warranty

TGM-47-SDB-N 51½" w x 31½" d x 77" h

Styled to stay cool.

Low-E double
pane glass
doors and
brilliant LED
lighting



Interior
LED lighting

MUR-48-N



REFRIGERATOR MANUFACTURER
Turbo air

M3 Series Undercounter Refrigerators

- Undercounter refrigerator with a field reversible swing door
- Self-cleaning condenser system automatically removes dust
- Stainless steel exterior with PE coated wire shelves
- High-density polyurethane insulation
- Maintains consistent temperatures from 33° to 38°F
- Interior LED lighting provides clear visibility for quick product identification
- Swivel casters with locks on front set
- 5-year parts and labor warranty, 7-year compressor warranty

MUR-28L-N6 1 Doors, 1 Shelves, 27½" w x 30" d x 27½" h
MUR-48-N 2 Doors, 2 Shelves, 48¼" w x 30" d x 30½" h



REFRIGERATOR MANUFACTURER
Turbo air



J Series Undercounter Refrigerator

- Undercounter refrigerator for prep stations
- Side-mount compressor for efficient cooling and easy service
- Holds consistent food-safe temperatures from 33° to 39°F
- Stainless steel exterior, floors and doors with recessed handles
- Energy-efficient R-600 refrigerant
- 2-year parts and labor warranty, 5-year compressor warranty

JUR-48S-N6 2 Doors, 2 Shelves, 47¼" w x 23¾" d x 28¾" h



Chilled to impress.



UCR4833S



UCRSL4833S

Black interior & exterior



Undercounter Square End Refrigerated Display Cases

- Self-serve undercounter design integrates into existing layouts
- Black two-step riser creates a high-contrast display
- Powder-coated steel base and laminate exterior
- Front-access refrigeration system simplifies maintenance
- Recessed casters and adjustable leg levelers
- Black interior and exterior
- R-290 refrigerant
- Squared ends with mirrored liner
- Also available with curved ends
- 1-year parts and labor warranty, 2nd through 5th year part only service compressor



SLIM-LINE

- UCRSL3633S** 35¹/₁₆"w x 24"d x 32¹/₂"h
- UCRSL4833S** 47¹/₁₆"w x 24"d x 32¹/₂"h
- UCRSL6033S** 59¹/₁₆"w x 24"d x 32¹/₂"h
- UCRSL7233S** 71¹/₁₆"w x 24"d x 32¹/₂"h

STANDARD

- UCR3633S** 35¹/₁₆"w x 34"d x 32¹/₂"h
- UCR4833S** 47¹/₁₆"w x 34"d x 32¹/₂"h
- UCR6033S** 59¹/₁₆"w x 34"d x 32¹/₂"h
- UCR7233S** 71¹/₁₆"w x 34"d x 32¹/₂"h



AUR60SD



AUR24SD

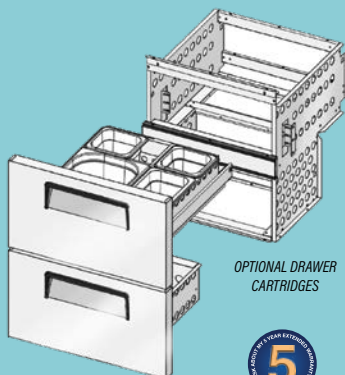

OPTIONAL DRAWER CARTRIDGES



Undercounter Refrigerators & Freezers

- Provides compact, refrigerated storage for prep stations and service lines
- Fits conveniently beneath standard countertops
- Environmentally friendly R-290 refrigerant
- Self-closing solid door(s) or drawers with stay open feature
- Optional Drawer Cartridges
- Stainless steel exterior and interior
- 2-year parts & labor warranty, 5-year compressor part warranty, with option to purchase up to 5-year parts & labor warranty

REFRIGERATORS	DOORS/ SHELVES	DRAWERS	DIMENSIONS
AUR24SD	1/2	—	23 ¹ / ₈ "w x 26"d x 32 ¹ / ₂ "h
AUR27SD	1/1	—	27 ¹ / ₂ "w x 30"d x 32 ¹ / ₂ "h
AUR27D2	—	2	27 ¹ / ₂ "w x 30"d x 32 ¹ / ₂ "h
AUR36SD	1/1	—	36 ³ / ₈ "w x 30"d x 32 ¹ / ₂ "h
AUR36D2	—	2	36 ³ / ₈ "w x 30"d x 32 ¹ / ₂ "h
AUR48SD	2/2	—	48 ¹ / ₄ "w x 30"d x 32 ¹ / ₂ "h
AUR48D4	—	4	48 ¹ / ₄ "w x 30"d x 32 ¹ / ₂ "h
AUR60SD	2/2	—	60 ¹ / ₄ "w x 30"d x 32 ¹ / ₂ "h
AUR60D4	—	4	60 ¹ / ₄ "w x 30"d x 32 ¹ / ₂ "h
AUR72SD	3/3	—	72 ⁵ / ₈ "w x 30"d x 32 ¹ / ₂ "h
AUR72D6	—	6	72 ⁵ / ₈ "w x 30"d x 32 ¹ / ₂ "h
FREEZERS			
AUF24SD	1/2	—	23 ¹ / ₈ "w x 26"d x 32 ¹ / ₂ "h
AUF27SD	1/1	—	27 ¹ / ₂ "w x 30"d x 32 ¹ / ₂ "h
AUF27SD2	—	2	27 ¹ / ₂ "w x 30"d x 32 ¹ / ₂ "h
AUF36SD	2/2	—	36 ³ / ₈ "w x 30"d x 32 ¹ / ₂ "h
AUF48SD	2/2	—	48 ¹ / ₄ "w x 30"d x 32 ¹ / ₂ "h
AUF60SD	2/2	—	60 ¹ / ₄ "w x 30"d x 32 ¹ / ₂ "h



WTCTCS48HC



Cross Temp® Chef Bases

- Operates as a refrigerator or freezer with a temperature range of -15° to 40°F
- Reinforced, insulated top supports heavy countertop cooking equipment
- Stainless steel exterior and corrosion-resistant aluminum interior
- 2 self-closing drawers
- Holds full-size 6" deep food pans
- 34¾"d x 24¾"h
- ½ hp
- 3" casters
- R-290 refrigerant
- 7-year warranty on parts, labor, and compressor

WTCTCS48HC Holds 4 Pans, 48" w
 WTCTCS60HC Holds 6 Pans, 60" w



High performance chilling flexibility.



UC48SN



UC24SNGD-B

Shallow Depth Undercounter Refrigerators

- Front-breathing refrigeration system
- Fits easily into tight kitchen layouts
- Shallow depth profile
- Stainless steel front, top, and sides
- Self-closing, swing doors
- High-efficiency R-290 hydrocarbon refrigerant
- 27¾"d x 31¾"h
- Made in USA
- Pre-installed casters
- 7-year warranty on parts, labor, and compressor



	DOORS	SHELVES	WIDTH	FINISH
UC24SN-B	1 Solid	2	24"	Black Enamel
UC24SNGD-B	1 Glass	2	24"	Black Enamel
UC48SN	2 Solid	4	48"	Stainless Steel
UC48SNGD	2 Glass	4	48"	Stainless Steel



Chef Bases

- The top, front, and lower panel are stainless steel
- Cabinet is made of anodized aluminum with covered corners for easy cleaning
- Heavy-duty one-piece reinforced stainless steel top with marine edge
- Foamed in place CFC-free urethane insulation
- Drawers feature press fit magnetic gaskets
- Electronically controlled natural R-290 refrigeration system
- Heavy-duty casters
- Can hold up to (8) 12" x 20" x 4" pans
- Standard model/lengths available: 38", 48", 53", 72", 82", 105", 120"
- Custom sizes available

LPRES1R2-72C4 72"w, (4) 27" Drawers, Compressor on Right Side
 LPRES1L2-72C4 72"w, (4) 27" Drawers, Compressor on Left Side

Delfield

Low Profile Base Refrigerated Equipment Stands

- Provides refrigerated storage for ingredients directly beneath countertop cooking equipment
- Heavy-duty stainless steel top with a marine edge, drawer fronts, and ends
- Full-extension drawers accommodate 12" x 20" x 4" hotel pans
- R-290 refrigeration system
- Wall-mounted bracket to prevent tipping
- Mounted on casters
- 3-year parts and labor warranty, additional 2-year compressor parts warranty

	DRAWERS	DIMENSIONS
F2936CP	2	36¼" w x 31" d x 24" h
F2952CP	2	52¼" w x 31½" d x 24" h
F2956CP*	2	56¼" w x 31½" d x 24" h
F2960CP	4	60¼" w x 31" d x 24" h
F2962CP*	4	62¼" w x 31½" d x 26" h
F2973CP*	4	73¼" w x 31" d x 24" h
F2975CP	4	75¼" w x 31½" d x 26" h
F2978CP*	4	78¼" w x 31" d x 24" h
F2980CP	4	80¼" w x 31½" d x 26" h
F2987CP	6	87¼" w x 31½" d x 24" h
F2996CP*	6	96¼" w x 31" d x 24" h
F2999CP	6	99¼" w x 31½" d x 26" h
F29110CP	6	110¼" w x 31½" d x 26" h

*ENERGY STAR®



Continental
Refrigerator

**Side-mounted,
slide out
condensing
unit**

Worktop Refrigerators

- Heavy-gauge stainless steel worktop
- Provides a durable prep surface over convenient refrigerated storage
- Forced air design utilizes fans across the entire back of the unit for even temperature distribution
- Side-mounted, slide-out condensing unit simplifies access for routine maintenance
- Stainless steel front and end panels with an aluminum interior
- Spring-loaded, self-closing doors maintain consistent temperatures
- 5" casters
- Made in USA
- 7-year warranty on parts, labor, and compressor

	SHALLOW DOORS	SHELVES	DIMENSIONS
RA43SN	2	2	43" w x 28" d x 35" h
RA60SN	3	4	60" w x 28" d x 35" h
STANDARD			
RA43N	2	2	43" w x 37" d x 35" h
RA60N	3	4	60" w x 37" d x 35" h



TIP

Store, Work & Organize

Chef Bases, Griddle Stands and Worktops offer refrigerated storage, a convenient worktop and plenty of options to keep essential tools close at hand. Built for durability and performance, they are designed to serve as an additional prep area with a refrigerator or freezer below and a reinforced top that can support heavy equipment. Consider these options when selecting the best unit for your needs:

- Base Style - Refrigerator or Freezer
- Drawers/Doors - Single or Multiple
- Reinforced Top - Marine Edge, Overhang or Flat Top
- Compressor Location - Right, Left, Front, Rear or Remote
- Controls - Manual or Digital



Reinforced top with marine edge



Griddle Stands

- Stainless steel interior and exterior
- Environmentally-safe R-290 refrigerant
- High-density, non-CFC polyurethane foam insulation
- Heavy-duty drawer track with built-in safety clips holds up to 250 lb
- 4" casters with support plates
- 35 $\frac{1}{2}$ "d x 26 $\frac{1}{2}$ "h
- Made in USA
- 7-year warranty on parts, labor and compressor

REFRIGERATORS	TOP WEIGHT CAPACITY	DRAWERS	WIDTH
D48GN	775 lb	2	48"
D60GN	1000 lb	2	60"
D84GN	1400 lb	4	84"

FREEZERS	TOP WEIGHT CAPACITY	DRAWERS	WIDTH
D48GFN	775 lb	2	48"
D60GFN	1000 lb	2	60"
D84GFN	1400 lb	4	84"



Your griddle's perfect match.



MGF8448GR



Refrigerated Chef Bases

- Stainless steel construction with one-piece, heavy-duty reinforced top
- Electronic temperature controller
- Maintains temperatures between 34° to 40°F
- Heavy-duty compressor with environmentally friendly R-290 refrigerant
- Stainless steel drawer slides and rollers
- Magnetic drawer gaskets
- Gravity fed self closing drawers
- Pre-installed casters
- Drawers hold and include 6" deep stainless steel pans
- 33" d x 26 $\frac{1}{2}$ " h
- 2-year parts & labor warranty, 5-year compressor warranty, with option to purchase up to 5-year parts & labor warranty

	DRAWERS	WIDTH
MGF8448GR	2	35 $\frac{1}{2}$ "
MGF8450GR	2	48 $\frac{1}{2}$ "
MGF8451GR	2	52"
MGF8452GR	2	60 $\frac{1}{2}$ "
MGF8453GR	4	72 $\frac{1}{2}$ "
MGF8454GR	4	76"



Insulated drawer system with two refrigerated inserts



FX Series Work-Top

- Convertible refrigerator/freezer worktop
- Precise temperature control from -4° to 40°F, holds foods at proper temperatures
- Insulated drawer system with two refrigerated inserts provides 100% in-drawer cooling
- Electronically controlled R-290 and 100% front breathing
- Individual compressor per drawer
- High grade stainless steel exterior and interior
- 3 $\frac{1}{2}$ " casters



FX-2WS-290 2 Drawers, 43 $\frac{1}{4}$ "w x 28" d x 36 $\frac{1}{4}$ "h

Worktops with Backsplash

- Stainless steel exterior & interior with reinforced stainless steel top
- Foamed in place backsplash
- R-290 refrigerant
- Electronic temperature controller
- Refrigerators maintain temperatures between 35° to 38°F, Freezers -8° to 0°F
- Recessed door handle(s)
- Self-closing, solid swing door(s) with stay open feature
- One (1) pre-installed shelf per section
- 30"d x 39½"h
- 2-year parts & labor warranty, 5-year compressor part warranty, with option to purchase up to 5-year parts and labor warranty



MGF8409GR

Pre-installed casters



REFRIGERATORS	DOORS	SHELVES	WIDTH
MGF8408GR	1	1	27½"
MGF8409GR	2	2	48¾"
MGF8410GR	2	2	60½"

FREEZERS	DOORS	SHELVES	WIDTH
MGF8412GR	1	1	27½"
MGF8413GR	2	2	48¾"

REFRIGERATORS



FREEZERS



Unique air flow distribution



Sandwich Prep Tables

- Stainless steel top, front and end panels, aluminum back and interior
- Natural, environmentally-safe, high-efficiency R-290 refrigerant
- Unique air flow distribution
- Heavy-duty, epoxy-coated steel shelves
- Includes ½ size, 4" deep pans
- 5" casters
- 115V
- 32¾"d x 42¼"h
- Made in the USA



SW48N8	Holds 8 pans, 2 Doors, 2 Shelves, 48" w, ¼+ hp
SW60N12	Holds 12 pans, 2 Doors, 2 Shelves, 60" w, ¼+ hp



Countertop Rail Prep Station

- Holds (4) ½ size pans at a food-safe 41°F
- Converts any work surface into a refrigerated prep line
- Interior and exterior front, sides, and top are constructed of stainless steel
- Coved corner stainless steel interior liner with a recessed pan ledge and adapter bars
- R-290 refrigerant
- Exterior-mounted electronic controls

CR9046-290 46" w x 18" d x 23½" h



Converts any work surface into a refrigerated prep line



RTR-8



RTR-4

Refrigerated Topping Rails

- All stainless steel construction
- Refrigerated countertop system keeps everything at safe food temperatures
- Includes ½ size, 4" deep polycarbonate pans with hinged covers
- All pans are removable for easy cleaning
- ½" non-adjustable legs
- 1-year parts and labor warranty

	PANS	DIMENSIONS
RTR-4	4	17" w x 26" d x 11½" h
RTR-8	8	28¾" w x 27" d x 9½" h



REFRIGERATION



DP60HC

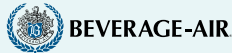

Deli/Pizza Prep Tables

- Integrates refrigerated pan storage
- Deep, removable cutting board for streamlined preparation
- Stainless steel exterior and corrosion-resistant aluminum interior
- Raised rail maintains consistent 36° to 38°F temperatures for food-safe ingredient holding
- Self-closing doors with stay-open feature and heavy-duty drawer slides
- 38½" d x 54¾" h



DP60HC 2 Solid Doors, 4 Shelves, 60" w
DPD72HC-2 1 Solid Door, 2 Drawers, 2 Shelves, 72" w



SPED60HC-12M-2



Sandwich Prep Tables

- Combines refrigerated storage and a work surface
- Streamlines sandwich and salad prep
- Stainless steel exterior with a corrosion-resistant aluminum interior
- Wide, removable polyethylene cutting board
- Energy-efficient R-290 refrigerant
- Maintains temperatures between 36° to 38°F
- Self-closing doors with a 120° stay-open feature
- 7-year warranty on parts, labor, and compressor



SPE48HC-08 2 Solid Swing Doors, 4 Shelves, Includes (8) ½ size 4" deep pans, 48" w x 32" d x 45¼" h
SPED60HC-12M-2 Mega Top, 1 Solid Swing Door, 2 Shelves, Includes (12) ½ size 4" deep pans, 60" w x 38¾" d x 49" h



SW48N12M

Unique air flow distribution



Mighty Top Sandwich Prep Tables

- Stainless steel top, front and end panels, aluminum back and interior
- Natural, environmentally-safe, high-efficiency R-290 refrigerant
- Unique air flow distribution allows pan product to maintain 33° to 41°F
- Heavy-duty, epoxy-coated steel shelves
- Electronic controller w/digital display and hi-low alarm
- 5" casters
- Made in USA
- 7-year warranty on parts, labor, and compressor



SW48N12M Includes (12) ½-size pans, 48" w x 35" d x 42¼" h
SW60N24M Includes (24) ½-size pans, 60" w x 35" d x 42¼" h



RA60SN8

Base Model Sandwich Prep Tables

- Performance-driven with a refrigerated base, integrated pan rail and a full-length cutting board
- Forced-air design directs cold air over top pans
- Maintains consistent, food-safe temperatures
- Stainless steel top, front, and sides with a 12" d nylon cutting board
- Self-closing, field-rehingeable doors
- Slide-out condensing unit allows for easy access during routine maintenance
- 5" casters
- Includes ½-size, 4" deep pans
- Made in USA
- 7-year warranty on parts, labor, and compressor



	SHALLOW DOORS	SHELVES	PANS	DIMENSIONS
RA43SN6	2	2	6	43" w x 28" d x 42" h
RA60SN8	3	4	8	60" w x 28" d x 42" h
STANDARD				
RA43N6	2	2	6	43" w x 37" d x 42" h
RA60N8	3	4	8	60" w x 37" d x 42" h

Salad Top Prep Tables

- Front breathing design
- Patented air screen maintains ingredient temperature without dehydration
- Stainless steel exterior and a dent-resistant ABS interior
- Integrated polyethylene cutting board
- 1 epoxy coated wire shelf standard, installed per door section
- Standard on 5" casters
- ½ size pans included
- R-290 refrigerant
- 3-year parts and labor warranty, additional 2-year compressor parts warranty



4427NP-6

	DOORS/ SHELVES	PANS	DIMENSIONS
4427NP-6	1/1	6	27½" w x 31½" d x 42½" h
4427NP-8	1/1	8	27½" w x 31½" d x 42½" h
4448NP-6	2/2	6	48½" w x 31½" d x 44½" h
4448NP-8	2/2	8	48½" w x 31½" d x 44½" h
4448NP-12	2/2	12	48½" w x 31½" d x 42½" h
4460NP-8	2/2	8	60½" w x 31½" d x 42½" h
4460NP-12	2/2	12	60½" w x 31½" d x 42½" h
4464NP-8	2/2	8	64½" w x 31½" d x 42½" h
4464NP-12	2/2	12	64½" w x 31½" d x 42½" h
4464NP-16	2/2	16	64½" w x 31½" d x 42½" h
4472NP-12	3/3	12	72½" w x 31½" d x 42½" h
4472NP-18	3/3	18	72½" w x 31½" d x 42½" h



Delfield



Mega Top Sandwich/Salad Prep Tables

- Front-breathing refrigeration allows for zero-clearance installation against walls
- Patented air screen technology
- Stainless steel exterior with a dent- and corrosion-resistant ABS plastic interior
- Integrated 8" wide polyethylene cutting board
- R-290 refrigerant
- Includes ½ sized pans
- Standard on 5" casters
- 31½" d
- 3-year parts and labor warranty, additional 2-year compressor parts warranty



4427NP-12M

Patented air screen technology

Delfield



	DOORS/ SHELVES	PANS	DIMENSIONS
4427NP-9M	1/1	9	27½" w x 36" h
4427NP-12M	1/1	12	27½" w x 36" h
4448NP-6M	2/1	6	48½" w x 44½" h
4448NP-12M	2/1	12	48½" w x 44½" h
4448NP-18M	2/1	18	48½" w x 44½" h
4460NP-12M	2/2	12	60½" w x 44½" h
4460NP-18M	2/2	18	60½" w x 44½" h
4464NP-12M	2/2	12	64½" w x 44½" h
4464NP-18M	2/2	18	64½" w x 44½" h
4464NP-24M	2/2	24	64½" w x 44½" h
4472NP-18M	3/3	18	72½" w x 44½" h
4472NP-24M	3/3	24	72½" w x 44½" h
4472NP-30M	3/3	30	72½" w x 44½" h



4448NP-18M

Fresh prep starts here.



Sandwich/Salad Tables

- Includes 1/2 size pans, 4" deep pans
- Cold Bunker system maintains food temperature at under 41°F
- 2 solid swing doors with 2 shelves
- Self-cleaning condenser system standard
- 9 1/2" deep, full-length high-density polyethylene cutting board
- Stainless steel exterior (galvanized back and bottom)
- Aluminum interior wall, stainless steel interior floor and wire coated shelves
- 5-year parts and labor warranty, 7-year warranty on compressor



MST-48-N



Cold bunker system



MST-60-24-N

MST-48-N Standard, 12 Pans, 48 1/4" w x 30" d x 37 1/2" h
MST-60-24-N Mega Top, 24 Pans, 60 1/4" w x 34" d x 39 3/8" h

Build better sandwiches fast.

Refrigerated Sandwich Prep Tables

- Stainless steel exterior and interior
- Environmentally friendly R-290 refrigerant
- Electronic temperature controller
- Includes 1/2-size 6" deep poly food pans
- Maintains temperatures between 35° to 38°F
- Recessed door handle(s)
- Self-closing, solid swing door(s) with stay open feature
- Magnetic door gasket
- Pre-installed casters
- 2-year parts & labor warranty, 5-year compressor part warranty, with option to purchase up to 5-year parts & labor warranty



MSF8301GR

Self-closing solid swing door with stay open feature



SLIM TOP	DOORS	SHELVES	PANS	DIMENSIONS
MSF17GR-NTCV	1	2	8	17 1/2" w x 41 1/2" d x 36 3/8" h
STANDARD TOP				
MSF8301GR	1	1	8	27 1/2" w x 30" d x 41 1/2" h
MSF3610GR	2	2	10	36 3/8" w x 30" d x 41 1/2" h
MSF8302GR	2	2	12	48" w x 30" d x 41 1/2" h
MSF8303GR	2	2	16	60" w x 30" d x 41 1/2" h
MSF8304GR	3	3	18	72" w x 30" d x 41 1/2" h
MEGA TOP				
MSF8305GR	1	1	12	27 1/2" w x 34" d x 44 1/4" h
MSF3615GR	2	2	12	36 3/8" w x 34" d x 44 1/4" h
MSF8306GR	2	2	18	48" w x 34" d x 44 1/4" h
MSF8307GR	2	2	24	60" w x 34" d x 44 1/4" h
MSF8308GR	3	3	30	72" w x 34" d x 44 1/4" h



MSF8308GR



Sandwich/Salad Prep Tables

- All stainless steel front, top & sides
- Clear coated aluminum liner, stainless steel floor with covered corners
- Natural refrigerant
- Holds 33° to 41°F
- Work surface 36" high
- Includes 1/2 size 4" deep, clear polycarbonate insert pans
- Mega Top units: 34 1/8" d x 40 3/8" h, Standard units: 30 3/8" d x 36 3/8" h
- Includes 5" casters (height does not include 6 1/4" for casters or 6" for optional legs)
- 7-year labor, 7-year parts, 7-year compressor warranty

Full length removable polyethylene cutting board



TSSU-48-12-HC

STANDARD	DOORS	SHELVES	WIDTH	PANS
TSSU-27-08-HC	1	2	27 7/8"	8
TSSU-36-08-HC	2	4	36 3/8"	8
TSSU-48-12-HC†	2	4	48 3/8"	12
TSSU-60-16-HC	2	4	60 3/8"	16
TSSU-72-18-HC	3	6	72 3/8"	18

MEGA TOP	DOORS	SHELVES	WIDTH	PANS
TSSU-27-12M-C-HC*	1	2	27 7/8"	12
TSSU-36-12M-B-HC	2	4	36 3/8"	12
TSSU-48-18M-B-HC†	2	4	48 3/8"	18
TSSU-60-24M-B-ST-HC	2	4	60 3/8"	24
TSSU-72-30M-B-ST-HC	3	6	72 3/8"	30

†CE
*Width for TSSU-27-12M-C-HC does not include 1/2" each side for lid pins



Mega Top Food Prep Tables

- Forced-air refrigeration maintains consistent, food-safe temperatures from 33° to 41°F
- Stainless steel front, top, and ends
- Clear coated aluminum liner
- Stainless steel floor with covered corners
- 8" deep, full-length polyethylene cutting board
- Natural refrigerant
- Heavy-duty stainless steel drawer slides and rollers
- Includes 1/2 size, 4" deep polycarbonate food pans
- Drawers hold 12" x 20" x 6" pans (not included)
- Door variations are also available
- 31 1/2" d x 45 3/4" h
- 7-year labor, 7-year parts, 7-year compressor warranty



TFP-32-12M-D-2-HC

	DRAWERS	WIDTH	PANS
TFP-32-12M-D-2-HC	2	32 1/2"	12
TFP-48-18M-D-4-HC	4	48 1/2"	18
TFP-64-24M-D-4-HC	4	64 1/2"	24
TFP-72-30M-D-6-HC	6	72 1/2"	30



Performance that keeps its cool.

Recessed 2 1/2" casters



Delfield

Refrigerated Pizza Prep Tables

- Top, sides and ends are constructed of 18-gauge stainless steel
- High density, polyurethane foam insulation
- Removable, stainless steel hinged covers
- Refrigerated rail maintains 33° to 41°F
- 115V
- Fits 1/2 sized pans
- 32½" d x 42" h
- 3-year parts and labor warranty and an additional 2-year compressor parts warranty

	DOORS/ SHELVES	PANS	WIDTH
18648PTBMP	1/1	12	48"
18660PTBMP	2/2	14	60"
18672PTBMP	2/2	18	72"
18691PTBMP	3/3	22	91"
18699PTBMP	3/3	24	99"
186114PTBMP	3/6	28	114"

Toppings within Reach.



Pizza Prep Tables

- All stainless steel front, top and sides
- Corrosion-resistant GalFan coated steel back
- Stainless steel, patented, foam insulated flat lids keep pan temperatures colder, lock in freshness, and minimize condensation
- 19½" d full length removable cutting board
- 5" casters
- 33½" d x 38½" h
- Holds 12" x 20" x 8" pans
- R-290 refrigerant
- Forced-air design holds 33° to 41°F
- Solid swing doors with adjustable wire shelving
- 7-year labor, 7-year parts, 7-year compressor warranty

Oversized workspace meets fast-paced demands



	DOORS	SHELVES	WIDTH	PANS
TPP-AT-44-HC	1	2	44½"	6
TPP-AT-67-HC	2	4	67½"	9
TPP-AT-60-HC	2	4	60¼"	8
TPP-AT2-93-HC	3	6	93½"	12
TPP-AT-119-HC	4	8	119¼"	15



TPP-AT-60-HC



Pizza Prep Tables

- Heavy-gauge stainless steel top, front and end panels
- Natural, environmentally-safe, high-efficiency R-290 refrigerant
- Refrigerated section with half-door above condensing unit
- 2" non-CFC polyurethane foam insulation
- Spring loaded, self closing, half doors
- Heavy-duty, epoxy-coated steel shelves
- Full length nylon cutting board
- 5" casters
- 38½" d x 39" h
- Made in USA
- 7-year warranty on parts, labor, and compressor



	DOORS	DRAWERS	PAN CAPACITY	WIDTH
PA43N-D	1	2	(4) ½ & (1) ½	43"
PA60N-D	1	4	(8) ½	60"
PA68N-D	1	4	(9) ½	68"
PA93N-D	1	6	(12) ½	93"



TIP

The Heart of Pizza Production

Pizza prep tables are designed to keep every ingredient within easy reach while providing ample workspace for building large pies. A refrigerated raised rail keeps toppings fresh and ready to use, while cold wall, forced air or hybrid cooling systems maintain safe temperatures between 33°F and 41°F. The result? Faster prep, consistent quality, and perfectly chilled ingredients from the first pizza to the last.



Pizza Prep Tables

- Cold-wall conductive cooling create a blanket of cold above pans to ensure safe product temperature
- Independent electronic temperature control for rail and base allows precise temperature control in each zone
- Rail on/off allows nightly shutdown for up to 60% energy savings
- Completely sealed pan rail with clean-out valve
- Interior LED lighting
- Factory installed 6" casters, (front-locking)
- 6 standard sizes available, along with multiple configurable options



Full-depth interior maximizes refrigerated storage space

Mega Top Prep Tables

- Cold-wall conductive cooling create a blanket of cold above pans to ensure safe product temperature
- Independent electronic temperature control for rail and base allows precise temperature control in each zone
- Rail on/off allows nightly shutdown for up to 60% energy savings
- Completely sealed pan rail with clean-out valve
- Interior LED lighting
- Factory installed 6" casters, (front-locking)
- 3 standard sizes available, along with multiple configurable options



ICE MACHINES



TIP

Elevate Every Drink

Great drinks start with great ice. Clear, clean-tasting ice can elevate every beverage you serve and leave a lasting impression on guests. Using a water filtration system helps improve ice quality while reducing scale buildup, extending equipment life and minimizing maintenance costs. Regular filter changes ensure consistent ice product and help protect your ice machine investment.

eurolib

Resolute Ice Cubers

- Stainless steel and ABS plastic construction
- Control panel adjusts ice thickness, cleaning cycle, ice-making phase, cleaning phase, and error codes
- Air-cooled system with removable air filter
- Gravity drain
- Uses R-290 refrigerant
- 27⁵/₈" w x 26" d
- 3-year parts and labor warranty, 5-year warranty on compressor



ICB16080

ICB16080 160 lb Ice Production*, 35³/₈"h

ICB28080 280 lb Ice Production*, 38¹/₂"h

*Ice production based on 70°F air/50°F water in a 24-hour period.

**80 lb
storage
capacity**

Built for the perfect cube.



Ice Machines

- Self-contained, air-cooled design for efficient ice production
- Stainless steel exterior
- Removable air filter and screwless front panel
- Ice machines produce half-cube ice
- Ice bins feature food-grade plastic liners
- Includes R-290 refrigerant and 3M filtration systems
- 2-year parts & labor warranty, 5-year compressor part warranty, ice machine comes with option to purchase up to 5-year parts & labor warranty

ICE MACHINES	DIMENSIONS	ICE PRODUCTION*	VOLTAGE
YRS0350A-161	22 ³ / ₄ "w x 24 ¹ / ₄ "d x 22"h	350 lb	115V
YRS0450A-161	22 ³ / ₄ "w x 24 ¹ / ₄ "d x 25 ³ / ₄ "h	450 lb	115V
YRS0600A-261	22 ³ / ₄ "w x 24 ¹ / ₄ "d x 31 ³ / ₄ "h	600 lb	208-230V
YRM0450A-161	30 ³ / ₄ "w x 24 ¹ / ₄ "d x 22"h	450 lb	115V
YRM0600A-261	30 ³ / ₄ "w x 24 ¹ / ₄ "d x 25 ³ / ₄ "h	600 lb	208-230V
YRM0800A-261†	30 ³ / ₄ "w x 24 ¹ / ₄ "d x 31 ³ / ₄ "h	800 lb	208-230V
YRM1000A-261†	30 ³ / ₄ "w x 24 ¹ / ₄ "d x 35"h	1000 lb	208-230V

UNDERCOUNTER	DIMENSIONS	ICE PRODUCTION*	VOLTAGE
YRU0140A-161	24 ¹ / ₄ "w x 28 ³ / ₄ "d x 38 ¹ / ₂ "h	142 lb	115V
YRU280A-161	24 ¹ / ₄ "w x 28 ³ / ₄ "d x 38 ¹ / ₂ "h	283 lb	115V

ICE MACHINE W/ BIN	DIMENSIONS	ICE PRODUCTION*	VOLTAGE
YDS035A-161	23"w x 29 ¹ / ₂ "d x 70 ³ / ₄ "h	350 lb	115V

ICE BINS	DIMENSIONS	STORAGE CAP.
BYR0300†**	22 ¹ / ₂ "w x 32 ¹ / ₄ "d x 41 ¹ / ₂ "h	300 lb
BYR0400†	30 ³ / ₄ "w x 32 ¹ / ₄ "d x 41 ¹ / ₂ "h	400 lb
CYR700P†	48 ¹ / ₄ "w x 32 ¹ / ₄ "d x 41"h	700 lb

*Ice production per 24 hours based on 70° Air/50°F Water †not ENERGY STAR
** 5-year parts and labor warranty, 5-year compressor warranty

ATOSA®



BYR0300

**Features
food-grade
plastic liners**



Modular Ice Machines

- Air-cooled modular cubers produce full or half-size ice cubes
- 304 stainless steel exterior with an antimicrobial ABS interior
- Diagnostic control panel on front, internal multi-functional panel
- 3-way ventilation for maximum efficiency and placement flexibility
- Air filter with magnetic frame for easy removal
- Hinged front panel with side and top vents
- 3-year parts and labor warranty on ice maker, 5-year parts and labor warranty on evaporator, 5-year parts warranty on compressor



IM-0550-AC

IM-0550-AC W/ OPTIONAL IB-033 BIN

IM-0460-AC-22

	ICE PRODUCTION*	DIMENSIONS
FULL CUBE		
IM-0460-AC-22	443 lb	22" w x 24 1/2" d x 22 3/8" h
IM-0550-AC	551 lb	30" w x 24 1/2" d x 22 3/8" h
IM-0750-AC	737 lb	30" w x 24 1/2" d x 22 3/8" h
IM-1100-AC	1106 lb	30" w x 24 1/2" d x 30 3/8" h
IM-1700-AC	1722 lb	48" w x 24 1/2" d x 30 3/8" h
IM-2000-AC	2032 lb	48" w x 24 1/2" d x 30 3/8" h

	ICE PRODUCTION*	DIMENSIONS
HALF CUBE		
IM-0460-AH-22	443 lb	22" w x 24 1/2" d x 22 3/8" h
IM-0550-AH	551 lb	30" w x 24 1/2" d x 22 3/8" h
IM-0750-AH	737 lb	30" w x 24 1/2" d x 22 3/8" h
IM-1100-AH	1106 lb	30" w x 24 1/2" d x 30 3/8" h
IM-1700-AH	1722 lb	48" w x 24 1/2" d x 30 3/8" h
IM-2000-AH	2032 lb	48" w x 24 1/2" d x 30 3/8" h

*Ice production per 24 hours based on 70° Air/50°F Water



Reliable ice, every time.

FOLLETT PerfectCUBE

- Produces up to 475 lb of 1 1/4" square full cubes in 24 hours
- 304 stainless steel exterior with an ABS antimicrobial interior
- Hinged front panel with side and top vents
- R290A refrigerant
- Air-cooled modular head, 30" wide
- 3-year parts and labor warranty, 5-year parts warranty on compressor



Diagnostic control panel and automatic cleaning cycle

IM-0485-AQ 30" w x 28 1/2" d x 32" h





easyTouch®
Display with
intelligent
diagnostics

Indigo® NXT Series Easy-Ice Machines

- Intelligent diagnostics - provide 24 hour preventative maintenance and diagnostic feedback for trouble-free operation
- Select components made with AlphaSan® antimicrobial
- DuraTech™ exterior - with an innovative clear coat that provides superior corrosion resistance and resists fingerprints
- Easy to clean food-zone - easy access and fast and efficient parts removal
- Available in dice and half-dice options
- 3-year parts and labor warranty on ice maker, 5-year parts and labor warranty on evaporator; and 5-year parts, 3-years labor warranty on compressor



IDP0500 SHOWN
ON D400 BIN

IDP0450 SHOWN
ON D570 BIN

DICE CUBE	WIDTH	ICE PRODUCTION*	VOLTAGE
IDP0420A-161	22"	463 lb	115V
IDP0500A-161	30"	515 lb	115V
IDP0300A-161	30"	309 lb	115V
IDP0450A-161	30"	463 lb	115V
IDP0600A-261	30"	662 lb	115, 208-230V
IDP0620A-161	22"	482 lb	208-230V
IDP0800A-261	30"	775 lb	208-230V
IDP1000A-261	30"	970 lb	208-230V

HALF DICE CUBE	WIDTH	ICE PRODUCTION*	VOLTAGE
IYP0420A-161	22"	437 lb	115V
IYP0600A-261	30"	672 lb	115, 208-230V
IYP0300A-161	30"	325 lb	115V
IYP0450A-161	30"	478 lb	115V
IYP0500A-161	30"	516 lb	115V
IYP0620A-161	22"	537 lb	208-230V
IYP0800A-261	30"	745 lb	208-230V
IYP1000A-261	30"	971 lb	208-230V

*Ice production per 24 hours based on 70° Air/50°F Water



Effortless ice flow, peak performance.



Ice Storage Bins

- Bin door stays open while scooping ice
- Internal scoop holder stays above ice line for easy access and better sanitation
- 3-year parts and labor warranty

	DIMENSIONS	ICE STORAGE CAPACITY
D320	22" w x 34" d x 38" h	264 lb
D400	30" w x 34" d x 38" h	365 lb
D420	22" w x 34" d x 50" h	383 lb
D570	30" w x 34" d x 50" h	532 lb
D970	48" w x 34" d x 50" h	882 lb



D400

DuraTech™
stainless finish
exterior



D570



UDP0310A-161B

Slide-up door for easy access



NEO® Undercounter Ice Machines

- Forward-sliding/removable storage bin
- Easy-to-clean food-zone
- Delay function for slow periods
- Available in regular, dice and half-dice options
- Natural R-290 refrigerant
- Integrated water filtration
- Smart controls
- 115V
- 3-year parts and labor warranty on ice maker, 5-year parts and labor warranty on evaporator, 5-year parts and 3-year labor warranty on compressor



UDP0140A-161B

DICE CUBE	WIDTH	ICE PRODUCTION*	ICE STORAGE CAPACITY
UDP0140A-161B	26"	140 lb	90
UDP0190A-161B	26"	200 lb	90
UDP0240A-161B	26"	240 lb	90
UDP0310A-161B	30"	330 lb	100

HALF DICE CUBE	WIDTH	ICE PRODUCTION*	ICE STORAGE CAPACITY
UYP0140A-161B	26"	150 lb	90
UYP0190A-161B	26"	200 lb	90
UYP0240A-161B	26"	250 lb	90
UYP0310A-161B	30"	330 lb	100

*Ice production per 24 hours based on 70° Air/50°F Water



Automatic Cleaning System

- Automated system keeps ice machines clean and running
- Programmable cycles prevent scale buildup and costly service calls
- Mounts easily on walls or bins
- Stainless steel construction
- Designed for use with Manitowoc Indigo series ice cubers
- 3-year parts and labor warranty

iAUCS-161 12" w x 3 3/4" d x 12 1/4" h



LuminIce® II Virus Eliminator Bacteria Inhibitor

- Automated sanitation defends against mold, yeast, and bacteria
- Reduces labor costs and downtime from frequent cleanings
- Integrates seamlessly with Manitowoc Indigo NXT displays
- Guards against potential health inspection violations
- 3-year parts and labor warranty, 90-day UV bulb warranty

K-00464 4" w x 2 1/2" d x 5" h



ICE MACHINES

Prodigy® Elite Modular Cube Ice Machines

- Integrated ICELINQ® app provides real time diagnostics, support and control
- AutoAlert™ panel displays machine status and alerts
- Antimicrobial protection guards internal surfaces
- WaterSense adaptive purge optimizes water consumption
- R-290 refrigerant
- Environmentally-friendly refrigerant
- Removable, external air filter
- Produces small or medium cubes of ice
- Air-cooled design
- 115V, some models available in 208-230V
- 3-years parts and labor on all components, 5-years parts and labor on the evaporator, 5-years parts on the compressor and condenser

Scotsman



MC0522SAX-1, MC0522SAX-1,
MC0722SAX-1, MC0722MAX-1



MC0722MAX-1

Designed, engineered and assembled in the USA



MC0330SAX-1

	ICE PRODUCTION*	DIMENSIONS		ICE PRODUCTION*	DIMENSIONS
SMALL CUBE			MEDIUM CUBE		
MC0330SAX-1	365 lb	30" w x 24" d x 23" h	MC0330MAX-1	365 lb	30" w x 24" d x 23" h
MC0522SAX-1	464 lb	22" w x 24" d x 23" h	MC0522MAX-1	464 lb	22" w x 24" d x 23" h
MC0530SAX-1	476 lb	30" w x 24" d x 23" h	MC0530MAX-1	476 lb	30" w x 24" d x 23" h
MC0722SAX-1	734 lb	22" w x 24" d x 29" h	MC0722MAX-1	734 lb	22" w x 24" d x 29" h

*Ice Production per 24 hours based on 70° Air/50°F Water

Modular Storage Bins

- Convenient, built-in scoop holder
- Unique recessed drain fitting for maximum installation flexibility
- Fits Prodigy Elite and Prodigy Plus
- Spring loaded door with hidden hinges for easy opening and closing
- Polyurethane foam insulation and interior bin
- Height includes 6" legs
- 3-year parts and labor warranty on all components



B322S

STAINLESS STEEL	STORAGE CAPACITY	DIMENSIONS
B322S	370 lb	22" w x 34" d x 50" h
B530S	536 lb	30" w x 34" d x 50" h
B948S	893 lb	48" w x 34" d x 50" h

ROTOCAST PLASTIC	STORAGE CAPACITY	DIMENSIONS
B330P	344 lb	30" w x 34" d x 37" h
B530P	536 lb	30" w x 34" d x 50" h

Scotsman



Scotsman

iceValet® Hotel Dispensers

- Stores and dispenses ice with a simple push chute
- Corrosion resistant metallic cabinet
- Polyurethane insulation
- Push controls
- Pairs with compatible Scotsman ice machines
- Height includes 6" legs
- 3-year parts and labor warranty on all components



HD22B-1



HD30B-1

HD22B-1	120 lb Storage Capacity, 22" w x 33½" d x 53¼" h
HD30B-1	180 lb Storage Capacity, 30" w x 33½" d x 53¼" h



Prodigy Plus® Flake & Nugget Ice Machines

- Choose the perfect model for flake ice, soft or hard nugget ice
- Self-diagnostic technology with AutoAlert™ indicator lights
- R-290 refrigerant
- 115V, some models available in 208-230V
- 3-year parts and labor warranty on all components, 5-year warranty on compressor parts

FLAKE	ICE PRODUCTION*	DIMENSIONS
FS0522AX-1	450 lb	22" w x 24" d x 23" h
FS0822AX-1	800 lb	22" w x 24" d x 23" h

SOFT NUGGET	ICE PRODUCTION*	DIMENSIONS
NS0422AX-1	430 lb	22" w x 24" d x 23" h
NS0922AX-1	956 lb	22" w x 24" d x 27" h

HARD NUGGET	ICE PRODUCTION*	DIMENSIONS
NH0422AX-1	375 lb	22" w x 24" d x 23" h
NH0922AX-1	862 lb	22" w x 24" d x 27" h

*Ice Production per 24 hours based on 70° Air/50°F Water

FS0522AX-1



Front-breathing and air cooled design



Scotsman



NH1322AX-32

Scotsman

Meridian™ Series Ice & Water Dispensers & Stands

- Dispenses chewable nugget ice and water from a single unit
- Antimicrobial-molded components and a sealed refrigeration system
- Internal UV module actively filters incoming water
- Integrated drain cover and consolidated drain
- Fully removable air filter, spouts, sink, grill and bin
- Air cooled design
- Stainless steel construction and sealed bearings
- AutoAlert™ indicator panel
- R-290 refrigerant
- Stands have an enclosed cabinet with a stainless steel interior shelf, a reversible locking door and adjustable 6" legs
- Stand heights include 6" legs
- Ice dispensers have a 3-year parts and labor on all components, 5-years warranty on compressor and condenser parts
- Stands have a 1-year parts and labor on all components

HID207ABX-1



HID525ABX-1



HID312AX-1



Push button sensor or touch free controls

COMPACT (16¹/₈"w x 23³/₈"d x 17¹/₂"h)

- HID207ABX-1** Push Button, 196 lb per day, 7 lb Storage Capacity
HID207AX-1 Touch Free, 196 lb per day, 7 lb Storage Capacity

STANDARD (21¹/₄"w x 24³/₈"d x 35" h)

- HID525ABX-1** Push Button, 500 lb per day, 25 lb Storage Capacity
HID525AX-1 Touch Free, 500 lb per day, 25 lb Storage Capacity

STANDARD (16¹/₈"w x 24³/₈"d x 35" h)

- HID312ABX-1** Push Button, 320 lb per day, 12 lb Storage Capacity
HID312AX-1 Touch Free, 320 lb per day, 12 lb Storage Capacity

STANDS

- HST16-A** 16¹/₂"w x 23³/₈"d x 32" h
HST21-A 21¹/₂"w x 23³/₈"d x 32" h

*Ice Production per 24 hours based on 70° Air/50°F Water



HST16-A

Scotsman

NSF, UL LISTED, ETL Intertek, ENERGY STAR

Undercounter Flake & Nugget Ice Machines with Storage

- Produces soft, flake or nugget ice
- Front breathing, air cooled design
- Aluminum alloy side panels
- Stainless steel evaporator and auger
- R-290 refrigerant
- Height includes 6" legs
- 3-year parts and labor warranty on all components
- Flake ice machines have a 5-year compressor part warranty

UF0915AX-1, UN324AX-1

FLAKE ICE	ICE PRODUCTION*	STORAGE CAPACITY	DIMENSIONS
UF0915AX-1	96 lb	36 lb	15" w x 24" d x 38" h
UF1415AX-1	142 lb	36 lb	15" w x 24" d x 38" h
UF2020AX-1	216 lb	57 lb	20" w x 24" d x 38" h
UF424AX-1**	440 lb	80 lb	24" w x 28 ¹ / ₂ " d x 39" h
NUGGET ICE			
UN0815AX-1	99 lb	36 lb	15" w x 24" d x 38" h
UN1215AX-1	129 lb	36 lb	15" w x 24" d x 38" h
UN1520AX-1	167 lb	57 lb	20" w x 24" d x 38" h
UN324AX-1†**	340 lb	80 lb	24" w x 28 ¹ / ₂ " d x 39" h

*Ice Production per 24 hours based on 70° Air/50°F Water
 ** cETLus, not cULus
 †ENERGY STAR® certified & includes 5-year compressor part warranty

Scotsman

Self-Contained Undercounter Cube Ice Machines

- Provides a complete ice production and storage system
- Upward-sliding door with included ice scoop
- R-290 refrigerant
- User-friendly controls
- Makes small or medium sized cubes
- Heavy-duty, rust-free front panel and corrosion-resistant aluminum alloy side panels
- Height includes 6" legs
- 3-year parts and labor warranty on all components

CU0415MAX-1, CU0920MAX-1

NSF, ETL Intertek, ETL Intertek

SMALL	ICE PRODUCTION*	STORAGE CAPACITY	DIMENSIONS
CU3030SAX-1†	329 lb	110 lb	30" w x 30" d x 33" h
MEDIUM			
CU0415MAX-1	60 lb	36 lb	15" w x 24" d x 38" h
CU0715MAX-1	80 lb	36 lb	15" w x 24" d x 38" h
CU0920MAX-1	100 lb	57 lb	20" w x 24" d x 38" h
CU3030MAX-1†	329 lb	110 lb	30" w x 30" d x 33" h

*Ice Production per 24 hours based on 70° Air/50°F Water
 †NSF, not ETL Sanitation



Cube Ice Makers

- Makes full cube or half cubes of ice
- Harvest Assist technology delivers consistent ice production
- Corrosion-resistant aluminum construction with nickel-plated evaporator plates
- Snap-in, front facing evaporator and dishwasher safe components (up to 180°F)
- Made in USA
- 3-year parts and labor warranty on ice maker, 5-year parts and labor warranty on evaporator and compressor



Innovation elevated with simplified controls



CIM0530HA90
ON OPTIONAL
B55 BIN

AIR-COOLED	CUBE TYPE	REFRIGERANT	WIDTH	ICE PRODUCTION*
CIM0320HA90	Half	R-290	22 $\frac{1}{4}$ "	325 lb
CIM0320FA90	Full	R-290	22 $\frac{1}{4}$ "	325 lb
CIM0330HA90	Half	R-290	30 $\frac{1}{4}$ "	325 lb
CIM0330FA90	Full	R-290	30 $\frac{1}{4}$ "	325 lb
CIM0430HA90	Half	R-290	30 $\frac{1}{4}$ "	435 lb
CIM0430FA90	Full	R-290	30 $\frac{1}{4}$ "	435 lb
CIM0520HA90	Half	R-290	22 $\frac{1}{4}$ "	525 lb
CIM0520FA90	Full	R-290	22 $\frac{1}{4}$ "	525 lb
CIM0530HA90	Half	R-290	30 $\frac{1}{4}$ "	525 lb
CIM0530FA90	Full	R-290	30 $\frac{1}{4}$ "	525 lb
CIM0636HA90	Half	R-290	30 $\frac{1}{4}$ "	600 lb
CIM0636FA90	Full	R-290	30 $\frac{1}{4}$ "	600 lb
CIM0836GA90	Grand	R-290	30 $\frac{1}{4}$ "	850 lb
CIM0826HA90	Half	R-290	22 $\frac{1}{4}$ "	900 lb
CIM0836HA90	Half	R-290	30 $\frac{1}{4}$ "	900 lb
CIM1126FA90**	Full	R-290	22 $\frac{1}{4}$ "	1000 lb
CIM1446HA49	Half	R-449	48 $\frac{1}{4}$ "	1600 lb

REMOTE COOLED

CIM1446HR49	Half	R-449	48 $\frac{1}{4}$ "	1609 lb
CIM2046HR49	Half	R-449	48 $\frac{1}{4}$ "	1830 lb
CIM2046FR49	Full	R-449	48 $\frac{1}{4}$ "	1830 lb

*Ice production per 24 hours based on 70° Air/50°F Water **Not NSF

Slope Front Storage Bins

- Holds 344 lb to 854 lb of ice
- Pairs with top-mounted Ice-O-Matic ice makers
- Slope front design and top-hinged door
- Foam-insulated walls and polyethylene bin liner provides a sanitary, easy-to-clean interior surface
- Durable aluminum exterior
- 6" legs
- 2-year parts and labor warranty



	DIMENSIONS	STORAGE CAPACITY
B40	30" w x 31" d x 37 $\frac{1}{2}$ " h	344 lb
B42	22" w x 31" d x 50" h	351 lb
B55	30" w x 31" d x 50" h	510 lb
B110	48" w x 31" d x 50" h	854 lb



B55



CIMU220FA90



Undercounter Ice Machines

- Delivers reliable cube ice production with a compact, undercounter design
- Front-breathing, air-cooled system with built-in ice storage bin
- Corrosion-resistant stainless steel with nickel-plated evaporator plates
- R-290 refrigerant, 115V
- One-touch cleaning and an intuitive LED control display
- Harvest Assist technology helps maintain consistent ice production
- 3-year parts and labor warranty, 5-year parts on evaporator and compressor warranty, and 7-year parts and labor warranty on evaporator

FULL CUBE	WIDTH	ICE PRODUCTION*	STORAGE CAPACITY
CIMU220FA90**	24 $\frac{27}{50}$ "	220 lb	74 lb
CIMU300FA90	30 $\frac{17}{50}$ "	302 lb	112 lb
HALF CUBE			
CIMU220HA90**	24 $\frac{27}{50}$ "	220 lb	74 lb
CIMU300HA90	30 $\frac{17}{50}$ "	302 lb	112 lb

*Ice production per 24 hours based on 70° Air/50°F Water **ENERGY STAR*



Flake Ice Makers

- Produces flake-style ice ideal for preserving and displaying perishable foods
- Installs on a wide range of bins and dispensers
- Includes a heavy-duty gearbox, stainless steel evaporator assembly, and industrial-grade double roller bearings
- Water sensor eliminates low or no water failures and operates in adverse water conditions
- Built-in, non-contact ice detection fail safe automatic shutoff
- Load monitoring system constantly checks workload
- Air-Cooled models use R-290 refrigerant and Remote-Cooled models use R-449
- 3-year parts and labor warranty, 5-years parts warranty on compressor



Remote-cooled for flexible installation

MF1256A90



MF12306R49

AIR-COOLED	WIDTH	ICE PRODUCTION*
MF10500A90	21"	465 lb
MF10800A90	21"	790 lb
MF1256A90	21"	1045 lb
MF11506A90	21"	1377 lb



REMOTE-COOLED	WIDTH	ICE PRODUCTION*
MF11256R49	21"	1035 lb
MF11506R49	21"	1375 lb
MF12306R49	30"	2100 lb



*Ice production per 24 hours based on 70° Air/50°F Water



HEM0450A90



Engineered for ice demand.



GEM0450A90

Quartz Ice Makers

- Quartz chewable nugget ice cools beverages faster without diluting flavor
- Reduces water and electricity consumption compared to traditional cube ice makers
- Stainless steel evaporator and a heavy-duty gearbox
- Integrated load monitoring and water sensors
- Maintenance-free, industrial-grade double roller bearings
- Built-in, non-contact ice detection fail safe automatic shutoff
- Choose air-cooled or remote type condenser
- 3-year parts and labor warranty
- 5-year warranty on compressor

R-449 ICE MAKERS



R-290 ICE MAKERS



AIR-COOLED, R-290 REFRIGERANT	WIDTH	ICE PRODUCTION*
HEM0450A90	21"	365 lb
HEM0650A90	21"	610 lb
HEM0956A90	21"	800 lb
HEM1306A90	21"	1000 lb
REMOTE COOLED, R-449 REFRIGERANT		
HEM0650R49	21"	500 lb
HEM0956R49	21"	740 lb
HEM1309R49	21"	975 lb
HEM2006R49	30"	1500 lb

*Ice production per 24 hours based on 70° Air/50°F Water

Pearl Ice Makers

- Produces soft, chewable Pearl nugget ice
- Lowers water and energy consumption comparable to cube ice machines
- Heavy-duty gearbox and stainless steel evaporator
- SystemSafe load monitoring and an intelligent water sensor
- These modular continuous ice makers are compatible with a large variety of dispensers and bins
- 3-year parts and labor warranty on ice maker
- 5-year parts warranty on compressor



AIR-COOLED, R-290 REFRIGERANT	WIDTH	ICE PRODUCTION*
GEM0450A90	21"	416 lb
GEM0650A90	21"	700 lb
GEM0956A90	21"	928 lb
GEM1306A90	21"	1306 lb
REMOTE COOLED, R-449 REFRIGERANT		
GEM0650R49	21"	763 lb
GEM0956R49	21"	932 lb
GEM1309R49	21"	1830 lb
GEM2006R49	30"	1780 lb

*Ice production per 24 hours based on 70° Air/50°F Water



Heavy-Duty Restaurant Ranges

- All stainless steel front, sides, high shelf and riser
- 12" x 12" cast iron top grates with 32,000 BTU lift off burners
- 1" thick steel griddle plate, 20,000 BTU burners per 12" width
- 3 customized range top options
- 6" stainless steel landing ledge
- No tools removable shelf for easy cleaning
- Oven(s) feature porcelainized interior with 2 racks
- Temperature range from 250° to 500°F
- Natural gas or liquid propane
- 2-year limited parts and labor warranty



	WIDTH	BURNERS	GRIDDLES	OVENS	BTU
AR-6	36"	6	--	1	227,000
AR-10	60"	10	--	2	390,000
AR-36G	36"	--	36"	1	95,000
AR-36G-6B	72"	6	36"	2	322,000



AR-36G-6B
SHOWN W/OPTIONAL
CASTERS



AR-36G
SHOWN W/OPTIONAL
CASTERS

1" thick steel
griddle plate

Gas Ranges

- Stainless steel exterior with enamel interior
- Heavy-duty 12" x 12" removable cast iron top grates
- Oven temperature range between 175° to 550°F
- Standing pilot for open top burners
- Oven pilot with 100% safety shut off
- 2 adjustable chrome oven racks per section
- 3/4" NPT rear gas connection and regulator provided
- Available in Natural gas or LP gas
- 31"d x 57 1/2"h
- 1-year parts & labor warranty with option to purchase up to 5-year parts & labor warranty



AGR-6B



	WIDTH	BURNERS	OVENS	GRIDDLES
AGR-4B	24"	4	(1) 20"	--
AGR-6B	36"	6	(1) 26 1/2"	--
AGR-8B	48"	8	(2) 20"	--
AGR-10B	60"	10	(2) 26 1/2"	--
GRIDDLE TOP				
AGR-24G	24"	2	(1) 20"	24"
AGR-36G	36"	2	(1) 26 1/2"	36"
BURNERS W/ GRIDDLE RIGHT				
AGR-2B24GR	36"	2	(2) 20"	24"
AGR-4B36GR	60"	4	(2) 26 1/2"	36"
AGR-6B24GR	60"	6	(2) 26 1/2"	24"
BURNERS W/ GRIDDLE LEFT				
AGR-2B24GL	36"	2	(2) 26 1/2"	24"
BURNERS W/ RAISED GRIDDLE				
AGR-6B24RGB	60"	6	(2) 26 1/2"	24"

6" standard
casters



AGR-4B36GR

GARLAND

G-Series Gas Restaurant Ranges, Broilers & Cheese Melters

- Stainless steel front, sides and 5" deep front rail
- Stainless steel backguard with removable shelf
- 33,000 BTU Starfire® 2-piece cast-iron open top burners
- Griddle Tops feature 5/8" thick steel griddle plates and 1 H-style burner every 12" of width
- One-piece oven with porcelain interior
- Nickel-plated oven rack on 3-position removable oven rack guide
- Fast recovery snap-action modulating oven thermostat
- 6" stainless steel legs with adjustable feet
- Optional Infrared Salamander Broilers and Cheese Melters are available and sold separately

RANGES	WIDTH	BURNERS	OVENS	GRIDDLES	TOTAL BTU
G24-4L	23 3/8"	4	1 Space Saver	--	164,000
G24-2G12L	23 3/8"	2	1 Space Saver	12"	116,000
G24-G24L	23 3/8"	--	1 Space Saver	24"	68,000
G36-6R	35 1/2"	6	1 Standard	--	236,000
G36-4G12R	35 1/2"	4	1 Standard	12"	188,000
G36-2G24R	35 1/2"	2	1 Standard	24"	140,000
G36-G36R	35 1/2"	--	1 Standard	36"	92,000
G48-8LL	47 1/4"	8	2 Space Saver	--	328,000
G48-6G12LL	47 1/4"	6	2 Space Saver	12"	280,000
G48-4G24LL	47 1/4"	4	2 Space Saver	24"	232,000
G48-2G36LL	47 1/4"	2	2 Space Saver	36"	184,000
G48-G48LL	47 1/4"	--	2 Space Saver	48"	136,000
G60-10RR	59 1/8"	10	2 Standard	--	406,000
G60-8G12RR	59 1/8"	8	2 Standard	12"	358,000
G60-6G24RR	59 1/8"	6	2 Standard	24"	310,000
G60-4G36RR	59 1/8"	4	2 Standard	36"	262,000
G60-2G48RR	59 1/8"	2	2 Standard	48"	214,000
G60-G60RR	59 1/8"	--	2 Standard	59 1/2"	166,000
G60-6R24RR	59 1/8"	6	2 Standard	24" Raised	307,000

SALAMANDER BROILERS

GIR36	Mounts over G36 model ranges
GIR48	Mounts over G48 model ranges
GIR60	Mounts over G60 model ranges
GIR36C	Countertop, 34"w



CHEESE MELTERS

GIRCM36	Mounts over G36 model ranges
GIRCM48	Mounts over G48 model ranges
GIRCM60	Mounts over G60 model ranges
GIRCM36C	Countertop, 34"w

SunFire® X-Series Gas Restaurant Ranges

- 30,000 BTU 2-piece "Q" style donut burners
- Ergonomic split-grate design allows for effortless movement of pots and pans
- Porcelain hearth provides temperatures from 150° to 500°F
- Stainless steel exterior and backguard with removable shelf
- 33 1/2" d x 57" h

GARLAND



X	WIDTH	BURNERS	OVENS	GRIDDLES	TOTAL BTU
X24-4L	23 3/8"	4	1 Space Saver	--	145,000
X36-6R	35 1/8"	6	1 Standard	--	213,000
X36-2G24R	35 1/8"	2	1 Standard	--	129,000
X60-10RR	59 1/8"	10	2 Standard	--	366,000
X60-6G24RR	59 1/8"	6	2 Standard	24"	282,000
X60-6R24RR	59 1/8"	6	2 Standard	24", Raised	279,000



Split cast-iron top grates



G60-6R24RR



GIR36



GIRCM36

Space saver or standard ovens



X36-6R

Cook with confidence.



X60-6G24RR



Garland Cuisine Series Heavy-Duty Combination Top Ranges, Broilers & Cheese Melters

- Heavy-duty gas ranges with various top and base configurations, also available as a modular top
- Connect individually, a battery or an island suite
- Fully insulated oven provides precise temperatures from 150° to 500°F
- Stainless steel front, sides, front rail, stub back, legs and burner box
- Starfire 7" open burners in 12" lanes with 35,000 BTU per burner, 9" open burners in 18" lanes with 40,000 BTU per burner
- Hot Tops are available in Even-Heat or Front-Fired design and come in 12" or 18" widths
- 1 standard oven with a porcelain interior, a solid door and a keep-cool handle
- 36" w x 39 3/4" d x 43 3/4" h
- Optional Infrared Salamander Broilers and Cheese Melters available and sold separately



RANGES	BURNERS	GRIDDLES	HOT TOP	TOTAL BTU
C36-1R	--	36"	--	130,000
C36-2R	2 x 12"	24"	--	170,000
C36-3R	--	24"	12"	125,000
C36-4R	2 x 18"	18"	--	150,000
C36-5R	--	18"	18"	102,500
C36-6R	6 x 12"	--	--	250,000
C36-7R	4 x 18"	--	--	197,000
C36-8R	--	--	3 x 12"	115,000
C36-9R	--	--	2 x 18"	105,000
C36-10R	--	--	2 x 18"	115,000
C36-11R	--	--	2 x 18"	110,000
C36-12R	2 x 12"	--	2 x 12"	160,000
C36-13R	4 x 12"	--	12"	205,000
C36-14R	2 x 18"	--	18"	152,500
C36-17R	2 x 18"	--	18"	157,500

GARLAND



SALAMANDER BROILERS

- CIR36** Mounts over C36 Model Ranges
- CIR36C** Countertop, 34" w

CHEESE MELTERS

- CIRCM36** Mounts over C36 Model Ranges
- CIRCM36C** Countertop, 34" w

Precision. Power. Performance.

VULCAN

Endurance™ Gas Restaurant Ranges

- Fully MIG welded frame
- Stainless steel front, sides, back riser, lift-off high shelf and 6" adjustable legs
- (6) 30,000 BTU open top burners
- 1 standard oven with a solid door
- Extra deep pull-out crumb tray
- Oven thermostat adjusts from 250° to 500°F
- Rear gas connection and gas pressure regulator
- Natural gas or propane gas
- 2 oven racks with 4 rack positions
- 1-year limited parts and labor warranty

36S-6B 36" w x 34" d x 58" h



Lift-off burner heads



36S-6B
W/ OPTIONAL CASTERS



ER-6-G24 SHOWN W/
OPTIONAL CASTERS

IMPERIAL

Elements Series Gas Ranges

- High-output cast iron open burners with cast iron 12" x 12" grates
- Stainless steel front, backguard, shelf, landing edge and kick plate
- Aluminum sides, rear, top and door lining
- Chef depth oven cavity accommodates 18" x 26" sheet pans
- Includes 1 chrome oven rack
- Standard oven(s)
- 3" wide grease trough and removable grease can
- 6" legs with adjustable feet
- 34 1/4" d x 56 1/2" h

ER-6 36" w, 6 Burners, 1 Standard Oven, 203,000 BTU
ER-6-G24 60" w, 6 Burners, 24" Griddle, 2 Standard Ovens, 268,000 BTU

1/2" polished
steel griddle
plate



Turn up the heat.

4601DD
SHOWN W/ OPTIONAL
CASTERS



SOUTHBEND SINCE 1928

400 Ultimate Series Ranges

- Standard or wavy cast iron grates
- Heavy-duty counter balanced oven door
- Manual gas shut off valve for entire range
- Metal knobs
- High efficiency snap action oven thermostat
- Choice of electric oven base with gas top (Hybrid)
- Convection or standard oven(s) maintain 175° to 550°F
- All enameled coved oven with lift-out bottom
- 4" stainless steel front rail, stainless steel front and sides
- Factory installed regulator
- Standard 22 1/2" flue riser with heavy-duty shelf
- Optional spark ignition and flame failure
- Fully customizable, choose your burners and grates
- Standard ovens: 34" d x 59 1/2" h
- Convection ovens: 42 1/2" d x 59 1/2" h
- 6" stainless steel adjustable legs
- 1-year parts and labor warranty



	WIDTH	BURNERS	OVEN(S)	BTU
4361D	36"	6	1 Standard	243,000
4601DD	60"	10	2 Standard	420,000
4361A	36 1/2"	6	1 Convection	230,000
4365A	36 1/2"	5	1 Convection	211,000
4601AA	60 3/4"	10	2 Convection	394,000

Power your kitchen line.



S Series Restaurant Ranges

- Patented 28,000 BTU clog-free burners
- 35,000 BTU standard oven(s)
- Stainless steel front rail with closed, welded end caps and 6" adjustable legs
- Standard or convection oven(s) with black enamel interior
- Oven(s) maintain temperatures from 175° to 550°F
- Chrome knobs and door handle
- U burner and snap action thermostat
- 34" d x 59½" h



S60AA
SHOWN W/ OPTIONAL
CASTERS

	WIDTH	BURNERS	OVEN(S)	BTU
S36D	36"	6	1 Standard	203,000
S36A	36½"	6	1 Convection	203,000
S48DC	48½"	8	1 Standard, 1 Cabinet	259,000
S60AA	60¾"	10	2 Convection	350,000



Smart Touch Combi Ovens

- 10" smart touch screen maintains temperature and humidity
- Maintains temperature range from 86° to 500°F
- 8 fan speed balance reverse for even cooking
- Holds 18" x 13" or 12" x 20" pans
- Sub-divided heating system
- Smart touch rack timing for mixed load batch cooking
- USB storage
- Automatic cleaning, shut down and unlock when finished
- Includes 3M water filter system standard
- Certified training and installation are available upon request at additional cost
- Can use non-proprietary liquid professional Combi cleaners
- 1-year parts & labor warranty, with option to purchase up to 5-year parts & labor warranty

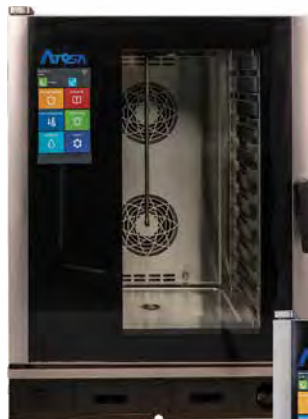

AEC-101IE

Includes cabinet
monitoring &
multi-stage
programming

31" w x 34½" d	CAPACITY	HEIGHT
AEC-051IE	(5) 18" x 13" or 12" x 20" Pans	28"
AEC-071IE	(7) 18" x 13" or 12" x 20" Pans	35"
AEC-101IE	(10) 18" x 13" or 12" x 20" Pans	41½"

36" w x 42½" d	CAPACITY	HEIGHT
AEC-062IE	(6) 18" x 13" or 12" x 20"	36½"
AEC-102IE	(10) 18" x 13" or 12" x 20" Pans	48½"



AEC-051IE



AEC-062IE





102BE

Shown On
Optional Stand



Invoq Series Electric Combi Ovens

- ClimateControl technology manages heat and humidity
- Intuitive 7" touchscreen
- SmartChef controls and MenuPlanner features
- Fast, 3-second boot up
- Space-saving stackable design
- Automated tablet-based cleaning system
- Boiler based or boilerless designs
- 1 glass door
- 208/240V

BOILER BASED	CAPACITY	DIMENSIONS
62BE	7 Pans	42 $\frac{3}{8}$ "w x 40 $\frac{1}{2}$ "d x 33 $\frac{1}{2}$ "h
102BE	10 Pans	43 $\frac{3}{8}$ "w x 49 $\frac{1}{8}$ "d x 47 $\frac{3}{8}$ "h
202BE	20 Pans	42 $\frac{3}{8}$ "w x 41 $\frac{1}{8}$ "d x 68 $\frac{1}{8}$ "h
BOILERLESS		
62BLE	7 Pans	42 $\frac{3}{8}$ "w x 40 $\frac{1}{2}$ "d x 33 $\frac{1}{2}$ "h
102BLE	10 Pans	43 $\frac{3}{8}$ "w x 49 $\frac{1}{8}$ "d x 47 $\frac{3}{8}$ "h
202BLE	20 Pans	42 $\frac{3}{8}$ "w x 41 $\frac{1}{8}$ "d x 68 $\frac{1}{8}$ "h



Mark V Full Size Electric Convection Ovens

- Oven compartment has porcelainized stainless steel liner
- Dependent doors with dual pane thermal glass windows, porcelain handle and interior lights
- Single inlet blower wheel powered by a two-speed, 1/2 hp motor with thermal overload protection
- 3 tubular heaters
- Solid state controls with temperature range of 200° to 500°F
- 60-minute digital timer
- Holds (5) 18" x 26 sheet pans per section
- 38 $\frac{1}{4}$ "w x 36 $\frac{1}{4}$ "d
- Full size design with touchscreen controls
- 208V
- 3-year parts and 2-year labor warranty, 5-year limited oven door warranty



MARK V-100 SGL

SHOWN ON
OPTIONAL CASTERS



MARK V-200 DBL

SHOWN ON
OPTIONAL CASTERS

SINGLE (57" h w/ 25" legs)
MARK V-100 SGL Standard Depth
MARK V-200 SGL Bakery Depth

DOUBLE (70 $\frac{1}{2}$ " w/ 6" legs)
MARK V-100 DBL Standard Depth
MARK V-200 DBL Bakery Depth



Stainless steel
front, top,
doors & sides

THE KING OF COMPACT

The world's smallest, smartest combi oven.
mini pro combi oven

AI-Driven Optical Product Recognition | Solid-to-Liquid Cleaning System
Available in Black or Silver | Only 19.6" Wide



6.06



6.10



10.10



6.10/6.10



6.10/10.10

CONVOTHERM®



ConvoSmoke
Integrated, no wires,
hot and cold smoke

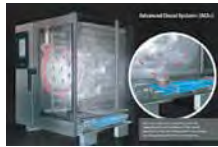

Advanced Closed System
Greater cavity control,
recovery & efficiency



UL Certified Ventless
Electric tabletop and
mini pro - no hood!



HygieniCare
Anti-bacterial coating on
touch surfaces



Disappearing Door
Space saving, productivity
and safety enhancing



ConvoGrill
On board grease
management



Press&Go
Icon based customized
to operator menu



Hands-Free Cleaning
Certified for unattended
cleaning



ConvoSense
AI-Driven Optical
Cooking



Easy Service
Five service hatches for
easy access

Manufacturers of World-Class Combi Ovens Since 1976

mini pro: Electric, Spritzer



6.06 mini 6.10 mini 10.10 mini

maxx pro (tabletop & floor-standing): Electric, Gas, Boiler, Spritzer



6.10 maxx pro 6.20 maxx pro 10.10 maxx pro 10.20 maxx pro



20.10 maxx pro



20.20 maxx pro



Majestic Gas Convection Ovens

- Stainless steel front, top and sides
- Standard and Bakery Depth
- 50/50 dependent glass doors with a 135° door swing
- Holds 18" x 26" pans
- Maintains temperatures from 200° to 500°F
- Manual controls
- ½ hp, 2-speed fan convection system
- 5 chrome racks with 12 position chrome rack guides
- Single or double units come with either 6" legs or casters
- 40" w
- 2-year limited parts and labor warranty
- Made in the USA



MSD DBL

Porcelainized oven interior for easy cleaning

Even heat.
Exceptional results.

SINGLE DECK

MSD Standard Depth, 38 $\frac{3}{4}$ "d x 59 $\frac{1}{2}$ "h, 70,000 BTU
M Bakery Depth, 46 $\frac{1}{2}$ "d x 61 $\frac{1}{2}$ "h, 90,000 BTU

DOUBLE DECK

MSD DBL Standard Depth, 38 $\frac{3}{4}$ "d x 75 $\frac{1}{2}$ "h, 140,000 BTU
M DBL Bakery Depth, 46 $\frac{1}{2}$ "d x 76 $\frac{1}{2}$ "h, 180,000 BTU

Premium Series Gas Convection Ovens

- Standard depth or bakery depth
- Stainless steel front, top, sides and back
- Dual pane thermal glass window in stainless steel door frames
- Full angle-iron frame
- Dependent glass doors
- Touchscreen controls
- Dual flow gas system combines direct and indirect heat
- Solid state thermostat with temperature range of 200° to 500°F
- Interior oven lights
- Full-size designs hold (5) full size sheet pans or (10) 12" x 20" x 2 $\frac{1}{2}$ " steam table pans per section
- Half-size design holds (5) ½ size pans or (5) hotel pans per section
- 3-year parts and 2-year labor warranty, 5-year limited oven door warranty
- Made in the USA

FULL-SIZE (38 $\frac{3}{4}$ "w x 36 $\frac{1}{2}$ "d)

5 Chrome-Plated Racks, 11 Rack Positions per Section

DFG-100 SGL Single, Standard Depth, 50,000 BTU, 70 $\frac{1}{2}$ "h w/ 6" Legs
DFG-100 DBL Double, Standard Depth, 100,000 BTU, 57 $\frac{1}{2}$ "h w/ 25" Legs
DFG-200 SGL Single, Bakery Depth, 60,000 BTU, 70 $\frac{1}{2}$ "h w/ 6" Legs
DFG-200 DBL Double, Bakery Depth, 120,000 BTU, 57 $\frac{1}{2}$ "h w/ 25" Legs

HALF-SIZE (30 $\frac{1}{2}$ "w x 25 $\frac{1}{2}$ "d)

5 Chrome-Plated Racks, 9 Rack Positions per Section

DFG-50 SGL Single, Standard Depth, 27,500 BTU, 35 $\frac{1}{2}$ "h
DFG-50 DBL Double, Standard Depth, (2) 27,500 BTU, (2) 35 $\frac{1}{2}$ "h



DFG-100 SGL

SHOWN ON
OPTIONAL STAND



BLODGETT



DFG-50 SGL

SHOWN ON
OPTIONAL STAND

BLODGETT

ImVection Ovens

- Combines convection and impingement in a single unit
- Independently controlled chambers
- Each chamber holds a 16" pizza or 1/2 size pan
- Ventless design with catalytic converters eliminates the need for a dedicated hood
- Constructed of stainless steel with stainless steel cooking chambers
- Top mounted, 7" capacitive touchscreen controls
- Variable speed blowers
- Adjustable feet
- Glass swing door(s)
- 24" w x 37" d
- 208-240V
- Maintains temperature from 300° to 525°F
- 1-year parts and labor warranty



IMV-4E
SHOWN ON OPTIONAL STAND WITH CASTERS



IMV-3E 3 Ovens, 45 1/2" h w/ 6" legs
IMV-4E 4 Ovens, 48 1/2" h w/ 6" legs

Advanced air flow system provides consistent heat



IMPERIAL



SHOWN W/ OPTIONAL CASTERS

Elements Series Gas Convection Oven

- Thermostatic control maintains temperature from 150° to 500°F
- Porcelainized oven interior
- Stainless steel solid doors and aluminum side panels
- 10 rack positions, 3 oven racks included
- 2 solid, 50/50 doors swing open to 130°
- 1-speed, 1/2 hp fan motor for high production cooking and delicate baking
- Single deck, standard oven depth
- 35,000 BTU

ECV-1 38" w x 40" d x 34" h

SOUTHBEND Since 1932



PCG50S/SD-PRO
SHOWN W/ OPTIONAL CASTERS



PCG140S/TD-PRO
SHOWN W/ OPTIONAL CASTERS

SOUTHBEND Since 1932



PCE75S/SD-PRO-V
SHOWN W/ OPTIONAL CASTERS



PCE22B/TD
SHOWN W/ OPTIONAL CASTERS

Platinum Pro Series Gas Convection Ovens



- Your choice of standard control options or touchscreen controls with programmable modes
- Standard with wired probes and wireless probes available as an option with touchscreen models
- Patented non-clog in-shot burner system and two-speed fan
- Stainless steel front, top and sides
- Coved, fastener-free porcelain interior
- 38" w x 38 1/2" d
- Single or double deck
- Glass 60/40 dependent doors
- Oven(s) maintain temperature from 140° to 500°F
- 1-year limited parts and labor warranty

PCG50S/SD-PRO Single Deck, 55" h, 50,000 BTU
PCG140S/TD-PRO Double Deck, 64 1/2" h, 140,000 BTU

Platinum Pro Series Electric Convection Ovens



- Powerful electric convection oven
- Solid state thermostat or touchscreen controls with manual, recipe or rack modes
- Hinged control panel
- Stainless steel front, sides and top with 60/40 dependent glass doors
- 5 interior shelves per oven
- Maintains temperatures from 140° to 500°F
- 208/220/240V
- 38" w
- 1-year limited parts and labor warranty

PCE75S/SD-PRO-V† Single Deck, Ventless, 38 1/2" d x 55" h
PCE22B/TD Double Deck, 45" d x 68 1/2" h
†ENERGY STAR®



Advanced airflow for total control.

Turbofan Convection Ovens



- Bi-directional reversing fan system circulates air
- Multi-level steam injection develops crisp crusts
- Available with digital or One-Touch controls
- Digital controls store up to 30 multi-stage recipes
- Constructed of stainless steel with porcelain enameled oven chamber
- Stands hold (12) 1/2 size or (6) full size sheet pans
- Ventless hoods and proofer are 110-120V
- 3" casters included

W/ HALTON VENTLESS CONDENSING HOODS

E33D5/P10/VH33

Half Size Stacked w/ Proofer, Proofer Holds (10) 1/2 Size or Full Size Pans, Oven Holds (5) Full Size Pans, Digital Oven, Dial Proofer, 24 3/4" w x 37 1/4" d x 79 1/2" h, 208-240V

E32T5/SK32/VH32†

Full Size on Stainless Steel Stand, Oven Holds (5) Full Size Pans, One-Touch Touchscreen, 29 1/4" w x 42 3/4" d x 76 1/2" h, 110-120V

E35D6/P85M12/VH35-26

Full Size Stacked w/ Proofer, Proofer Holds (24) 1/2 Size or (12) Full Size Sheet Pans, Oven Holds (12) Full Size Pans, Digital Oven, Dial Proofer, 36 1/2" w x 42 3/4" d x 92 3/4" h, 208/220-240V

W/O HOOD

E31D4/SK2731U*

Half Size on Stainless Steel Stand, Holds (4) 1/2 Size Sheet Pans, Digital, 31 1/2" w x 26 1/2" d x 59 1/4" h, 208/220-240V

*Only cETLus, NSF
†ENERGY STAR*



Independent doors with thermal glass windows



Gas Convection Oven

- Single deck
- 120,000 BTU
- Stainless steel front, sides, top and painted legs
- Solid state controls maintain temperatures from 150° to 500°F
- 1/2 hp 2-speed fan
- Includes 5 nickel-plated oven racks adjustable to 11 guide positions
- Oven cool switch allows for rapid cool down between batches
- 1-year limited parts and labor warranty



SHOWN W/
OPTIONAL CASTERS



SG4 40" w x 42 1/4" d x 54 3/4" h



Convection Ovens

- Stainless steel front, sides, doors and top
- 5 nickel plated oven racks
- Gas models feature (1) 50,000 BTU burner per section
- Solid state temperature controls from 150° to 500°F
- Independent doors with double pane windows
- Single deck
- 1-year parts and labor warranty



VC4GD

GAS

VC4GD* 40" w x 42 1/4" d x 54 3/4" h

VC5GD 40" w x 39 1/4" d x 54" h

ELECTRIC

VC4ED 40" w x 42 1/4" d x 54 3/4" h

VC5ED 40" w x 39 1/4" d x 54" h

*Not cCSA Gas

GAS



ELECTRIC





Jet Air Convection Oven

- Holds (12) 18" x 26" pans on 3½" shelf spacing
- "Jet Air" bakes faster and more evenly with patented reversing fan system
- Steam injection creates crisp, golden-brown crusts
- 99 programmable recipes, 8-stage baking
- Stainless steel construction with brightly lit interior
- Digital reminder timer, temperature and touch screen controls
- Full view, heat reflective thermal glass doors with magnetic latches
- Temperature range to a maximum of 500°F
- Locking casters
- 208-240V
- 1-year labor warranty, 2-year parts warranty
- Made in USA



JAI2SL 38¾" w x 37¾" d x 73" h



Gas Convection Ovens

- Powerful direct-fired gas burners and a dual-speed fan motor
- Wide temperature range of 150° to 500°F
- Stainless steel front and sides
- Dual pane, thermo glass windows with independent operating doors
- 60 minute electric timer with bell
- ½ hp fan motor with dual speed control
- 5 heavy-duty chrome plated racks per section
- Automatic ignition system
- Micro switch for complete shut off once door is opened
- Porcelainized interior is easy to clean
- 4 swivel casters with brakes
- 38" w x 42½" d
- 1-year parts and labor warranty



SE-C01D



SE-C01D Single Deck, 57¼" h, 60,000 BTU
SE-C02D Double Deck, 67¾" h, 120,000 BTU

Stackable design maximizes cooking capacity per square foot



SE-C02D

Circle Air Rotating Oven

- 100% uniform baking with a removable rotating rack system and Jet Air reversing fan system with variable air speeds
- Shot and pulse steam injection with Power Vent moisture evacuation system
- Touchscreen controls offer 8-stage programmable baking
- Stainless steel construction
- Dependent stainless steel doors with glass inserts for easy viewing and monitoring
- 15-minute preheat
- Maintains temperatures up to 500°F
- 208-240V
- 2-year parts and 1-year labor warranty
- Made in USA



CA6X 43¾" w x 55¾" d x 36¾" h

Shown on optional CA6B Stainless Steel Stand



PCG50S/SD SHOWN W/ OPTIONAL CASTERS



PCG100S/SD SHOWN W/ OPTIONAL CASTERS

Platinum Series Gas Convection Ovens

- Both Standard and Bakery Depth models have 5 plated wire racks
- Stainless steel front, sides and top
- Glass 60/40 dependent doors
- 140° to 500°F temperature range
- 38" w x 38½" d
- Single deck or double deck
- Solid state thermostat
- 1-year limited parts and labor warranty

SINGLE DECK	HEIGHT	BTU
PCG50S/SD	55"	50,000
PCG70S/SD	55"	70,000
DOUBLE DECK		
PCG100S/SD	64¾"	100,000
PCG140S/SD	64¾"	140,000



Super Deck Y Series Gas Pizza Oven

- Stainless steel front, sides, top and back
- 2" thick fibrament brick-lined decks
- Adjustable heat control dampers assure balanced top and bottom temperatures
- Temperature range from 300° to 650°F
- Fully insulated
- 120,000 BTU per deck
- Natural or LP gas
- Double deck units also available
- 78" w x 43" d x 55½" h
- 1-year parts and labor warranty

Y-600 Single Deck



SHOWN W/OPTIONAL
CASTERS

High-quality, commercial results.



Love at first slice.

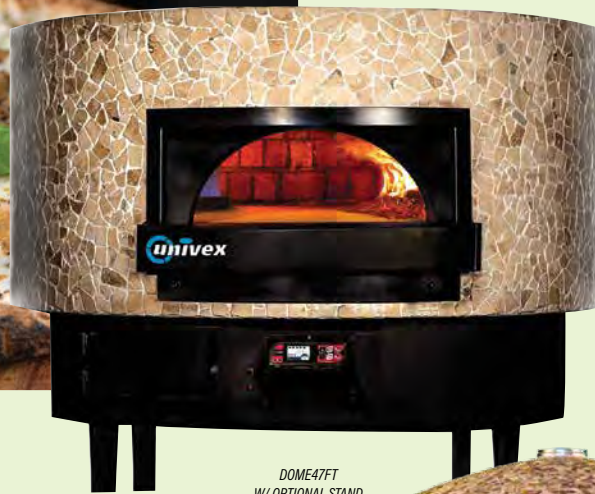

Rotating stone
hearth deck for
even cooking

DOME47FT
W/ OPTIONAL STAND



DOME47RT
W/ OPTIONAL STAND

Rotating Deck Stone Hearth Dome Ovens

- Features high-alumina refractory brick construction and an iron door
- Combines a gas burner with independent electric floor heat
- Smart Chef intuitive touchscreen controls manage deck rotation, temperature and cooking programs
- Retains heat overnight to reduce preheating time and energy consumption
- Maintains temperatures up to 1000°F
- Flat top or dome top available
- DOME47 models feature a 47" cooking chamber with 39½" cooking surface
- DOME59 models feature a 59" cooking chamber with 55" cooking surface
- 208-240V
- 1-year on-site parts and labor warranty

	TOP	PIZZA CAPACITY	DIMENSIONS
DOME47RT	Dome	6	65" dia x 72½" h
DOME59RT	Dome	14	76¾" dia x 72½" h
DOME47FT	Flat	6	80¾" w x 65" d x 72½" h
DOME59FT	Flat	14	92½" w x 76¾" d x 72½" h



EQUIPMENT



Modular Pizza Ovens

- Engineered for baking pizza or roasting
- Ceramic clay hearthstones and 3 oven deck lights
- IQ Control Panel™ automates temperature recovery, guards against component failure and enables rapid pre-heating
- Deck-specific vent levers offer precise humidity control
- Holds 14", 16", 18" or 20" pizzas or 18" x 26" pans per deck
- 3 decks with pull up glass doors
- Maintains temperatures up to 752°F
- 5½" casters
- Made of stainless steel
- 208/240V
- 2-years parts warranty, 1-year labor warranty



	DECK SIZE	PIZZA SIZE	DIMENSIONS
PM 733ED	42" x 28"	14"	58¾" w x 35¾" d x 75½" h
PM 833ED	48" x 32"	16"	65¾" w x 40¾" d x 75½" h
PM 933ED	54" x 36"	18"	71¾" w x 44¾" d x 75½" h
PM 1133ED	63" x 42"	20"	80¾" w x 50¾" d x 75½" h



Jet Air PIZ Series Pizza Oven

- Preheats in 15 minutes and bakes (3) 18" pizzas in 5-6 minutes
- Jet air patented reversing fan system for even baking
- Temperature control up to 600°F
- Stainless steel exterior and interior with 3 nickel-plated perforated baking decks
- Digital controls
- 3 ovens with easy open and close drop down doors with full view thermal glass
- ¾ hp
- 120V/208-240V
- 2-year parts warranty and 1-year labor warranty

PIZ3 35½" w x 40¾" d x 34¼" h



MB Series Brick Ovens

- Engineered to bake a crisp, brick-oven style pizza
- Arched refractory brick-lined ceiling and 2" thick deck
- Innovative air chamber eliminates hotspots without rotating pies
- Unfinished aluminized steel exterior
- Flat top
- 62½" w x 44¼" d
- Bakes 18" pizzas
- Thermostatic controls
- Maintains temperatures from 300° to 650°F
- Also available in propane
- 18-months parts and 1-year labor warranty



MB42 (1) 36" x 42" Cooking Surface, Bakes (4) 18" Pies, 60¼" h, 95,000 BTU
MB42 STACKED (2) 36" x 42" Cooking Surfaces, Bakes (8) 18" Pies, 71¼" h, (2) 95,000 BTU

High Temperature Ventless Pizza Oven

- High temperature baking at 600°F
- Ventless construction for hood-free use
- Capacity (3) 18" pizzas
- Can be stacked up to 2 high
- Bidirectional Jet Air Fan System delivers consistent, even baking
- Simple to operate touchscreen control with independent deck timers
- Perfect for fresh and parbaked crusts
- Directly bake on perforated nickel plated decks
- 208-240V, 1 Phase

RP03 27½" w x 36¾" d x 28½" h



Gas Pizza Deck Ovens

- Fully welded angle iron frame
- 1 Ultra Rokite stone deck per oven
- Stainless steel front, top, sides, back and legs
- Maintains temperatures from 300° to 650°F
- Heavy chrome plate tubular steel door handle
- Aluminized steel combustion chamber and baking compartment
- 60¾" w x 46½" d
- 2-year parts and 1-year labor warranty, 5-year limited oven door warranty
- Made in the USA



1048 SINGLE 57" h, 85,000 BTU
1048 DOUBLE 66¾" h, 170,000 BTU

Electric Ventless Conveyor Ovens

- The largest ventless conveyor oven on the market
- Certified ventless design allows for installation without a Type I or II ventilation hood
- Advanced air impingement technology bakes up to 30% faster than standard conveyor ovens
- Stackable configuration
- Patented energy management system
- Stainless steel construction
- 26" x 65 $\frac{1}{4}$ " long conveyor belt(s)
- 208/240V
- Maintains temperatures from 325° to 600°F
- 65 $\frac{1}{2}$ "w x 49 $\frac{1}{4}$ "d
- 2-year parts and labor warranty

PS638E-V-1 Single, 41 $\frac{1}{8}$ "h
PS638E-V-2 Double, 51 $\frac{1}{4}$ "h



Cool Skin safety feature maintains an external surface temperature below 120°F



PS638E-V-2



Fast-track delicious flavors.

LongWave Infrared Conveyor Ovens

- Utilizes top and bottom infrared elements for rapid cooking
- Consolidates baking, searing, broiling and roasting into 1 unit
- "Cool Skin" design
- Stainless steel exterior with insulated sides
- Independently-controlled microprocessor with 15 presets, time/date clock, standby mode and self-cleaning cycle
- Stackable up to 3 high
- Each oven includes 5" extension trays
- Maintains temperatures from 300° to 1200°F
- 208/240V
- 48 $\frac{3}{8}$ "w x 31" d
- 2-year parts and labor warranty

LW26-1 Single, 21 $\frac{1}{8}$ "h
LW26-2 Double, 37 $\frac{3}{8}$ "h
LW26-3 Triple, 55 $\frac{1}{8}$ "h



LongWave



LW26-1



PS540G-3

Gas Impingement Conveyor Ovens

- Impingement PLUS—low oven profile and dual air return
- Patented Jet Sweep impingement process delivers faster cooking at lower temperatures
- Independently-controlled microprocessor controls bake time, conveyor speed and heating zones
- Stainless steel front, sides, top and interior
- Single, double or triple stack design
- 80" w x 56 $\frac{3}{8}$ " d
- 208/240V
- Oven(s) maintain temperatures from 300° to 600°F
- 32" w x 76 $\frac{1}{2}$ " long conveyor belt(s)
- 2-year parts and labor warranty

PS540G-1 Single, 47 $\frac{1}{8}$ "h
PS540G-2 Double, 60 $\frac{3}{8}$ "h
PS540G-3 Triple, 83 $\frac{1}{8}$ "h



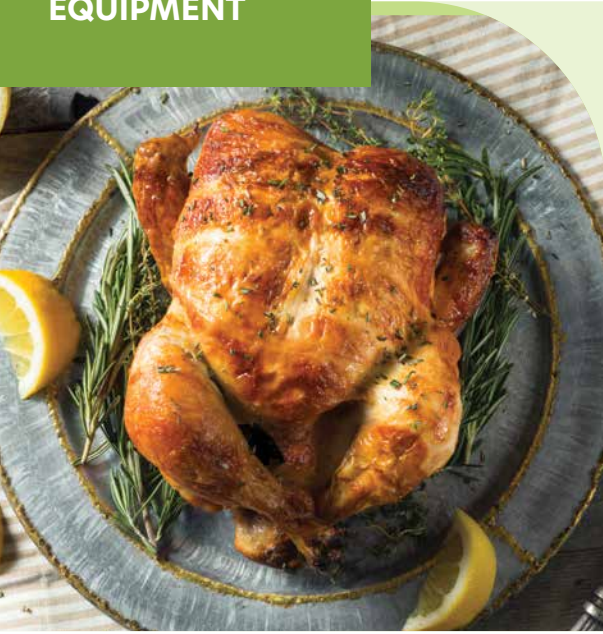

HotLogix Aluminum Heated Cabinets

- Bottom-mounted removable heating unit (models with humidity also have water reservoir)
- Recessed manual dial controls for temperature settings
- Dial controls for humidity settings (HL4-14)
- Single-pane tempered glass door set in extruded aluminum frame
- Cabinets come with fixed universal wire slides
- Holds 18" x 26" pans
- 5" swivel casters



NON-INSULATED (29½"d x 24¼"w)

HL1-14 Holding Cabinet, Holds 14 Pans, 58½"h

INSULATED (31½"d x 26½"w)

HL3-18 Holding Cabinet, Holds 18 Pans, 70½"h

HL4-14 Humidified Holding Cabinet, Holds 14 Pans, 58½"h

HL3-18



Maintain and lock in the heat.



Cook & Hold Oven

- Cooks, holds, and rethermalizes in a single unit
- Built with a 20 gauge stainless steel interior and exterior on an integrated steel frame
- Cooking temperatures up to 350°F
- Holding temperatures up to 250°F
- Low-speed fan ensures even heat distribution
- Digital LED display and knob-style controls can store 9 custom programs
- 208/240V
- 5" casters
- 27¼"w x 36"d x 34"h
- 1-year limited parts and labor warranty, 10-year parts warranty on heating elements

VCH5 Holds (5) 18" x 26" or (10) 12" x 20" Pans



Top-mounted electronic control with a digital display for ease of use



Holding & Transport Cabinet

- Stainless steel exterior and interior with a fully insulated cabinet
- Maintains temperatures up to 190°F with a forced-air blower
- Includes 5 pairs of universal tray slides adjustable on ½" centers
- Moves easily on 5" casters, 2 rigid and 2 swivel with locks
- 120V, 1500W
- 27¼"w x 33¼"d x 30½"h
- 1-year limited parts and labor warranty, 10-year parts warranty on heating elements

VBP5ES Holds and transports (5) 18" x 26" or (10) 12" x 20" Pans

Moves easily on 5" casters.



Non-Insulated Holding & Transport Cabinet

- Features a heavy-duty 20 gauge polished stainless steel cabinet
- Maintains temperatures up to 190°F with a top-mounted dial thermostat
- Blower and air tunnel system
- Full-size, glass door with field-reversible hinges
- Includes (4) 5" casters, 2 swivel with locks, 2 rigid
- 120V
- 25¼"w x 30¼"d x 45"h
- 1-year parts and labor warranty and 10-year parts warranty on heating elements

VHFA9 Holds (9) 18" x 26" or (18) 12" x 20" Pans



Rise & shine.



C5® 1 Series Non-Insulated Heated Holding & Proofing Cabinet

- Dual proofing and holding design
- Universal slides accommodate (18) 18" x 26" pans or (34) 12" x 20" x 2½" pans
- Full height, clear polycarbonate door
- Removable heat module
- Constructed of durable aluminum
- Smooth polymer drip trough with catch pan
- Easy-to-read digital thermometer, recessed analog control dials, master on/off switch and power indicator lights
- Holding and combination module maintains temperature from 80° to 190°F
- Proofing module maintains temperature from 80° to 120°F
- (4) 5" casters, 2 with brakes
- 1-year limited warranty

C519-CFC-U 25½" w x 30¼" d x 69¾" h



C5® 9 Series Controlled Humidity Heated Holding & Proofing Cabinet

- Full height design
- Holds up to (18) 18" x 26" sheet pans or (34) 12" x 20" x 2½" pans
- Intuitive touchscreen with menu presets and programmable timers
- Stainless steel construction with high-density insulation
- Solid double panel, insulated dutch-style doors with 4 built-in polymer handles
- Universal ¼" wire slides
- Convection airflow
- Maintains temperature control from 90° to 200°F
- (4) 5" casters
- 1-year limited warranty

C599-SDS-U 30" w x 36¾" d x 74¾" h



C5® 4 Series Insulation Armour® Plus Heated Holding Cabinet

- Full-height, stainless steel cabinet holds food safely up to 200°F
- Universal slides adjustable on 1½" increments
- Features Insulation Armour Plus™ foamed-in-place polyurethane polymer panels
- Solid, insulated dutch style doors with a red exterior
- Molded in handles that act as a full body bumper
- Thermostatic controls are mounted at the top of the cabinet
- Holds (16) 18" x 26" pans or (32) 12" x 20" x 2½" steam table pans
- (4) 5" casters, 2 with brakes
- 1-year limited warranty

C549-ASDS-U 30" w x 33" d x 69½" h



User-friendly, top mounted controls



Fully insulated cabinet maintains safe holding temperatures



C539-CFC-U



C539-HDS-U

C5® 3 Series Heated Cabinets with Insulation Armour®

- Red durable polymer Insulation Armour® resists dents and stains and stays cool to the touch
- Universal adjustable slides on 1½" increments
- Holds (18) 18" x 26" or (34) 12" x 20" x 2½" Pans
- (4) 5" casters
- 27½" w x 31½" d x 71" h

C539-CFC-U Holding & Proofing, 1 Clear Glass Door
C539-HDS-U Holding, 2 Solid Dutch Doors

Insulated Heated Cabinets

- Stainless steel exterior and interior
- Heating mode with adjustable temperature settings between 85° to 207°F
- Easy to read LED display
- Tempered glass door, field reversible
- Fully insulated cabinet with environmentally friendly foaming material prevents heat loss, provides energy savings and environmental protection
- Integrated slides and removable control drawer for easy cleaning
- 4 casters standard, 2 locking, 2 swivel
- 10' power cord
- 1-year parts and labor warranty with the option to purchase up to 5-year parts & labor warranty



ATHC-9ES Holds (9) 18" x 26" Pans
ATHC-18ES Holds (18) 18" x 26" Pans



ATHC-9ES



ATHC-18ES

Insulated Economy Warming & Holding Cabinets

- Stainless steel exterior and interior
- Heating mode with adjustable temperature settings between 90° to 205°F
- Easy to read LED display
- Transparent clear polycarbonate door with 90° stay open feature for loading of product
- Fully insulated cabinet with environmentally friendly foaming material prevents heat loss, provides energy savings and environmental protection
- Integrated slides and removable control drawer for easy cleaning
- Field reversible door
- 10' power cord
- 4 casters standard, 2 locking, 2 swivel
- 1-year parts and labor warranty with the option to purchase up to 5-year parts & labor warranty

ATWC 12 Holds (12) 18" x 26" Pans
ATWC 24 Holds (24) 18" x 26" Pans



ATWC-12



ATWC-24



Heat that holds.

Vision Series Self-Serve Heated Cases

- Holds products at grab-and-go temperatures up to 160°F
- Stainless steel exterior, interior and shelves
- Black powder coated frame
- Tempered glass ends and LED top lighting
- 4 independently controlled shelves can be adjusted flat or slanted at 10°
- Adjustable leg levelers
- Easy front access digital temperature controls
- 208/240V
- 33"d x 78"h

VHSS2478S 24"w
VHSS3678S 36"w
VHSS4878S 48"w



VHSS3678S

VICTORY

Ultraspec Reach-In Warming Cabinet

- Maintains temperatures from 80° to 180°F
- Stainless steel exterior and interior
- 20 gauge stainless steel door with cam-lift hinges and stay-open feature
- Delivers even heat with bottom-mounted elements and an external blower
- Features a full electronic control with touchpoint interface and manager's lockout
- One-piece, snap-in magnetic gasket for a secure door seal
- 3 silver freeze wire shelves
- 7-year parts and labor, 2-years on magnetic door gaskets, lifetime warranty on handles & hinges

HS-ID-1 26½"w x 34¾"d x 84½"h



Adjustable humidity control vent

M3 Series Glass Door Heated Cabinet

- Insulated mobile cabinet holds prepared food at safe temperatures
- 5 universal tray slides hold 18" x 26", 14" x 18" or 12" x 20" pans
- Digital control holds cabinet temperatures from 140° to 180°F
- Stainless steel interior and exterior with high-density polyurethane insulation
- Ducted fan air distribution system
- 1 stainless steel hinged door with glass window and LED interior lighting
- 4" swivel casters
- 115V
- Made in USA
- 3-year parts and labor warranty

M3H24-1-G-TS 28¾" w x 30¾" d x 78" h



Cleveland

Electric MVP Tilting Skillet

- Countertop design, compact footprint, 10-gallon capacity
- Type 304 stainless steel construction with #4 finish
- Bead-blast textured cooking surface reduces sticking
- Precision temperature up to 425°F for delicate sauces to hard sears
- Spring assist cover for smooth, effortless lifting
- Sanitary base mounting for clean tabletop installation
- Choose your control: classic easyDial or 7" easyTouch with Press & Go Recipes and sous vide mode
- IPX6 water-rated console (easyTouch model)
- 26" w x 34" d x 30½" h



SET10 10 Gallon



PowerPan™ Series Gas Tilting Skillets

- Ultra-efficient power burner delivers fast, even heat distribution
- Patented Forced-Air Gas Combustion System with automatic ignition
- Dual power settings for superior heat-up and recovery
 - SGL-30-T1: 90,000 & 125,000 BTU
 - SGL-40-T1: 160,000 & 200,000 BTU
- 5/8" stainless steel clad cooking surface, bead-blasted to resist sticking and warping
- Easy manual hand tilt with enclosed lubricated gearbox (power tilt optional)
- Choose your control: classic easyDial or 7" easyTouch with Press & Go Recipes and sous vide mode
- Low 35" rim height for comfortable operation and cleaning
- 41" d x 39" h

Cleveland



SGL-30T-1 30 Gallon, 39½" w
SGL-40T-1 40 Gallon, 51½" w



SGL-30T-1

PowerPan™ Series Electric Tilting Skillets

- Durable 12-gauge, 304 stainless steel pan construction
- 5/8" stainless steel cooking surface with bead-blasted finish to resist sticking and warping
- Low 35" rim height for comfortable operation and cleaning
- Easy-to-turn manual hand tilt with enclosed lubricated gearbox (power tilt optional)
- Open base design for easy cleaning and maintenance
- Spring-assist cover with full-width handle and vent
- 40" d x 39" h

SEL-30-T1 30 Gallon, 36" w
SEL-40-T1 40 Gallon, 48" w

Cleveland



SEL-30-T1

Low 35" rim height

Efficiency in motion.



Cucimix Electric Tilting Braising Pan with Mixer



- Constructed of stainless steel
- Automated mixing device with PTFE wall scraper prevents scorching and eliminates manual stirring
- Electronic control with a 7" touchscreen
- Precise temperature control from 78° to 428°F
- Can cook with basin tilted up to 15°
- Heated by armored INCOLOY-800 heating elements and a 3-zone wall system
- USB connection to download HACCP data, update the software and load cooking programs
- Option to cook in manual mode or program mode
- 34¾" w x 30¼" d x 46¼" h
- 208/220-240V
- Additional sizes available



UCBTE008CVI 8 Gallon Capacity

Multifunctional design braises, fries and pressure cooks



Figaro Braising Pan



- Stainless steel construction
- Cooks 4 times faster than a traditional braising pan
- Download HACCP data and recipes via USB
- Pressure lid delivers 6.53 psi
- Motorized tilting lid closure with safety latch and basket lifting system
- 208/220-240V
- 51½" w x 37¾" d x 45½" h

UDFIE027A-D_V2 27 Gallon Capacity



Power through every batch.



Baskett Electric Tilting Kettle



- All stainless steel construction with insulated lid
- Indirect heating with 5 cooking modes
- 2 stainless steel mixing arms with 4 removable POM scrapers
- Heated by armored INCOLOY-800 alloy elements
- Multi-functional electronic control with a 7" touchscreen
- Automatic tilting mechanism
- Can download HACCP data via USB connection
- 208/220-240V
- 57¼" w x 51¼" d x 52½" h

UPRIE048M_V1 48 Gallon Capacity





Tilting Braising Pans

- Classic Controls - Simple control with power switch, temp set knob and heat indicator lamp
- Advanced controls — digital readout, low & high temperature presets and a 1 minute to 10 hour timer
- C2T controls - Same great features as the Advanced control with core probe cooking features added
- Etch marks - gallon and liter
- Faucet bracket
- Patented long/short fin heat distribution design for unmatched cooking uniformity
- 180 emery grit sanded cooking surface for ease of cleaning, less sticking, improved sanitation and pan life
- Industry leading 23 turns to full tilt
- Open tubular design for ease of cleaning and no pinch points
- One piece cover — no welds or tacks to break
- 10-year pan warranty

BPM-40GC	Gas, 40 Gallon Capacity, 48" w x 39 $\frac{3}{4}$ " d x 43 $\frac{3}{8}$ " h, 144,000 BTU
BPM-15EC	Electric, 15 Gallon Capacity, 30 $\frac{1}{2}$ " w x 42" d x 41 $\frac{1}{2}$ " h, 208/240V



BPM-40GC

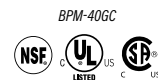

Built for volume.

Gas Tabletop Tilting Kettles

- Constructed of stainless steel
- Gas-powered steam jacketed design
- Classic electronic controls
- Maintains temperatures from 150° to 295°F
- Heavy-duty reinforced rim
- Tilt handle is field reversible for right or left hand tilt
- 115V

TDH-20C	20 qt Capacity, 25 $\frac{1}{2}$ " w x 30 $\frac{1}{2}$ " d x 25 $\frac{1}{4}$ " h, 31,000 BTU
TDH-40C	40 qt Capacity, 28" w x 31 $\frac{1}{2}$ " d x 29 $\frac{1}{2}$ " h, 52,000 BTU



IPX6 water-resistant control housing protects electronics



Stainless steel exterior and cooking surface

SKG-30-SB



Gas Tilting Skillets

- Designed for braising, simmering and pan-frying
- Manual or optional power tilt with manual override
- IPX6-rated water-resistant console
- Solid state controls
- 120V

SKG-30-SB 30 Gallon, 38 $\frac{1}{2}$ "w x 33 $\frac{1}{2}$ "d x 27 $\frac{1}{2}$ "h, 110,000 BTU

SKG-40-SB 40 Gallon, 48 $\frac{1}{2}$ "w x 43 $\frac{1}{2}$ "d x 37 $\frac{1}{2}$ "h, 156,000 BTU



Modular Gas Tilting Braising Pan

- Solid state controls maintain a temperature range of 50° to 425°F
- Stainless steel front, back, sides and 12" legs with adjustable flanged feet
- Stainless steel pan with embossed gallon markings
- Electronic ignition system and watertight control housing
- Manual anti-jam tilt mechanism and automatic burner shut-off
- Includes a spring-assist cover, cool-to-the-touch handle and removable pouring strainer
- 90,000 total BTU
- 36" w x 35 $\frac{1}{2}$ " d x 40 $\frac{1}{2}$ " h
- 1-year limited parts and labor warranty

VG30 30 Gallon Capacity



SHOWN W/
OPTIONAL CASTERS

Cook more with confidence.



Includes embossed gallon and liter markings



Electric Floor Mounted Tilting $\frac{3}{4}$ Jacketed Kettle

- Stainless steel exterior, liner and legs with flanged feet
- Floor mounted, $\frac{3}{4}$ steam jacket is rated to 50 PSI
- Manual self-locking mechanism allows the kettle to tilt 95° for easy emptying
- Includes a water-resistant housing with solid-state temperature control and low-water shut-off
- Splash-proof control housing and low water shut-off for safety
- 208/240V
- 39 $\frac{1}{8}$ " w x 37 $\frac{1}{2}$ " d x 37 $\frac{1}{2}$ " h
- 1-year limited parts and labor warranty

K20ELT 20 Gallon Capacity





Cleveland

SteamCraft® Gemini™ 10 Convection Steamer with Gas Generator & Steam Saver Technology

- Two independent compartments with dedicated generators and controls
- SteamSaver technology auto-adjusts output to save energy and water
- (2) 50,000 BTU gas-fired power burners for fast cook times
- Brass steam jets for even, high-velocity steam distribution
- 14-gauge, 304 stainless steel construction
- Field-reversible doors and 6" adjustable legs
- 24" w x 33½" d x 65½" h

24CGA10.2ES

Holds (10) 12" x 20" x 2½" Pans



Cleveland

SteamChef™ Boilerless Convection Steamer

- Two-compartment, high-speed gas convection steamer with automatic water fill and drain
- 32,000 BTU per compartment for fast cooking
- Fan-forced convection with patented KleanShield condensate removal
- 99-minute SureCook timer with load compensation
- Heavy-gauge stainless steel cooking compartment doors and latches
- 4" adjustable legs with flanged feet
- 1.0 gallon water reservoir per compartment
- 25¾" w x 38¾" d x 70¾" h

(2) 22CGT66.1

Holds (6) 12" x 20" x 2½" Pans per Compartment



Power up the steam.



Smart Steam Pro Gas Boilerless Convection Steamer

- Double stacked single units mounted on a stainless steel stand
- Stainless steel construction and removable stainless steel condensate tray and pan support racks
- 58,000 BTU per compartment
- Water-resistant touchscreen control with self diagnostics and programmable features
- Powerful, side-mounted blower increases steam velocity for efficient distribution throughout cavity and between loaded pans
- Dual water connection per cavity, auto fill and drain, mirrored interior and side-mounted convection fan
- Heats up in 15 minutes or less
- 2.5 gallon water reservoir
- 21¾" w x 36¾" d x 66¾" h
- 1-year warranty extension upon completion of scheduled free Groen startup and 5-year cavity warranty

(2)GSSP-BL-5GS

Holds (10) 12" x 20" x 2½" Pans



Slamable, field-reversible, hands-free stainless steel door latch



Cleveland

SteamCraft® Gemini™ 6 Convection Steamer with Gas Generator

- 2 independent compartments for cooking different foods simultaneously
- (2) 50,000 BTU gas-fired generators, one per compartment
- Durable 14-gauge, 304 stainless steel cavity and steam generator
- SureCook timer with 99-minute digital readout and load compensation
- Automatic water level controls with remote probe-type sensors
- Compartment steam shut-off when door opens
- 6" adjustable stainless steel legs with flanged feet
- 24" w x 33½" d x 59½" h

24CGA6.2S

Holds (3) 12" x 20" x 2½" Steam Pans per Compartment



Pull-out service drawer simplifies maintenance



Intek Electric Countertop Steamer

- Boilerless, connectionless design
- Produces steam at 212°F with no water or drain connection
- Side mounted convection fan
- Durable, stainless steel construction
- Heavy-duty door and magnetic latch
- 3 gallon water reservoir
- 208V
- 23¼" w x 29" d x 30¼" h
- 1-year parts and labor warranty

XS-208-8-3

Holds (6) 12" x 20" x 2½" Pans



SSPE14

Solstice Supreme Pasta Cookers

- High efficiency design
- Stainless steel exterior cabinet and tank
- Solstice burner technology, no blower or ceramics
- Self cleaning burner and down draft protection
- 14" x 18" cooking area
- 12 gallon water capacity



**SSPE14
SSPG14**

Electric, 208-240V
Gas, 60,000 BTU



HyPlus Boiler-Based Steamers

- Pressure boiler in cabinet base generates atmospheric steam at 212°F
- Holds (6) 12" x 20" x 1" pans per cavity
- Automatic fill-and-drain system eliminates manual water handling
- Field reversible, solid doors
- Constructed of stainless steel with a mirror-finished interior
- 34¼" d x 58¾" h
- 200,000 total BTU

High-performance boiler steamer provides instant steam recovery

**HY-6SG-24
HY-6SG-36**

24¾" w
36¾" w



HY-6SG-24



Precision in every batch.

Counter Steamers

- Stainless steel construction
- Hands-free door latch
- 60-minute timer
- Auto fill, manual drain
- Solid swing door
- 24" w x 16 1/2" d
- 208/220/240/480V
- 1-year parts and labor warranty

CSE-4-SB 4 Pan Capacity, 26 1/2" h
 CSE-6-SB 6 Pan Capacity, 33 1/2" h



4-6 position
 cooking modes
 up to 230°F



CSE-4-SB



Rapid, high-volume
 cooking.

Integrated
 water filtration
 system



Atmospheric Steamers



- Stainless steel cooking compartments and cabinet
- Built-in water management system
- Each compartment is individually controlled by an on/off power switch and 60 minute timer
- Standard automatic water level control, low-water cutoff, safety relief valve and preheat thermostat (190°F) and high limit
- Each compartment holds (9) 12" x 20" x 1"d pans, (5) 12" x 20" x 2 1/2" d pans or (3) 12" x 20" x 4" d pans

ETP-10G-SB Gas, 84,000 BTU
 ETP-10E-SB Electric, 20 kW



Heavy-Duty Fryers

- Stainless steel front, sides and fry tank
- Front slanting vessel bottom for quick and easy draining
- Ample cool zone prevents trapped food particle carbonization while extending oil life
- Thermostatic controls maintain temperatures from 200° to 400°F
- Special alloy metal diffuser located in the burner tube for better heat transfer
- Natural gas or liquid propane
- 6" legs or optional casters
- 1-year limited parts and labor warranty, 5-year tank warranty



Dual fry tanks



AF-50/25
SHOWN W/OPTIONAL
CASTERS

	OIL CAPACITY	FRY POT SIZE	BURNERS	DIMENSIONS	BTU
AF-50	50 lb	14" x 14"	3	15½" w x 30½" d x 45¾" h	120,000
AF-75	75 lb	18" x 18"	4	19½" w x 34" d x 46½" h	160,000
DUAL TANK DESIGN					
AF-50/25	(1) 50 lb & (1) 25 lb	(1) 14" x 14" & (1) 6¾" x 14"	5	23¼" w x 30¼" d x 45¾" h	120,000 & 80,000

Cook Rite Gas Fryers

- Stainless steel construction with stainless steel fry tank
- Independent manual controls maintain temperatures from 200° to 400°F
- 2 fry baskets with coated handles
- 4" casters
- 30⅝" d x 44¼" h
- Natural Gas listed, also available in Propane models
- 1-year parts and labor warranty with the option to purchase up to 5-year parts & labor warranty



ATFS-40ES	40 lb Oil Capacity, 3 Burners, 66,000 BTU, 15½" w
ATFS-50ES	50 lb Oil Capacity, 4 Burners, 88,000 BTU, 15½" w
ATFS-75ES	75 lb Oil Capacity, 5 Burners, 110,000 BTU, 21⅝" w



ATFS-40ES

Wide cooling zone traps food particles to preserve oil quality & flavor

Ventless Countertop Fryers

- Ventless countertop design allows for deep frying
- Patented HEPA-style air filtration with activated carbon eliminates odors
- The fully automatic PFA Series offers programmable presets, automatic cook time adjustments and front loading/dispensing
- The semi automatic PFC Series offers programmable presets
- Integrated fire suppression system and safety interlocks
- 3 operating modes including manual, preset and rapid fry
- 208/240V
- 1-year parts and labor warranty



PFA500

	OIL CAPACITY	FRIES/HR	DIMENSIONS
PFA SERIES			
PFA500	2.9 gal	70 lb	17" w x 27" d x 30" h
PFA730	2.9 gal	90 lb	17" w x 27" d x 30" h
PFC SERIES			
PFC500	2 gal	45 lb	17" w x 16" d x 23" h
PFC730	2 gal	60 lb	17" w x 16" d x 23" h



Frymaster

High-Efficiency Gas Fryer

- 35 lb oil capacity
- 14" x 13¾" x 4⅝" frying area
- Millivolt control system - requires no electrical hookup
- Thermo-Tube design with 6" tubes
- Wide cold zone
- Wire form basket hanger and 2 fry baskets
- 6" adjustable steel legs
- Stainless steel frypot, front, door, backsplash/flue cover and sides

ESG35T 70,000 BTU



High-Efficiency Gas Fryer with Built-in Filtration

- 50 lb oil capacity
- 14" x 15" x 4½" frying area
- Open-pot design with a deep cold zone and forward sloping bottom
- Energy-saving, high efficiency performance
- Infrared burner system
- Durable stainless steel frypot, door and cabinet sides
- Programmable touchpad controls
- Integrated filtration system completes a full cycle in under five minutes
- CM3.5 controls
- Includes casters
- 25" w x 29½" d x 45½" h
- 7-year parts warranty

FPH155 80,000 BTU

Frymaster



State-of-the-art heat transfer system



High-Efficiency Electric Fryer with Built-In Filtration

- (2) 14" x 15½" x 3½" frying areas
- Built-in manual filtration
- Stainless steel frypot, door and cabinet sides
- Self-standing, rotating 1" ribbon heating elements deliver faster recovery, improved energy efficiency and easy, safe cleaning
- Programmable controls can store up to 12 recipes
- Includes casters
- 47" w x 31" d x 45½" h

FPRE214 208/240V

Dual 50 lb open frypots



Frymaster



Perfectly crispy every time.

TIP

Best Tips For Filtering Fryer Oil

Regularly filtering your fryer oil will improve food quality and extend oil life.

1. Turn off the power to the fryer and allow the oil to cool to a safe handling temperature.
2. Once oil has cooled, open the drain valve and carefully release the oil into the filtration system or a designated container.
3. Remove any large food particles from the fryer basket and interior.
4. If your unit includes a built-in filtration system, activate it according to the manufacturer's instructions.
5. For manual systems, strain the oil through a filter cone or paper to remove sediment before returning the oil to the fryer.
6. Before refilling, wipe down the fry pot to prevent carbon buildup.
7. Schedule filtration as part of your daily routine to ensure consistent flavor, reduce waste and keep your fryer performing at its best.





Super Runner® Gas Fryer

- 43 lb oil capacity
- 14" x 13¾" x 4½" frying area
- Fast temperature recovery between batches
- Thermo-Tube design extends oil life to lower operating costs
- Wide cold zone collects sediment to maintain efficient heat transfer
- Twin frying baskets
- Stainless steel frypot and door
- 6" adjustable steel legs
- 15½"w x 29½"d x 45"h

SRI42 105,000 BTU



Gas Fryer

- 50 lb oil capacity
- 14" x 15" x 5" frying area
- Master jet burner and millivolt temperature controls
- Large cold zone safeguards oil quality
- Stainless steel frypot, door and aluminized sides
- Open pot aids in the management of sediment buildup for better oil quality and easier cleaning
- Produces 69 lb of fries per hour
- Available in Natural Gas or LP
- Twin baskets
- Casters included
- 15½" w x 30¾" d x 46¾" h

GF40 122,000 BTU



PowerRunner® Gas Fryer with Built-In Filtration

- High-performance gas fryer with 50 lb oil capacity and built-in filtration
- 14" x 14" x 3½" frying area
- Thermo-tube heat transfer system
- Stainless steel baffles and durable burners
- Millivolt controller and temperature probe
- Wide cold zone at bottom of frypot
- 4-GPM filter pump
- Filter starter kit
- Stainless steel frypot, door and sides
- 2 twin baskets included
- Includes casters
- Drain safety switch
- 15½" w x 30¾" d x 46" h

1FPRG50T 120,000 BTU



Built-in filter uses gravity-draining system



PowerRunner® Gas Fryer

- 50 lb oil capacity
- 14" x 14" x 3½" frying area
- Thermo-tube heat transfer system
- Wide cold zone traps sediment
- Millivolt control system does not need an electrical connection
- Stainless steel frypot, front, door and aluminized sides
- 2 twin frypots with basket hanger and support racks
- Casters are optional
- 15½" w x 30¾" d x 44½" h

1PRG50T-SPV 120,000 BTU



Reduced Oil Volume Rack Fryers

- Cooks up to 64 pieces bone-in chicken or 60 chicken strips
- Offers 13% reduction in oil volume
- Lift assist system with 5 slot rack holder
- 14" x 18" x 10" frying area
- Stainless steel tank and cabinet
- 1½" full port drain for fast draining
- Drain valve interlock
- Advanced Automatic Filtration process makes filtering quick and easy
- 10 GPM filter pump
- 9" adjustable legs for leveling fryer
- 76 lb oil capacity

SGLVRF
SELVRF

Gas
Electric



ELECTRIC



GAS



DUAL MODEL SHOWN WITH K12
COMPUTER & OPTIONAL CASTERS



Open-vat
stainless steel
frypot design



Garland Cuisine Series Heavy-Duty Range Match Gas Fryer

- 35 lb oil capacity
- Stainless steel frypot, door, front rail, sides and legs
- Integrates flush with Garland Cuisine Series equipment for a unified, high-efficiency cook line
- 6" adjustable legs
- 2 chrome wire baskets
- 18" w x 39¼" d x 43¾" h

C18-35F

110,000 BTU

GARLAND



GARLAND

Garland Cuisine Series Heavy-Duty FryMate Dump Station

- Constructed of durable stainless steel
- Includes a full-size 12" x 20" x 2½" stainless steel food pan and wire rack screen
- Wire rack screen allows excess oil to drain for crisp results
- Storage base provides access to breadings, baskets or utensils
- Can be installed individually or in a battery, the perfect mate for the Garland C18-35F Fryer
- 6" adjustable stainless steel legs

C18-FMD

18" w x 41½" d x 43¾" h



Shown with optional
heat lamp



High volume frying.
Excellent results.



SSH55



Solstice Supreme Gas Fryers

- Stainless steel tank, cabinet, front, doors and sides
- Solstice™ burner technology, no blower or ceramics
- Self cleaning burner and down draft protection
- Solid state t-stat with melt cycle and boil out mode
- Matchless ignition with DVI (drain valve interlock)
- Heavy-duty 3/8" bottom door hinge
- 1/4" full port drain valve
- Separate manual gas shutoffs, for front servicing
- Integrated flue deflector
- Drain line clean out rod
- Tube rack
- Drain extension
- 9" adjustable legs



	OIL CAPACITY	BTU
SSH55	40 to 50 lb	80,000
SSH60	50 to 60 lb	80,000
SSH75	75 lb	105,000



Easy, simple cleaning



Tube-Fired Gas Fryers

- Stainless steel fry tank, front and door
- Stainless steel heat baffles
- Thermostat maintains selected temperature between 200° to 400°F
- 2 nickel plated wire mesh baskets included

	OIL CAPACITY	FRIES/HR	BTU
35C+S	35-40 lb	63 lb	90,000
45C+S	42-50 lb	86 lb	122,000
65C+S	65-80 lb	115 lb	150,000



Turn up the heat and fry like a pro.

Solstice Fryers

- Stainless steel tank, front, door and sides
- High temperature safety switch
- 14" x 14" or 18" x 18" fry area
- 1/4" full port drain valve
- 9" adjustable legs
- Removable basket hanger
- Drain line clean out rod

Electric Fryers

- Fixed heating elements for ENERGY STAR® performance
- Solid state thermostat
- 208, 220, 240V

Gas Fryers

- Separate manual gas shutoffs
- Self cleaning burner and down draft protection
- Millivolt thermostat

	WIDTH	OIL CAPACITY	BTU
ELECTRIC SE14†	15 1/2"	40-50 lb	—
SE18†	19 1/2"	60-90 lb	—
GAS SG14-S	15 1/2"	40-50 lb	110,000
SG18-S	19 1/2"	70-90 lb	140,000

†ENERGY STAR®

Choice of 2 twin baskets or 1 full basket



SE140 SHOWN W/ OPTIONAL CASTERS

SE18 SHOWN W/ OPTIONAL DIGITAL CONTROLS & CASTERS

IMPERIAL**Tube Fired Side Car Fryer Filter Systems**

- Integrates frying, oil filtration, food warming and dumping into a single cabinet station
- Powerful 5.5 GPM roller-pump provides rapid oil filtering and return
- Under-fryer placement and internally plumbed lines
- Stainless steel construction with a 5" deep stainless steel front landing ledge
- Available with Snap Action Thermostats, Electronic Thermostats or Computer Controls
- Can pump oil into a disposal vat up to 20 feet away
- Casters, joiner strips, and filter starter kit included
- 115V
- Available for 50 lb and 75 lb oil capacity fryers

	FRYERS	DIMENSIONS
IFSCB150	1	31" w x 33¼" d x 51½" h
IFSCB350	3	62" w x 33¼" d x 51½" h
IFSCB650	6	108½" w x 33¼" d x 51½" h



IFSCB250

Space Saver Tube Fired Fryer Filter Systems

- Integrates with up to 6 fryers for centralized oil filtration
- Internally plumbed lines and quick-disconnect fittings
- Continuous stainless steel cabinet, fry pot and 5" front landing ledge
- 5.5 GPM pump with a ½ hp motor speeds up filtering process
- Available with Snap Action Thermostats, Electronic Thermostats or Computer Controls
- Available for 50 to 75 lb oil capacity
- Can pump oil into a disposal vat up to 20 feet away
- Includes casters, joiner strips and filter starter kit
- 115V
- Additional sizes available

	FRYERS	DIMENSIONS
IFSSP275	2	39" w x 39" d x 46½" h
IFSSP375	3	58½" w x 39" d x 46½" h
IFSSP575	5	97" w x 39" d x 46½" h

IMPERIAL**IMPERIAL**SEHD SHOWN W/
OPTIONAL CASTERS**Elements Series Gas Fryer**

- 40 lb oil capacity
- 105,000 BTU tube-fired system
- Large cool zone captures food particles
- Stainless steel front, door, basket hanger and steel frypot
- Full bottom chassis and plate-mounted legs
- Millivolt temperature control circuit
- 14" x 14" frying area
- 6" adjustable legs
- Maintains oil temperature from 200° to 400°F

3 cast iron
tube-fired
burners

EFS-40 15½" w x 30½" d x 45¾" h



Automatic basket lift with push-button operation



Ventless Fryer With Auto-Lift & Cabinet Base

- High-production frying without expensive Type-1 ventilation
- Entirely self-contained, 3-stage filtration
- 55 lb oil capacity
- Paperless filtration system extends oil life and reduces labor
- 2 automatic basket-lifting mechanisms, each controlled by a push-button automatic reset timer
- Integrated ANSUL® fire suppression for built-in protection
- Stainless steel body and fry pot with a flat bar element with a low watt density for longer oil life
- Include 2 full-size, rear hanging fry baskets
- Automatic oil temperature control
- 208-240V



WVAE 55F 15³/₁₆"w x 43¹/₁₆"d x 76¹/₂"h



QUICKFRY™ Gas Fryers

- 50 lb capacity
- Stainless steel cabinet and fry tank
- 4 heat exchanger tubes provide fast temperature recovery
- Maintains precise temperatures from 150° to 390°F
- Integrated hi-limit shut-off and drain valve interlock
- Includes electronic matchless ignition for quick and safe startups
- 15¹/₂"w x 32¹/₁₆"d x 47³/₄"h
- 13³/₁₆" x 14¹/₁₆" frying area
- Twin baskets
- 120V
- 6" casters
- Models available with analog (A), digital (D) or computer (C) controls
- 1-year limited parts and labor warranty, 10-year limited tank warranty



1VHG50 15¹/₂"w x 32¹/₁₆"d x 47³/₄"h



PowerFry 3™ Freestanding Gas Fryers

- Stainless steel fry tank and cabinet construction
- Features the patented ThreePass™ heat transfer system
- 70,000 BTU
- SoftStart™ ignition system
- Maintains temperature to within 2°F of the setpoint
- Large V-shaped cold zone protects oil quality
- 15¹/₂"w x 30¹/₁₆"d x 47³/₄"h
- 14" x 14" frying area
- 6" casters, 2 locking
- 2 fry baskets with plastic coated handles
- Models available with analog (A), digital (D) or computer (C) controls
- 10-year limited tank warranty, 1-year parts and labor warranty

TR45 40-50 lb



ER Series Freestanding Electric Fryer

- Stainless steel front, sides and fry tank
- 17 kW ribbon style heating elements
- Multiple fat melt modes
- High limit control
- Twin fry baskets with plastic coated handles
- 50 lb oil capacity
- Maintains temperatures from 200° to 390°F
- 6" adjustable legs
- Models available with analog (A), digital (D) or computer (C) controls
- 1-year limited parts and labor warranty, 10-year limited fry tank warranty

1ER50 15¹/₂"w x 34³/₁₆"d x 39¹/₁₆"h



TTR45A

1ER50A W/
OPTIONAL CASTERS

Blue Hose® Gas Connector Kit with Excess Flow Valve (EFV) Safety Technology

- Excess Flow Valves (EFVs) drastically reduce the risk of gas leaks
- Blue Hose® gas connector kits offer enhanced safety for commercial kitchens
- Limits gas flow if the connector is disconnected or ruptured
- Helps prevent fires and explosions caused by gas leaks
- Safeguards your staff, property and business
- Temperature range up to 350°F
- ¾" inside diameter
- All kits include push-to-connect quick disconnect with thermal shutoff, restraining cable and mounting hardware

36" LONG

1675KIT36EFV Kit w/ (2) Street Elbows

1675KITS36EFV Kit w/ (1) Swivel & (1) Street Elbow

1675KIT2S36EFV Kit w/ (2) Swivels

48" LONG

1675KIT48EFV Kit w/ (2) Street Elbows

1675KITS48EFV Kit w/ (1) Swivel & (1) Street Elbow

1675KIT2S48EFV Kit w/ (2) Swivels



1675KIT2S48EFV



Dormont
A WATTS Brand



1675KIT48EFV



1675KITS48EFV



Safety in every connection.

VULCAN

Portable Fryer Filter System

- Stainless steel handle, filter vessel and filter pan
- Circulates hot oil at 8 gallons per minute with a ½ hp motor and pump
- Removable stainless steel crumb basket and mesh screen
- Includes a 4' high-temperature hose for safe oil discard
- 6" casters
- 120V
- 20" w x 39" d x 20" h
- 1-year limited parts and labor warranty

MF-1 110 lb Oil Capacity



Safe-T-Link Gas Appliance Connector Kit

- Kit includes: 48" braided hose with extruded coating and ¾" NPT male connections, 1 quick-disconnect, (1) 90° street elbow, 1 CSA-certified gas ball valve, 1 restraining cable and all necessary hardware

HG-4D-48K

T&S
RELIABILITY BUILT IN™

All in one gas connector kit





Look beyond the hood.

Complete Kitchen Ventilation Systems

It's common to focus on the hood, but real performance—and day-to-day comfort—depends just as much on how fresh air is brought into the space. The type of supply air system you use, whether a traditional Make-up Air Unit (MAU) or a Dedicated Outdoor Air System (DOAS) has a big impact on how well your hood captures smoke and heat, how your kitchen feels and even how hard your HVAC system has to work. Controls are another important piece. In many cases, the hood must ship with the system's controls, which can get complicated if the hood comes from one supplier while fans or MAU/DOAS equipment come from others. Understanding how these parts fit together helps avoid delays, unexpected costs or performance issues. It's important to look at the full system, not just the hood, and to lean on local experts as needed.

Think Beyond the Hood: A complete ventilation system includes hood, exhaust fan, supply air equipment and controls. All four must work together to keep your kitchen comfortable, code-compliant and operating efficiently.

Understand Your Supply Air Options: The method chosen and how they're balanced directly affect hood selections, system performance and kitchen comfort.

- **Make-up Air Units (MAU):** Designed to balance the space and help maintain proper air pressure with heated, cooled, or untempered air.
- **DOAS or Packaged Rooftop Units:** Provide HVAC air for conditioning of the space as well as the make-up air for the hood.

Controls Matter

Ventilation systems often rely on integrated control like fan starters, VFDs, interlocks and sensors. Coordination is essential to avoid installation or startup issues.



EcoArch Ventilation Hoods

- Kitchen ventilation designed for open-concept layouts
- Utilizes a patented arch design with high-velocity extraction to capture grease
- Creates less air volume and turbulence for a significantly quieter operation
- Features front-mounted grease extraction cartridges and a grease cup for easy access
- 3" rear air space
- For use up to 600 °F



EA4000 Exhaust Only
EA4000P Exhaust with Make-Up Air



EA4000

Wall & Island Utility Distribution Systems

- Centralizes kitchen utility connections to simplify installation and layout changes
- Allows for equipment relocation and redesign without costly remodeling
- Stainless steel raceway construction protects internal electrical and plumbing services
- Integrated safety systems include fire-fuel shut-off and ground fault protection

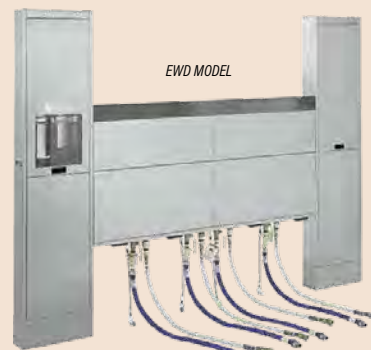

EWD MODEL

EWD MODEL, E SERIES Wall Utility, Multiple Sizes
EID MODEL, E SERIES Island Utility, Multiple Sizes



4-stage filtration removes grease, smoke and odors



Universal Ventless Hood

- 96" cooking zone accommodates multiple electric appliances
- Self-contained ANSUL® fire suppression enhances kitchen safety
- Stainless steel construction
- 6 bright LED lights improve cook surface visibility
- 1½ hp
- 208-240V
- 6" to 8" adjustable legs
- Limited 2-year parts warranty and 1-year labor warranty

WVU-96 113 3/8" w x 50" d x 120" h

Delivering Commercial Kitchen Solutions Since 1987



CODE-COMPLIANT VENTILATION SOLUTIONS

From full-service restaurants to food trucks, we deliver reliable ventilation systems built-to-perform, quick-to-install and supported by ventilation experts from start to finish.

- **Exhaust & Makeup Air Hoods** - UL Listed Type 1 ventilation systems that remove grease-laden vapors while supplying tempered or untempered replacement air for balanced airflow and improved kitchen comfort
- **Type 2 Hoods** - Economical ventilation for heat and steam-producing equipment
- **Concession Hoods** - Compact systems ideal for food trucks and mobile kitchens
- **Ventless Hoods** - Self-contained systems for electric equipment where ducting isn't possible
- **Fire Suppression Systems** - Factory-installed Ansul® or Kidde® UL 300-compliant protection
- **Exhaust & Supply Fans** - High-efficiency fans built for reliable airflow and long service life



2-YEAR WARRANTY - HOOD PACKAGES, HOODS, & FANS ONLY

SPEED

5-7 days shipping keeps your kitchen project on track*

**Lead times are business days from order; complex projects may take longer*

QUALITY

Full-line hood manufacturer with UL/NSF listings



SUPPORT

From specs to code approval, you can count on guidance from a dedicated expert rep



Edge-to-edge heat.



ACCUSTEAM® Steam-Heated Griddles

- Cold-rolled and annealed stainless steel griddle plate with polished stainless steel body
- 7 gauge griddle plate with 4" high rear splash and tapered side walls
- Full front grease trough
- Efficient steam heat transfer provides 200° to 400°F (±5° operating temperature range)
- Digital thermostat with 3 programmable presets and easy front service access to controls
- Electric models are backed by the industry's ONLY Lifetime Service and Support Guarantee



GAS	COOKING AREA	DIMENSIONS	BTU
GGF1201B2450-T1	574 sq in	24 $\frac{1}{4}$ "w x 32 $\frac{3}{8}$ "d	42,300
GGF1201B3650-T1	862 sq in	36 $\frac{1}{4}$ "w x 32 $\frac{3}{8}$ "d	70,000
GGF1201B4850-T1	1150 sq in	48 $\frac{1}{4}$ "w x 32 $\frac{3}{8}$ "d	85,000
GGF1201A2450-T1	717 sq in	24 $\frac{1}{4}$ "w x 38 $\frac{3}{8}$ "d	42,300
GGF1201A3650-T1	1077 sq in	36 $\frac{1}{4}$ "w x 38 $\frac{3}{8}$ "d	70,000
GGF1201A4850-T1	1437 sq in	48 $\frac{1}{4}$ "w x 38 $\frac{3}{8}$ "d	85,000

ELECTRIC	COOKING AREA	DIMENSIONS	BTU
EGF****B2450-T1	574 sq in	24 $\frac{1}{4}$ "w x 28 $\frac{3}{8}$ "d	—
EGF****B3650-T1	862 sq in	36 $\frac{1}{4}$ "w x 28 $\frac{3}{8}$ "d	—
EGF****B4850-T1	1150 sq in	48 $\frac{1}{4}$ "w x 28 $\frac{3}{8}$ "d	—
EGF****A2450-T1	717 sq in	24 $\frac{1}{4}$ "w x 34 $\frac{3}{8}$ "d	—
EGF****A3650-T1	1077 sq in	36 $\frac{1}{4}$ "w x 34 $\frac{3}{8}$ "d	—
EGF****A4850-T1	1437 sq in	48 $\frac{1}{4}$ "w x 34 $\frac{3}{8}$ "d	—

Replace **** with Voltage & Phase, i.e. 2083

AccuTemp

XLR8™ Upper Heated Platen

- Mounts to 24" deep gas or electric AccuSteam™ griddles for two-sided cooking capabilities
- Cuts cook times by 50% or more by eliminating the need to flip product
- Delivers precise, even temperature from 200° to 440°F
- Features digital controls with programmable presets
- Heavy-duty stainless steel construction with removable Teflon sheets
- Made in USA
- 240V
- 1-year parts and labor warranty

XLR82401B-00

11¹/₁₆" w x 23³/₁₆" d



Heavy-duty stainless steel construction with removable Teflon sheet



Double the heat, half the wait.



ATMG-48



Gas Griddles

- Stainless steel exterior and interior
- Stainless steel grease drawer
- Heavy-duty 1" thick polished steel griddle plate
- Thermostatic models feature 25,000 BTU burners per 12" section with standby pilots
- Manual models feature 30,000 BTU burners per 12" section with standby pilots
- Stainless steel legs, standard
- 3/4" NPT rear gas connection and regulator standard
- 28³/₁₆" d x 15¹/₁₆" h
- 1-year parts & labor warranty with option to purchase up to a 5 year warranty

Independent manual controls for each burner



THERMOSTATIC	WIDTH	BURNERS	BTU
ATTG-24	24"	2	50,000
ATTG-36	36"	3	75,000
ATTG-48	48"	4	100,000

MANUAL	WIDTH	BURNERS	BTU
ATMG-24	24"	2	60,000
ATMG-36	36"	3	90,000
ATMG-48	48"	4	120,000

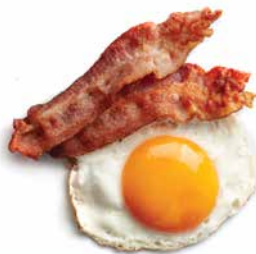

ARSMG-36

Gas Griddles

- Gas-powered countertop griddles for high-volume cooking
- Thick 1" steel griddle plate provides superior heat retention
- Powerful 30,000 BTU burner for every 12" of cooking surface
- Stainless steel front, sides and landing ledge for lasting service
- Spacious 21" cooking depth accommodates a variety of menu items
- 4" adjustable inset legs for stable placement on countertops
- 32³/₁₆" d x 12³/₁₆" h
- 2-year limited parts and labor warranty



THERMOSTATIC	WIDTH	BURNERS	BTU
ARSTG-12	12"	1	30,000
ARSTG-24	24"	2	60,000
ARSTG-36	36"	3	90,000
ARSTG-48	48"	4	120,000
ARSTG-60	60"	5	150,000
ARSTG-72	72"	6	180,000

MANUAL	WIDTH	BURNERS	BTU
ARSMG-12	12"	1	30,000
ARSMG-24	24"	2	60,000
ARSMG-36	36"	3	90,000
ARSMG-48	48"	4	120,000
ARSMG-60	60"	5	150,000
ARSMG-72	72"	6	180,000





Griddles that keep up.



Heavy-Duty Counterline Gas Griddles

- 1" thick smooth polished plate
- Stainless steel front and sides
- "Insta-on" thermostatic controls (150° to 400°F)
- 30,000 BTU burner every 12"
- Hidden grease drawers
- Exclusive NO COLD Zone
- Embedded load sensing thermostat
- Spark ignition standard
- 33 $\frac{3}{4}$ "d x 20"h
- 1-year parts and labor warranty



	WIDTH	BURNERS	BTU
HDG-24	24"	2	60,000
HDG-36	36"	3	90,000
HDG-48	48"	4	120,000
HDG-60	60"	5	150,000
HDG-72	72"	6	180,000



HDCS-36 SHOWN ON
OPTIONAL MOBILE STAND

Heavy-Duty Counterline Stands

- 2" stainless steel tubular legs
- Adjustable bullet feet
- Optional casters available

HDCS-24	24"w
HDCS-36	36"w
HDCS-48	48"w
HDCS-60	60"w
HDCS-72	72"w



All stainless steel welded construction



HDCS-60
STAND SHOWN WITH COUNTERLINE EQUIPMENT
(SOLD SEPARATELY) AND OPTIONAL CASTERS

COUNTER EQUIPMENT



824TA

Stainless steel
4½" tapered
splash guard



624TF

Ultra-Max® Snap-Action Thermostat Gas Griddles

- Heavy-duty all-welded body with stainless steel front, side panels and bull nose
- Ultra-smooth 1" thick steel plate - 24" deep
- 3½" w front access grease trough with 6 qt grease drawer capacity
- Includes a 30,000 BTU aluminized burner every 12" of width controlled by snap action control valve with standing pilot light
- Snap action thermostat control, 150° to 550°F
- 4" adjustable legs
- 34½" d x 18" h
- Models available with Manual controls
- 2-year parts & labor warranty

	WIDTH	BURNERS	BTU
824TA	24"	2	60,000
836TA	36"	3	90,000
848TA	48"	4	120,000
860TA	60"	5	150,000
872TA	72"	6	180,000



Star-Max® Thermostatic Gas Griddles

- Highly polished 1" thick steel plate
- 28,300 BTU aluminized steel U-shaped burner every 12"
- New longer lasting, heavy duty metal knobs
- Stainless steel front bullnose and 4½" splash guards
- Thermostatic controls
- Shipped natural gas with LP conversion kit
- 29" d x 15½" h
- Models available with Manual controls
- 2-years parts & labor warranty

	WIDTH	BURNERS	BTU
615TF	15"	1	28,300
624TF	24"	2	56,600
636TF	36"	3	84,900
648TF	48"	4	113,200



Perfect temperature every time.



VULCAN

VCCG Series Heavy-Duty Gas Griddles

- Stainless steel front, sides and front top ledge
- 1" thick polished steel griddle plate with top seam welding
- Stainless steel 4" back and tapered side splashes
- Temperature adjusts from 150° to 550°F
- 24" x 24" cooking surface
- (2) 30,000 BTU atmospheric burners
- Available in natural or propane gas with options for infrared burners
- 1-year limited parts and labor warranty

VCCG24-AC 24" w x 33½" d x 18½" h



VULCAN

MSA Series Heavy-Duty Gas Griddle

- Stainless steel front, sides and front top ledge with "Cool Bullnose" design
- 1" thick stainless steel griddle plate
- Fully welded frame
- Manual ignition
- 24" x 24" cooking surface
- 54,000 BTU
- 4" legs
- 1-year limited parts and labor warranty

MSA24 24" w x 24" d x 15½" h on 4" legs



ATCB-48



Gas Charbroilers

- Stainless steel exterior and interior
- 35,000 BTU stainless steel burners every 12" with standby pilot
- Heavy-duty, reversible cast iron grates
- Top grates can be adjusted to multiple levels
- Adjustable, stainless steel legs
- Char Rock models include lava briquettes
- 27⁹/₁₆"d x 15¹/₂"h
- 1-year parts and labor warranty with option to purchase up to a 5-year warranty

Independent manual controls for each burner



RADIANT	WIDTH	BURNERS	BTU
ATRC-24	24"	2	70,000
ATRC-36	36"	3	105,000
ATRC-48	48"	4	140,000
CHAR ROCK			
ATCB-24	24"	2	70,000
ATCB-36	36"	3	105,000
ATCB-48	48"	4	140,000



ARSRB-36



Radiant Charbroilers

- Heavy-duty countertop charbroiler designed for radiant heat cooking
- Burners placed every 6" for consistent heat across the cooking surface
- Heavy-duty cast iron radiants provide superior, even heat distribution
- Reversible cast-iron grates feature two positions for cooking versatility
- Stainless steel construction on front, sides and landing ledge
- Includes a 4" backsplash and a removable stainless steel grease pan
- 4" adjustable legs for stable countertop placement
- 30"d x 12⁹/₁₆"h
- 2-year limited parts and labor warranty

	WIDTH	BURNERS	BTU
ARSRB-12	12"	2	30,000
ARSRB-24	24"	4	60,000
ARSRB-36	36"	6	90,000
ARSRB-48	48"	8	120,000
ARSRB-60	60"	10	150,000
ARSRB-72	72"	12	180,000



Star-Max® Gas Charbroilers

- 40,000 BTU H-style cast iron burners every 12" of width
- Heavy-duty, reversible cast iron grates can be individually positioned (flat or slanted)
- Stainless steel, 2³/₄" high tapered splash guard
- Shipped natural gas with LP conversion kit
- 29"d x 15¹/₂"h
- 2-years parts & labor warranty



Lava Rock

- Natural lava rock briquettes provide superior heat distribution and vaporize drippings

Radiant

- Radiant models feature heavy-duty stainless steel radiants
- Stainless steel construction

LAVA ROCK	WIDTH	BURNERS	BTU
6015CBF	15"	1	40,000
6024CBF	24"	2	80,000
6036CBF	36"	3	120,000
6048CBF	48"	4	160,000

RADIANT	WIDTH	BURNERS	BTU
6115RCBF	15"	1	40,000
6124RCBF	24"	2	80,000
6136RCBF	36"	3	120,000
6148RCBF	48"	4	160,000



Ultra-Max® Gas Charbroilers

- Corrosion resistant stainless steel body
- 20,000 BTU cast iron burner every 6" of width with separate control knob for each section for maximum heat and flexibility
- High-capacity cast iron grates for maximum efficiency
- 5" tapered splash guard and large capacity water pan for easy cleanup
- Cool-to-the-touch stainless steel bullnose protects knobs and keeps work area comfortable
- Heavy-duty metal knobs are designed to last
- 35³/₁₆"d x 18"h
- Available in other sizes
- 2-year parts & labor warranty



	WIDTH	BURNERS	BTU
8124RCBB	24"	4	80,000
8136RCBB	36"	6	120,000
8148RCBB	48"	8	160,000
8160RCBB	60"	10	200,000
8172RCBB	72"	12	240,000

COUNTER EQUIPMENT



HDC-36



Heavy-Duty Counterline Gas Charbroilers

- Field convertible from radiant to briquette
- Stainless steel burners and cast iron grates
- Two position, two-sided cooking grates
- Universal gas regulator in rear
- 40,000 BTU every 12"
- Hidden grease drawers
- Built-in splash guard
- All units 30"d x 16"h
- 1-year parts and labor warranty

HDC-36	36"w
HDC-48	48"w
HDC-60	60"w

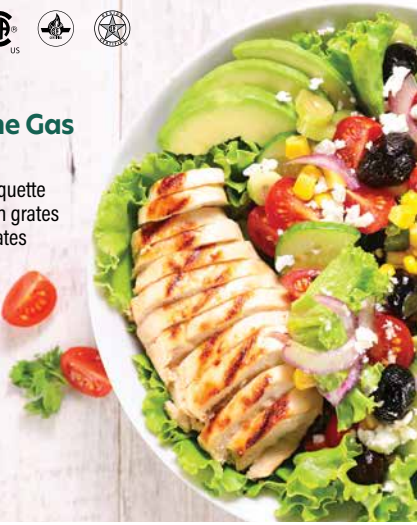

ARSHP-36-3

ARSHP-36-6



Gas Hot Plates

- High-performance gas hot plates for countertop cooking applications
- Features powerful 32,000 BTU two-piece lift-off burners
- Heavy-duty 12" x 12" removable cast iron grates support heavy stockpots
- Manual gas control valves provide precise temperature management for each burner
- Stainless steel standing pilots offer reliable, instant ignition
- Full-width removable stainless steel crumb tray simplifies cleaning
- 4" adjustable legs provide stability on uneven surfaces
- 30"d x 12³/₁₆"h
- 2-year limited parts and labor warranty

	BURNERS	DIMENSIONS	BTU
ARSHP-12-2	2	12" w x 30" d x 12 ³ / ₁₆ " h	64,000
ARSHP-24-2	2	24" w x 18" d x 12 ³ / ₁₆ " h	64,000
ARSHP-24-4	4	24" w x 30" d x 12 ³ / ₁₆ " h	128,000
ARSHP-36-3	3	36" w x 18" d x 12 ³ / ₁₆ " h	96,000
ARSHP-36-6	6	36" w x 30" d x 12 ³ / ₁₆ " h	192,000
ARSHP-48-4	4	48" w x 18" d x 12 ³ / ₁₆ " h	128,000
ARSHP-48-8	8	48" w x 30" d x 12 ³ / ₁₆ " h	256,000
ARSHP-60-10	10	60" w x 30" d x 12 ³ / ₁₆ " h	320,000



SE-HDG11R

Hot Dog Roller Grills with Sneeze Guards

- Adjustable thermostat: 0°F to 250°F
- Independent front and rear heating zones
- Commercial-grade stainless steel construction
- Curved tempered glass sneeze guard for enhanced visibility and contamination prevention (Included)
- Non-stick stainless steel rollers
- Removable stainless steel drip tray for easy cleaning
- Built-in safety fuse
- 120V
- 23"l x 7"h
- 1-year parts and labor warranty

	DEPTH	ROLLERS	HOT DOGS
SE-HDG5R	10 ³ / ₈ "	5	12
SE-HDG7R	13 ¹ / ₄ "	7	18
SE-HDG11R	19 ¹ / ₈ "	11	30



36IRB



Heavy-Duty Gas Salamander Broilers

- Designed for finishing, melting and browning
- Stainless steel front, top and sides
- Dual heat controls enable precise zone cooking from 250° to 800°F
- Heavy-duty chrome-plated broiling grid with 6 adjustable positions
- Cool-to-the-touch lever knob allows for safe adjustment of the broiler carriage
- Removable full-width spillage pan simplifies cleanup
- Available in Natural Gas (-N) and Propane (-P)
- 36" w x 19" d x 17³/₁₆" h
- 1-year limited parts and labor warranty

36IRB	Infrared
36RB	Radiant





Electric Salamanders



People who serve, products that solve.™

- Stainless steel construction
- Flat touch control panel
- High-powered infrared ribbon heating elements
- Adjustable hood gives 4½" of vertical movement
- HOLD function has eight programmable heat levels and is ideal for keeping food hot or for reheating food
- Removable cooking grate and drip tray
- Use for countertop cooking or can be mounted on wall - hardware included
- 21¾" x 13¾" Cooking Area
- 208V or 240V models available
- 1-year on-site parts and labor warranty



SAL-1 22¾" w x 21¾" d x 23¾" h



From sandwiches & quesadillas.



People who serve, products that solve.™

Panini Grills

- Compact countertop grill designed for versatile, high-speed cooking
- Features a stainless steel body with durable aluminum cooking plates
- Exclusive heating elements offer exceptional heat distribution
- Reaches temperatures up to 500°F
- Self-adjusting top plate accommodates products up to 3" thick
- Digital time and temperature controls for consistent, repeatable results
- Includes a removable grease trough for simplified cleaning
- 16½" w x 17½" d x 8½" h
- 120V

- PG14G-1 Grooved Top & Bottom Plates
- PG14F-1 Flat Top & Bottom Plates
- PG14FG-1 Grooved Top & Flat Bottom Plates

Designed for fast searing and grilling



COUNTER EQUIPMENT



Grooved upper and smooth lower plate



Combo Plate Sandwich Grill

- Stainless steel construction
- Seasoned cast iron plates
- Thermostatic controls heat up to 570°F
- Heavy-duty spring hinge with adjustable tension
- 1-year warranty on parts, labor and travel

GPGS14D 14" x 14" Cooking Surface



Grill. Press. Serve.

MERRYCHEF



Panini Press Kit

- The perfect accessory for conneX[™]12 and eikon[™]e2s
- Simple to install, the panini press replaces the cook plate in the oven's cavity
- Kit includes paddle, ceramic-coated top grill plate, bottom flat plate and 2 food liners
- Dishwasher safe
- Models available with double grill plates and high or low opening features

PSR162 High Opening, Top Grill & Bottom Flat Plates, 11³/₈"w x 10¹/₄"d x 4"h



Features ribbed cast iron plates for even heating

Ribbed Panini Grill

- Durable stainless steel construction
- Ribbed cast iron grill plates provide the iconic panini sear
- Adjustable thermostat allows for precise temperature control up to 570°F and the ready light indicates when grill has reached desired temperature
- Hinged and balanced top plate adjusts for food thickness
- Removable crumb and grease tray included for no-mess cooking
- 1750W, 120V

EPG-1C 14" x 12" Cooking Surface





eurodib

CEBIF4

CGBIP4

Krampouz® Crepe Makers

- Heavy-duty cast iron cooking surface provides uniform heat distribution
- Thermostatic controls allow for precise temperature adjustments
- Durable stainless steel construction for commercial kitchen environments
- 251° to 1061°F temperature range

Electric

- Coiled heating elements maintain constant temperature for consistent results

Gas

- Integrated thermocouple safety device automatically cuts gas supply

ELECTRIC	GRIDDLE SIZE	DIMENSIONS	POWER
CEBIR4	16" dia	20" w x 5" h	120V
CEBIF4	15¼" dia	17⅞" dia x 6⅞" h	208/240V
GAS			
CGBIP4	16" dia	19" dia x 7¾" h	24,000 BTU



PGT14

Bottom platen has a patented splash guard

PRO-MAX® Panini Grills

- Analog temperature controls with grooved or smooth plates
- Heavy-duty aluminum platens
- Heavy-duty commercial hinge system and handle
- Ergonomically designed control panel provides easy access and visibility to controls and grease drawer
- 120V
- 16½" w x 23⅞" d x 10½" h
- Made in USA
- Models available with other plate configurations



GROOVED	SMOOTH
PGT7	PST7
PGT14	PST14
6½" x 13⅞" Cook Surface	6½" x 13⅞" Cook Surface
13½" x 13½" Cook Surface	13½" x 13½" Cook Surface

nemco | FOOD EQUIPMENT

PaniniPro™ High-Speed Sandwich Presses

- Dual heating technology
- Nonstick coating on all food-contact surfaces and flexible spatula included for easy removal of sandwiches
- 8 push-button electronic controls and digital display make operation extremely simple
- Built-in USB port, flash drive and software included for easy programming
- 14½" w x 26½" d x 23½" h
- 10½" x 10½" heating surface accommodates 4 standard-sized Texas toast sandwiches
- 1-year parts and labor warranty



6900A-208-FF/6900A-240-FF

	TOP/BOTTOM PLATES	VOLTAGE
6900A-208-GF	Grooved/Flat	208V
6900A-208-GG	Grooved/Grooved	208V
6900A-208-FF	Flat/Flat	208V
6900A-240-GF	Grooved/Flat	240V
6900A-240-GG	Grooved/Grooved	240V
6900A-240-FF	Flat/Flat	240V



Cooks sandwiches in about 1 minute



COUNTER EQUIPMENT



Simple push-button control panel



People who serve, products that solve.™

Flip Waffle Maker

- Produces evenly cooked thick Belgian waffles in minutes
- Features a 180° swivel mechanism for even heat distribution
- Simple push-button control panel allows you to adjust the time and temperature for precision cooking
- Easy-to-read LED panel displays time and temperature
- Offers fast heat-up and quick recovery between uses
- Signals the end of a cooking cycle with an audible beeper
- Designed for continuous, everyday commercial use with consistent, repeatable results
- 11¹/₁₆" w x 22³/₁₆" d x 11¹/₁₆" h
- 120V

FWM-1B 7" dia x 1¹/₄" Thick Belgian Waffles



Round Waffle Makers

- Make evenly cooked, 7" round waffles on demand
- Delivers high productivity with fast initial heat up time, excellent heat retention and quick recovery
- Features an exclusive heating element design for exceptional heat distribution
- Offers adjustable time and temperature settings for precise cooking control
- Includes a push-button control panel with an LED display
- An audible beeper signals the end of the cooking cycle
- Constructed with a stainless steel frame and cast aluminum cooking plates
- 17¹/₁₆" d x 8" h
- 120V

	WIDTH	WAFFLE TYPE
RWM-1	9 ⁹ / ₁₆ "	(1) Standard
RWM-1B	9 ⁹ / ₁₆ "	(1) Belgian
RWM-2	19 ⁹ / ₁₆ "	(2) Standard
RWM-2B	19 ⁹ / ₁₆ "	(2) Belgian



People who serve, products that solve.™



Belgian Waffle Maker

- Ergonomic, rotary feature ensures even browning
- One-touch removable waffle plates with PFAS-free non-stick coating
- Stainless steel housing
- Easy-turn dial with adjustable browning, auto shutoff and audible beep
- 9¹/₂" w x 15¹/₂" d x 9⁹/₁₆" h
- 1300W, 120V
- 1-year parts and labor warranty

26700 Produces up to 25 Belgian Waffles per Hour



Belgian Waffle Maker

- 180° rotation evenly distributes batter to produce perfect results every time
- Non-stick cast aluminum plates for quick-release and easy cleaning
- Compact, durable stainless steel construction for high-volume kitchens
- Deep divots produce 1/4" thick waffles ideal for cradling syrup and fruit
- 1000W, 120V

BWM-07 35 Belgian Waffles per hour



Heavy-Duty Cast-Iron Belgian Waffle Maker



- Heavy-duty cast-iron plates provide superior heat retention
- Rotary design evenly distributes batter for consistent browning and texture
- Permanent non-stick coating allows for quick waffle release
- Programmable controls and an audible alert prevent overcooking
- 120V

WWHD500 Up to 30 Waffles/hr



Dough Divider & Rounder

- Semi-automatic; divides and rounds to exact weight
- Automatic rounding with timer
- Great for bread and pizza dough
- 1-year, on-site parts and labor warranty
- 115V, ½ hp

DR11 Makes (11) 11-23 oz Portions
DR14 Makes (14) 4-10 oz Portions



Pizza Spinner/Spreader

- One-of-a-kind dough spinner produces perfectly spun pizza dough in seconds
- Patented micro rolling system spreads dough evenly, giving you the ability to adjust dough thickness
- Execution of the edge
- Automatic start and stop
- 23" w x 25" d x 30" h
- 1-year, on-site parts and labor warranty

SPZ40 15¾" Spinner



6800A-B

Removable crumb tray

Consistency in every batch.



ToasterPRO Conveyor Toasters

- Heavy-duty stainless steel construction
- Consistent high-volume throughput
- Adjustable heat settings for toasting a variety of breads and bakery products
- Cool-touch exterior for safe operation
- 14½" w x 19¼" d x 16½" h
- 300 slices per hour
- 120V

6800A Stainless Steel
6800A-B Powder Coated, Black



COUNTER EQUIPMENT

Bun Grill Toaster

- Stainless steel construction with nickel-plated steel griddle plate
- Patented "self-leveling" conveyor
- Adjustable speed for your desired toasted bun surface and bun internal temperatures
- Butter roller and pan consistently covers buns with the perfect amount of butter
- Fast heat-up allows your operation to react to surges in volume
- 1-year limited parts and labor warranty
- 120V

M-95-2 Up to 865 Bun Halves/hr



Automatically adjusts to various sizes of bread



Built for the rush.

Spectrum™ Conveyor Toasters

- Heavy duty all stainless steel "Cool-Touch" exterior
- Large 2½" high feeder opening with a 10%" (2-slice) wide conveyor that accepts over-sized bagels and Texas Toast
- Extra-wide, curved, front-return chute prevents larger foods from getting caught
- Variable conveyor-speed dial control for optimal doneness
- Choose between independent or dual-heating elements for added flexibility
- Hold mode saves up to 75% energy during slow periods when unit is not in use and allows quick recovery to temperature
- 14" w x 16" d x 16" h
- 1-year parts and labor warranty

ECT-300 300 Slices/hr, 1700W, 120V
ECT-700 700 Slices/hr, 1800/2400W, 208/240V



ECT-300

Cool-touch exterior for safe operation



AT Express Conveyor Toaster

- All stainless steel construction with a "cool-touch" insulated top
- Extended super feeder and warming area to allow for high volume production
- Unique warming area keeps toast at the perfect temperature until you are ready to serve
- Small footprint fits into tight counter space
- Self-dispensing bread drawer slides forward for removal of product
- 14" w x 17" d x 13" h
- 120V

AT EXPRESS 300 Slices/hr





Features an ergonomic magnetic handle

MULTI.Day Hot Vacuum

- Vacuum seals hot food in under 75 seconds
- Optimized for use with EVEREO® for Service Temperature Food Preserving
- Seals food directly inside MULTI.Day trays
- Integrated vacuum control measures and reports anomalies for a perfect seal
- Features a wide support base for stable use
- 110V, requires a 5-8 bar compressed air inlet
- Hot vacuum trays, lids, bags and accessories sold separately



XUC175 21¼" w x 16½" d x 23¾" h



Vacuum Sealer

- Provides reliable chamber vacuum sealing for solids, liquids and delicate products
- Features a stainless steel body for durability and easy sanitation
- Digital control panel with an LCD screen and multiple programmable settings
- Includes phased vacuum and progressive decompression for packaging soft items
- Equipped with an inert gas flush function for modified atmosphere packaging
- Utilizes a commercial-grade oil pump with a self-maintaining drying program
- Transparent lid allows for clear monitoring of the entire vacuum cycle
- 120V
- 15" w x 18¾" d x 16" h
- Other sizes available

1140758 13" Sealing Bar



Atmovac's Diablo Vacuum Sealing Machines

- In-chamber vacuum sealing, perfect for use with sous vide cooking
- Stainless steel construction
- Features a time-based program
- Machine cycle: 30-40 seconds
- 1-year parts & labor warranty



	SEALING BAR(S)	DIMENSIONS
DIABLO10	(1) 10"	13¾" w x 18¾" d x 14" h
DIABLO12	(1) 12"	14¾" w x 16¾" d x 14" h
DIABLO17D	(2) 17"	19½" w x 22¾" d x 18¾" h
W/GAS INJECTION SYSTEM		
DIABLO20D	(2) 20"	23¾" w x 25¾" d x 40" h

DIABLO10

CHRISPER Station

- Insulated stainless steel construction
- 2 flip up, glass doors with 2 sets of removable wire shelves
- Each shelf can be programmed for a different menu item
- Programmable touchscreen controller with multiple menu settings
- Insulated stainless steel construction
- Precision-engineered heat ducts with a single fan and motor
- (4) 18" x 26" pan capacity (pans not included)
- 208/240V
- 1-year parts and labor warranty



FFS4V-25TI 24¾" w x 34¾" d x 39¾" h



Crisp 'N Hold® Crispy Food Holding Stations

- 1" thick insulated cabinet with efficient circular air flow keeps food hot and crispy
- Adjustable dividers to hold more than 1 product at a time
- Stainless steel construction with a welded cabinet
- Electrical mechanical thermostat
- Factory pre-set temperature of 190°F
- Removable modular forced air heating system, oil filter, collection pan and food grate
- 1" rubber feet
- 29" d x 17¾" h
- 1-year parts & labor warranty

Holds breaded, fried and crispy foods up to 4 times longer



CNH18

CNH14 2 Sections, 14¾" w
CNH18 3 Sections, 17¾" w





TwinTouch™ 4-Stage Microwave Ovens

- Features unique TwinTouch™ dual controls for accessible operation on any shelf
- Stainless steel interior and exterior
- 0.75 cu ft oven fits (1) ½ size or (2) ¼ size pans
- Offers 11 power levels and memory for up to 100 custom programs
- Simplifies high-volume cooking with 4-stage programming and double/triple quantity pads
- Saves counter space with a compact and stackable cabinet design
- Top and bottom microwave energy feed
- Express Defrost™ and counter check
- 17½" w x 13¾" d x 20½" h
- 3-year parts and labor warranty and 3-year magnetron part warranty

RCD1200M	1200W
RCD1800M	1800W
RCD2200M	2200W



Digital 3-Stage Commercial Microwave Ovens

- Heavy-duty commercial microwave built for high-volume foodservice
- Stores up to 20 program inputs for fast, repeatable cooking
- Offers 3-stage programming and Express Defrost™ for menu versatility
- SelectaPower™ provides variable power levels for precise cooking control
- Counter check function tracks usage to monitor kitchen performance
- 20⅞" w x 18½" d x 13¼" h
- 3-year parts and labor and 3-year magnetron part warranty

R22GTF	1200W
R25JTF	2100W



Stainless steel interior and exterior



Medium-Duty Commercial Microwave Ovens

- Delivers 1000 watts of cooking power for medium-duty commercial applications
- Features a 1 cu. ft. capacity that accommodates a half-size food pan
- Stainless steel interior, exterior and door for lasting durability
- 120V
- 20½" w x 16" d x 12⅞" h

R21LCFS	Light Up Dial w/ Auto Cancel, 1-Stage Cooking
R21LVF	Touch Pads w/ Braille, 1-Stage Cooking
R21LTF	Touch Pads w/ Braille, 3-Stage Cooking



Unique, durable squeeze trigger handle





Commercial Microwave

- Stainless steel exterior and interior
- Touchpad controls
- Holds a 14" platter
- Grab & Go handle
- 1.2 cu ft
- 1-year full warranty; 3-year magnetron part only warranty



RCS10TS 1000W



Heavy-Duty Microwave Oven

- Stainless steel interior and exterior
- Top touchpad controls
- 100 programmable menu items
- 11 power levels and 4 cooking stages for cooking flexibility
- Stackable
- 1800W
- 3-year warranty

0.6 cu ft cavity fits a 6" deep ½ size pan

HDC182 16½" w x 21½" d x 13½" h



Light-Duty Microwave Oven

- Stainless steel exterior
- 10 programmable memory pads and 20-memory capability
- 2- and 3-level cooking process—for automatic switching of performance level during cooking
- Touch control keypad with Braille
- Programmed option for X2
- Grab & Go handle
- 0.8 cu ft
- 20½" w x 14½" d x 12" h

NE-1054F 1000W

Heavy-Duty Microwave Oven

- Top and bottom energy feed
- 30 memory programs
- Programmable touch pad control
- 5-stage cooking
- 15 power levels
- Automatic voltage selector
- Patented safety door seal system
- 2 units can be stacked
- Grab & Go handle
- 0.6 cu ft
- 16½" w x 20" d x 13¼" h



NE-17523 1700W



SonicChef High-Speed Convection Multi-Oven

- Convection, broil or microwave can be used individually or in combination into 6 heating patterns
- Stainless steel cabinet, door and cavity
- Ventless design with twin inverters
- Color LCD touch control panel programs and store up to 1,000 menu items
- Maintains cooking temperatures from 350° to 525°F
- Adjustable fan speed
- Can be stacked
- 18½" w x 22¼" d x 16½" h
- 208/240V
- 1-year parts and labor warranty

NE-SCV2NAPR 1200W Microwave, 1150W Convection, 1800W Grill



COUNTER EQUIPMENT



Spectrum™ Touch Control Microwave

- Spacious 0.9 cubic feet interior accommodates a 12" dia platter
- 10 cooking presets built in with 100 settings customizable to your menu
- 5 power levels for precise cooking control
- 2x quantity button allows adjustment for multiple portions
- Stainless steel interior and exterior, and heavy-duty components stand up to daily use
- 20 $\frac{1}{8}$ " x 17 $\frac{1}{8}$ " x 12 $\frac{1}{4}$ "
- 1-year parts and labor warranty



EMW-1000ST 1000W, 120V



Large Capacity Spectrum™ Touch Control Microwave

- Large 1.2 cubic feet interior accommodates a 14" dia platter
- 10 cooking presets built in with 100 settings customizable to your menu
- 5 power levels for precise cooking control
- 2x quantity button allows adjustment for multiple portions
- Stainless steel interior and exterior and reliable heavy-duty components
- 22 $\frac{3}{8}$ " w x 20 $\frac{3}{4}$ " d x 14 $\frac{1}{2}$ " h
- 1-year parts and labor warranty

EMW-2100BT 2100W, 208V



Lincoln



Shown with optional legs and casters

Aperion® Impinger Conveyor Ovens

- Stainless exterior and interior
- Double and triple stackable for ventless operation
- Available in gas, electric or electric ventless for countertop or free-standing applications
- High output elements or burners combined with dual blower motors reduce cook times by 30% versus traditional impingement conveyors
- 20 second to 30 minute cook time
- Front located, easyTouch controls with 20 recipe pre-sets
- Easy one-touch belt direction change
- Optional half pass window door is ideal for slices or other items requiring less cook time
- Front removable door and conveyor belt provide easy access to finger assemblies for cleaning
- 2-year parts and labor factory warranty from the date of install and approved start-up

1624 49" w x 31 $\frac{3}{4}$ " d x 19 $\frac{1}{2}$ " h, 16" w Belt
 2024 49" w x 35 $\frac{3}{4}$ " d x 19 $\frac{1}{2}$ " h, 20" w Belt
 2424 49" w x 39 $\frac{3}{4}$ " d x 19 $\frac{1}{2}$ " h, 24" w Belt
 2824 49" w x 43 $\frac{3}{4}$ " d x 19 $\frac{1}{2}$ " h, 28" w Belt



Sota i1 Rapid Cook Ovens

- Cool-to-the touch, high-temperature, powder coated, corrosion-resistant exterior front and door
- Combines high-speed air impingement and microwave technology for rapid cooking
- Internal catalytic filtration system allows for ventless operation
- Smart Voltage Sensor Technology automatically detects and adjusts to the proper voltage
- Touchscreen controls
- Open kitchen connectivity enabled/available
- Made in USA
- 208/240V
- 19 $\frac{3}{8}$ " w x 31 $\frac{3}{8}$ " d x 25" h
- 12 $\frac{1}{2}$ " x 10 $\frac{1}{2}$ " x 7 $\frac{1}{2}$ " cooking chamber
- 1-year parts and labor warranty

TURBOCHEF



DUAL TEMPERATURE INTERFACE
i1-9500-801 Jet Black
i1-9500-889 Traffic Red
i1-9500-905 Stainless Steel

EL BANDIDO W/ PANINI PRESS
i1-9500-921 Traffic Red
i1-9500-938 Jet Black
i1-9500-973 Stainless Steel



Features an intuitive touchscreen and USB port

Rapid cooking done right.



TURBOCHEF

CIBO+ Rapid Cook Oven

- Delivers high-speed cooking performance with ventless operation
- Features tri-heat technology combining microwave, impinged air and a radiant base
- Utilizes a recirculating catalytic converter to minimize smoke, grease and odors
- Includes a 5" capacitive touchscreen with an 80-item programmable menu
- Stainless steel exterior
- Compact size cooks up to (3) 12" pizzas
- 15 $\frac{1}{2}$ " w x 26 $\frac{3}{8}$ " d x 25 $\frac{1}{2}$ " h
- 208/240V
- 1-year parts and labor warranty



CB0-9500-1 13 $\frac{3}{8}$ " x 13 $\frac{3}{8}$ " x 7 $\frac{1}{8}$ " Cooking Chamber



Features simple touchscreen controls

Bullet Rapid Cook Oven

- Combines radiant, high-speed impingement and microwave energy for rapid cooking
- Ventless operation with a built-in catalytic converter eliminates the need for a commercial hood
- Stores for up to 256 recipes
- Stainless steel interior and exterior
- Open kitchen connectivity enabled/available
- Includes a starter kit with a baking stone, paddle, baskets and cleaning supplies
- 208/240V
- 21 $\frac{1}{2}$ "w x 27 $\frac{1}{2}$ "d x 23"h
- 1-year parts and labor warranty



ENC-9600-801 15 $\frac{1}{2}$ " x 14 $\frac{1}{2}$ " x 6" Cooking Chamber



Double Batch Dual Cavity Impingement Ovens

- Maximizes menu flexibility with 2 independently controlled oven cavities
- Circulates impinged air up to 60 mph to drastically reduce cook times
- Features variable-speed blowers and oscillating racks for consistent, even cooking
- Integrated catalytic converter enables ventless operation
- Stackable design doubles cooking capacity without increasing footprint
- Stainless steel interior and exterior
- Made in USA
- 208/240V (Available in Single or Multi Phase)
- 27 $\frac{1}{8}$ "w x 31 $\frac{1}{8}$ "d x 23 $\frac{3}{8}$ "h
- 18 $\frac{3}{4}$ " x 17 $\frac{1}{8}$ " x 3 $\frac{3}{16}$ " cooking chamber
- 1-year parts and labor warranty



HHD-9500-801	DOORS	2 Glass	PHASE	Single
HHD-9500-814-DL	DOORS	2 Glass	PHASE	Multi
HHD-9500-993	DOORS	2 Solid	PHASE	Single
HHD-9500-994-DL	DOORS	2 Solid	PHASE	Multi

High h Conveyor Ovens

- Accelerates cook times with a variable-speed recirculating impingement airflow system
- Features independently controlled top and bottom air impingement for precise cooking
- Stackable design allows for up to 3 units high to maximize throughput
- Smart Voltage Sensor Technology automatically adapts to 208V or 240V power
- Made in USA
- Additional models available
- 1-year parts and labor warranty

Stainless steel interior and exterior



	PIZZA SIZE	BELT	DIMENSIONS
HCS-9500-511	16"	Single Standard	36"w x 31 $\frac{1}{8}$ "d x 17"h
HCS-9500-512	16"	Single Standard	48"w x 31 $\frac{1}{8}$ "d x 17"h
HCT-9500-501	20"	Single Standard	48 $\frac{3}{8}$ "w x 35 $\frac{3}{8}$ "d x 17"h
HCT-9500-504	20"	50/50 Split	48 $\frac{3}{8}$ "w x 35 $\frac{3}{8}$ "d x 17"h
HCW-9500-501	26"	Single Standard	48 $\frac{3}{8}$ "w x 41 $\frac{1}{8}$ "d x 17"h
HCW-9500-506	26"	50/50 Split	48 $\frac{3}{8}$ "w x 41 $\frac{1}{8}$ "d x 17"h
VENTLESS			
HCS-9500-511-V	16"	Single Standard	36"w x 31 $\frac{1}{8}$ "d x 17"h
HCS-9500-512-V	16"	Single Standard	48"w x 31 $\frac{1}{8}$ "d x 17"h
HCT-9500-501-V	20"	Single Standard	48 $\frac{3}{8}$ "w x 35 $\frac{3}{8}$ "d x 17"h
HCT-9500-504-V	20"	50/50 Split	48 $\frac{3}{8}$ "w x 35 $\frac{3}{8}$ "d x 17"h
HCW-9500-501-V	26"	Single Standard	48 $\frac{3}{8}$ "w x 41 $\frac{1}{8}$ "d x 17"h
HCW-9500-506-V	26"	50/50 Split	48 $\frac{3}{8}$ "w x 41 $\frac{1}{8}$ "d x 17"h

Dual conveyor system



Lincoln



Digital Impinger Ovens

- Countertop conveyor oven delivers large-oven capacity in a small footprint
- Utilizes air impingement for uniform cooking and fast, consistent results
- Stainless steel top, front and sides
- Ventless design allows for flexible placement and reduces installation costs
- Features a dual voltage design for automatic power conversion
- Conveyor speed adjusts from 30 seconds to 15 minutes for menu versatility
- Adjustable temperature range from 90° to 600°F
- Digital controls feature reversible conveyor direction, manual override, variable speed control and temperature settings with 4 pre-set menu buttons
- 18-month parts and labor warranty



V2500/1353 35 $\frac{3}{8}$ "w x 31 $\frac{3}{8}$ "d x 18"h, 31"l x 16"w Conveyor
 V2500/1346 35 $\frac{3}{8}$ "w x 31 $\frac{3}{8}$ "d x 18"h, 50"l x 16"w Extended Conveyor



Stackable design allows units to be placed two high to maximize footprint

Ventless design for flexible placement.



PSS20G-1



X20G-1

Impingement Conveyor Ovens

- Bake pizzas, pastas, fajitas and steaks
- Vertical columns of hot air offer rapid, consistent cooking
- Features microprocessor controls for precise bake time and conveyor speed
- The 42"l x 18"w conveyor moves through a 20" baking chamber with a reversible feature that allows it to fit different kitchen layouts
- Reaches operating temperatures up to 600°F
- Adjustable bake times range from 1 to 12 $\frac{1}{2}$ minutes
- Stackable up to 3 units high for maximum production
- Gas models have 40,000 BTU per oven
- 208/240V
- 42"l x 37 $\frac{1}{8}$ "d



GAS		ELECTRIC	
PSS20G-1	Single, 21 $\frac{1}{8}$ "h	PSS20E-1	Single, 21 $\frac{1}{8}$ "h
PSS20G-2	Double, 36 $\frac{1}{8}$ "h	PSS20E-2	Double, 36 $\frac{1}{8}$ "h
PSS20G-3	Triple, 52 $\frac{3}{8}$ "h	PSS20E-3	Triple, 52 $\frac{3}{8}$ "h

Countertop Conveyor Ovens

- Delivers rapid, consistent baking with a variable-speed recirculating impingement airflow system
- Features a patent pending compact gas heat system for efficient performance
- Equipped with a 20" long cooking chamber and 48" long conveyor belt
- Offers precise control with variable-speed blower motors and reversible belt direction
- Includes built-in self diagnostics for simplified component monitoring
- Stackable design up to 2 units high to maximize production capacity
- Gas models have 40,000 BTU per oven
- 208/240V
- 48 $\frac{3}{8}$ "w
- 2-year parts and labor warranty

GAS		ELECTRIC	
X20G-1	Single, 38 $\frac{1}{8}$ "d x 17"h	X20E-1	Single, 35 $\frac{3}{8}$ "d x 17"h
X20G-2	Double, 38 $\frac{1}{8}$ "d x 31"h	X20E-2	Double, 35 $\frac{3}{8}$ "d x 31"h



COUNTER EQUIPMENT



PM 351ED-1

PizzaMaster®

Multi Purpose Ovens

- Stainless steel exterior
- Features a single or multiple ceramic clay hearthstones per chamber for fast heat recovery and crispy crusts
- Reaches a maximum baking temperature of 752°F for rapid cooking
- Includes an IQControl Panel™ with TurboStart function for faster heat-up
- Utilizes 2-zone heating elements for even baking across the entire deck
- Built with a durable and easy-to-clean stainless steel front
- 2-year limited warranty

Clear product visibility with large windows and dual interior lighting



PM 552ED-4

STANDARD	CHAMBER(S)/DECKS	CAPACITY	DIMENSIONS
PM 552ED-4	2/4	(4) 20" Pizzas	23 $\frac{3}{8}$ "w x 21 $\frac{1}{2}$ "d x 19 $\frac{1}{2}$ "h
PM 351ED-1	1/2	(2) 16" Pizzas	30 $\frac{1}{2}$ "w x 28 $\frac{1}{2}$ "d x 31 $\frac{1}{2}$ "h
DOUBLE WIDE			
PM 452ED-2DW	2/4	(4) 20" Pizzas	41 $\frac{1}{8}$ "w x 23 $\frac{3}{8}$ "d x 19 $\frac{1}{2}$ "h
PM 401ED-1DW	1/2	(2) 16" Pizzas	45 $\frac{1}{8}$ "w x 25 $\frac{1}{2}$ "d x 31 $\frac{1}{2}$ "h



PM 452ED-2DW

Big flavor. Small footprint.



**Hearthbake Series
Pizza/Pretzel Ovens**

- Single or double cooking/baking chambers
- Stainless steel exterior
- Unitized, welded, aluminized steel interior
- Temperature range of 284° to 680°F
- Deck(s) are 3/4" h
- Units available in 208, 220 or 240V



Electric minute timer with continuous ring alarm

SINGLE BAKE	CHAMBER SIZE	DECK SIZE
P18S	22 1/4" w x 17 1/2" h	(2) 17 3/4" w x 17 1/2" d
P22S	26" w x 17" h	(2) 20 3/4" w x 20 3/4" d
DOUBLE BAKE		
P44S	26" w x 28 1/2" h	(4) 20 3/4" w x 20 3/4" d

Space-saving pizza power.



Electric Pizza Oven

- Dual independently controlled heating elements quickly and evenly bake pizza, breadsticks, and more
- Heats and maintains temperature up to 600°F
- Includes a 60-minute timer with done bell and a stay-on function for extended heating
- Crumb tray slides out for easy cleaning
- 1500W, 120V
- 20 3/8" w x 14 3/4" d x 9 1/4" h
- 1-year parts and labor warranty



EP0-1 Holds (1) 12" pizza



COUNTER EQUIPMENT



Liner protects the oven cavity



Easy to install. Covers the oven door and side walls - simplifying cleaning.

MERRYCHEF

Oven Cavity Liner

- Fits Merrychef conneX®12 and eikon®e2s
- Significantly reduces labor with just 2 surfaces to clean
- 90% reduction in chemical usage
- Withstands high heat applications up to 602°F
- Blue color highlights food debris

PSY183

25 $\frac{1}{2}$ "w x 17 $\frac{1}{2}$ "d



MERRYCHEF

Cooks up to 80% faster than standard cooking methods



CONNEX 12 HP



CONNEX 16



conneX® High Speed Ovens

- All-in-one unit for cooking, toasting, grilling and reheating fresh or frozen food
- Triplex technology combines convection, impingement and microwave heat
- Ventless catalytic converter makes it suitable for front of the house use
- Easy operation with a 7" wide high definition display and easyTouch® 2.0 controller

CONNEX 12 HP
CONNEX 16

14" w x 25 $\frac{1}{2}$ "d x 24 $\frac{3}{4}$ "h, 12" x 12" Oven
18 $\frac{1}{2}$ "w x 26 $\frac{1}{2}$ "d x 24 $\frac{3}{4}$ "h, 16" x 16" Oven



VULCAN



Chef'sCombi™ Half Size Combi Ovens

- Features the intuitive GlobalOS operating system on a 10" HD touchscreen
- Chef'sGuide automatic cooking and MenuMix smart technology streamline production
- Manages humidity with CombiClimateControl for precise cooking environments
- Programmable automatic cleaning cycles
- Stainless steel interior and exterior
- Connects via Ethernet, USB or the SmartConnect app for recipe and HACCP data management
- Features a double-glazed, heat-reflective door for energy efficiency
- Holds (6) 12" x 20" hotel pans or (6) 13" x 18" half sheet pans
- 2-year limited parts and labor warranty

CHEF-61E Electric, 208/240/480V
CHEF-61G Gas, 58,006 BTU

Features LED temperature display, glass door and halogen lights

TWO UNITS SHOWN WITH OPTIONAL STACKING KIT AND SPRAY HOSE

VULCAN

Combi Oven/Steamers

- Full size, boilerless oven with 3 easy-to-use temperature knobs
- Bake, steam, roast, air-fry, rethermalize, proof, finish poaching, stew, low temp and defrost with one piece of equipment
- Stainless steel interior and exterior
- Auto-sets optimal humidity based on temperature and time
- Auto-reversing fan with electronic braking system
- Includes (4) wire racks - holds (7) 18" x 26" or (14) 12" x 20" pans
- 42 $\frac{1}{4}$ "w x 43 $\frac{1}{2}$ "d x 35" h
- 1-year limited parts and labor warranty

ABC7E Electric, 208V
ABC7G Gas, 80,000 BTU



Kitchen equipment that measures up.

Welcome to next-level baking.

CHEFTOP-X™ Digital.ID™ Countertop Combi Ovens

- Features the Digital.ID™ advanced operating system with intelligent cooking technology
- Type 316 stainless steel chamber for maximum corrosion resistance
- Maintains precise cooking temperatures from 86° to 572°F
- Operates via an intuitive 16" LCD touch panel with HEY.Unox voice recognition
- Utilizes ADAPTIVE.Cooking, STEAM.Maxi, and AIR.Maxi technologies for uniform results
- Includes WiFi and USB connectivity with storage for over 1,000 recipe programs
- Equipped with a SENSE.Klean automatic cleaning system and RO.Care water filtration
- Electric models require a 208V/240V, 3 phase electrical connection for operation

ELECTRIC

- XADA-0611-EXRS** Holds (6) 12" x 20" Pans, 29 $\frac{1}{2}$ "w x 33 $\frac{1}{2}$ "d x 31 $\frac{1}{2}$ "h
- XADA-1011-EXRS** Holds (10) 12" x 20" Pans, 29 $\frac{1}{2}$ "w x 33 $\frac{1}{2}$ "d x 43 $\frac{1}{2}$ "h
- XADA-06FS-EXRS** Holds (6) 18" x 26" Pans, 33 $\frac{1}{2}$ "w x 40 $\frac{1}{2}$ "d x 33 $\frac{1}{2}$ "h
- XADA-10FS-EXRS** Holds (10) 18" x 26" Pans, 33 $\frac{1}{2}$ "w x 40 $\frac{1}{2}$ "d x 47 $\frac{1}{2}$ "h

GAS

- XADA-0611-GXRS** Holds (6) 12" x 20" Pans, 29 $\frac{1}{2}$ "w x 33 $\frac{1}{2}$ "d x 31 $\frac{1}{2}$ "h, 51,180 BTU
- XADA-1011-GXRS** Holds (10) 12" x 20" Pans, 29 $\frac{1}{2}$ "w x 33 $\frac{1}{2}$ "d x 43 $\frac{1}{2}$ "h, 85,300 BTU
- XADA-06FS-GXRS** Holds (6) 18" x 26" Pans, 33 $\frac{1}{2}$ "w x 40 $\frac{1}{2}$ "d x 33 $\frac{1}{2}$ "h, 91,214 BTU
- XADA-10FS-GXRS** Holds (10) 18" x 26" Pans, 33 $\frac{1}{2}$ "w x 40 $\frac{1}{2}$ "d x 47 $\frac{1}{2}$ "h, 136,480 BTU



XADA-1011-GXRS



XADA-06FS-GXRS



SPEED.Pro™ Commercial Baking Speed Ovens

- Utilizes convection, conduction and microwave heat from 86° to 500°F
- Features DRY.Plus humidity extraction and AIR.Plus reversing fans for uniform results
- Includes ADAPTIVE.Cooking and SMART.Preheating for automated, intelligent performance
- Stainless steel oven can accommodate 3 half size sheet pans
- Offers an intuitive touch control panel with WiFi and USB connectivity
- Designed for ventless, countertop operation
- Also available in 3 Phase
- 23 $\frac{3}{8}$ "w x 31 $\frac{3}{8}$ "d x 21 $\frac{1}{2}$ "h
- 240V

XASR-03HS-SDDS 1 Phase

Combines speed oven and convection baking in one unit



CHEFTOP MIND.Maps™ Countertop Plus Combi Ovens

- AIR.MAXI technology ensures perfect distribution of air and heat within the cooking chamber
- 4 air speeds and 4 semi-static modes perfectly cook a variety of menu items
- ADAPTIVE.Cooking technology interprets your settings and registers variations in humidity and temperature
- Stainless steel interior and exterior
- 9 $\frac{1}{2}$ " touch control panel
- Left hinged doors, models available with right hinged doors

ELECTRIC

- XAVC-0511-EPRM** Holds (5) 12" x 20" Pans, 29 $\frac{1}{2}$ "w x 31 $\frac{1}{2}$ "d x 26 $\frac{1}{2}$ "h
- XAVC-06FS-EPRM** Holds (6) 18" x 26" Pans, 33 $\frac{1}{2}$ "w x 38 $\frac{1}{2}$ "d x 33 $\frac{1}{2}$ "h
- XAVC-1011-EPRM** Holds (10) 12" x 20" Pans, 29 $\frac{1}{2}$ "w x 31 $\frac{1}{2}$ "d x 39 $\frac{3}{4}$ "h
- XAVC-10FS-EPRM** Holds (10) 18" x 26" Pans, 33 $\frac{1}{2}$ "w x 38 $\frac{1}{2}$ "d x 45 $\frac{1}{4}$ "h

GAS

- XAVC-0511-GPRM** Holds (5) 12" x 20" Pans, 29 $\frac{1}{2}$ "w x 31 $\frac{1}{2}$ "d x 26 $\frac{1}{2}$ "h, 51,182 BTU
- XAVC-06FS-GPRM** Holds (6) 18" x 26" Pans, 33 $\frac{1}{2}$ "w x 38 $\frac{1}{2}$ "d x 33 $\frac{1}{2}$ "h, 81,891 BTU
- XAVC-1011-GPRM** Holds (10) 12" x 20" Pans, 29 $\frac{1}{2}$ "w x 31 $\frac{1}{2}$ "d x 39 $\frac{3}{4}$ "h, 75,067 BTU
- XAVC-10FS-GPRM** Holds (10) 18" x 26" Pans, 33 $\frac{1}{2}$ "w x 38 $\frac{1}{2}$ "d x 45 $\frac{1}{4}$ "h, 119,424 BTU



ELECTRIC



GAS



COUNTER EQUIPMENT



XpressChef® 4i Series Ventless High Speed Combination Oven

- Turn a small space into a high-production kitchen
- Menu management app, wifi, ethernet and smart USB
- 1200+ programmable settings
- 7" True-Touch™ HD capacitive touchscreen color LCD
- Toast, grill, bake, steam and roast
- No ventilation required
- Removable air filters with cleaning reminder
- Single-position removable rack can hold up to a 14" pizza
- 3000W infrared radiant
- 2000W impingement
- 25 $\frac{1}{8}$ " w x 27 $\frac{1}{2}$ " d x 20 $\frac{3}{8}$ " h

XpressChef

MXP22TLT 2200W



XpressChef® 2c Series High Speed Ventless Baking Oven

- Make perfectly baked goods in a fraction of the time
- Accommodates a 12" pizza
- Menu management app, USB connectivity standard
- 100 programmable settings
- 2.8" full-color LCD HD display
- Non-removable air filter with cleaning reminder
- Ergonomic lift & pull handle
- Ten control touch pads
- Multilingual, supporting 20 languages
- 1900W, 2700W convection
- 19 $\frac{1}{4}$ " w x 26 $\frac{1}{2}$ " d x 18 $\frac{1}{8}$ " h

Perfectly baked goods in minutes

XpressChef



JET19V 1900W

The perfect combination of quality & speed.

SPEED-X™ Digital.ID™ Commercial Combi Speed Ovens

- Self-washing combi speed oven combines convection, steam and microwave cooking
- Stainless steel oven interior
- Operates with the Digital.ID™ system through a 16" interactive touch panel
- Utilizes HYPER.Speed and MULTI.Time technologies for accelerated, simultaneous cooking
- Integrated ROTOR.Klean automatic washing system with SENSE.Klean dirt sensing
- WiFi connectivity enables access to Data Driven Cooking (DDC) analysis and recipes
- Holds (5) $\frac{2}{3}$ size trays
- 240V, 3 Phase
- 21" w x 29" d x 31" h

XAPA-0523-EXRS
XAPA-0523-EXLS

Left Hinged Door
Right Hinged Door



XAEC-1011-EPR



XAEC-1013-EPR

Evereo® Hot Fridges

- Preserves cooked food at serving temperature for days
- Maintains food quality with accurate temperature and atmospheric control
- Features an intuitive 9 $\frac{1}{2}$ " touch control panel for simple operation
- 208 or 240V
- 2-year parts and labor warranty

HOLDS (10) HALF SIZE TRAYS

XAEC-10HS-EPR Left Hinged Door, 23" w x 23" d x 24" h
XAEC-10HS-EPD Drop Down Door, 23" w x 23" d x 24" h

HOLDS (10) FULL SIZE TRAYS

XAEC-1011-EPR Left Hinged Door, 29" w x 24" d x 36" h
XAEC-1011-EPL Right Hinged Door, 29" w x 24" d x 36" h
XAEC-1013-EPR Left Hinged, 21" w x 34" d x 36" h



MOFFAT

Maintains precise temperatures from 150° to 500°F

Turbofan® 30D Series Gas Convection Oven

- Stainless steel exterior and legs with porcelain enameled oven interior and dual oven lamps
- Holds 5 full size sheet pans
- 33,000 BTU/hr patented infrared burner system
- Features digital controls with a large ¾" high LED display
- Bi-directional reversing fan system
- Includes a water injection key to introduce moisture into the oven cavity
- 20 programs with 3 stage cooking and stage end alarms
- Safe-Touch vented side hinged door and stay-cool door handle
- 110/120V

G32D5 28½" w x 31¼" d x 35½" h



E23M3

Turbofan® 20 Series Electric Convection Ovens

- Stainless steel exterior and adjustable feet
- Porcelain enameled oven interior
- Single (E22M3) or bi-directional (E23M3 & E27M3) fan system
- Holds 3 half size or full size sheet pans
- Dual pane glass door and interior lighting
- Safe-Touch vented drop down door with stay-cool door handle
- Manual mechanical thermostat controls
- Maintains temperatures from 150° to 500°F

MOFFAT

	PAN CAPACITY	DIMENSIONS	VOLTAGE
E22M3	3 Half	24" w x 25" d x 27¼" h	110/120V
E23M3	3 Half	24" w x 23¼" d x 25¼" h	208/240V
E27M3	3 Full	31¼" w x 23¼" d x 30" h	208/240V



Turbofan® 20D Series Electric Convection Oven

- Stainless steel construction with enamel oven interior and dual oven lamps
- Holds 4 full-size sheet pans
- Digital mechanical thermostat maintains temperatures from 150° to 500°F
- Features twin bi-directional reversing fans
- Manual mode and 20 programmable, 3-stage and stage end alarms
- Safe-Touch vented drop down door with stay-cool door handle
- 208/220/240V

E28D4 31¼" w x 30" d x 26" h

MOFFAT

TIP

Small Footprint, Big Performance

When selecting a countertop oven, focus on consistent heat distribution, precise temperature control and durable construction. Choosing the right type, size and capacity ensures it meets your establishment's needs without sacrificing performance or workflow efficiency. Once you've selected your oven, keeping it properly maintained will help ensure consistent cooking performance, energy efficiency and longer equipment life.

1. Clean daily after use
2. Inspect and clean fan blades
3. Wipe door gaskets
4. Check temperature accuracy
5. Wipe down exterior surfaces
6. Schedule routine servicing





Sous Vide Immersion Circulator

- Delivers precise temperature control for consistent sous vide cooking
- Maintains temperatures from 41° to 203°F with ±0.1°F accuracy
- Features a 1800W heating element for rapid heating in baths up to 21 gallons
- Circulates 2.6 gallons per minute for uniform temperature and edge-to-edge cooking
- Offers intuitive control via a 5" LCD touchscreen and a Wi-Fi enabled mobile app
- Stainless steel construction
- IPX7 waterproof
- 120V
- 1-year parts & labor warranty

GSV18 5½" w x 7" d x 12½" h



Precise temperature for maximum results.



Visvardis Turbo Gas Shawarma & Gyro Machines

- Solid construction, aesthetic design and reliable performance
- Offers consistent, high-volume vertical roasting
- Imported from Greece for authentic performance
- Bottom-mounted motor design protects internal components from heat
- Patented movable rear heating elements offer precise cooking control
- Individual burner controls for even heating
- Removable drip tray and protection mesh
- 1-year warranty

DG16VN



CLASSIC	CAPACITY	DIMENSIONS	BTU
DG6AN	66-100 lb	20½" w x 25¼" d x 32½" h	36,000
DG8AN	90-140 lb	21½" w x 26¼" d x 39" h	48,000
DG12VN	101-200 lb	23" w x 27" d x 33" h	72,000

TURBO	CAPACITY	DIMENSIONS	BTU
DG16VN	101-200 lb	23" w x 27" d x 41" h	96,000



For daily cleaning of Merrychef high-speed ovens



Oven Cleaning Kit

- Includes 20 individually wrapped tablets and a 24 oz bottle with trigger head for easy application
- Eliminates single-use plastic bottles of cleaning liquid
- Concentrated tablet simplifies portion control
- Removes tough, baked-on food messes without damaging the oven

3224222

MERRYCHEF



Sous Vide Cooker

- Precisely cooks in tanks up to 14 gal
- Intuitive touchscreen simplifies temperature and time control
- Stainless steel body withstands heavy commercial use
- Bluetooth connectivity allows for HACCP data tracking
- Temperature range from 41° to 203°F
- 120V

1180123

4" w x 5½" d x 14½" h





Evolution™ Electric Steamers

- Steamer cavity constructed of reinforced stainless steel
- Cook and variable temperature hold modes
- Easy-to-use digital controls with digital temperature display
- Front-mounted drain valve
- Heavy-duty, field-reversible door
- Cast aluminum heating element is not exposed to water
- Dishwasher-safe one piece wire pan racks, SVT steam collector and distributor panels
- Holds 12" x 20" x 2½" pans
- 1-year parts & labor warranty
- Backed by the industry's ONLY Lifetime Service and Support Guarantee



CONNECTIONLESS	CONNECTED	DECK(S)	PAN CAPACITY	UL LISTED	ENERGY STAR
E6****D100	E6***E100	Single	6	UL LISTED	ENERGY STAR
E6****D100 DBL	E6***E100 DBL	Double	12	UL LISTED	ENERGY STAR
E6****D100 SGL†	E6***E100 SGL†	Single	6	UL LISTED	ENERGY STAR

Replace **** with Voltage & Phase, i.e. 2083
†Comes with Stand



Evolution™ Natural Gas Steamers

- Cook and variable temperature hold mode
- Steamer powered by a heavy-duty stainless steel blue flame power burner rated at 50,000 BTU
- Easy-to-use digital controls, with digital temperature display
- Steamer cavity constructed of reinforced stainless steel
- Dishwasher-safe SVT steam collector and distributor panels
- Front-mounted condensate tray
- Holds 12" x 20" x 2½" pans
- 1 year parts & labor warranty
- Backed by the industry's ONLY Lifetime Service and Support Guarantee



12"-PAN, CONNECTIONLESS DOUBLE

CONNECTIONLESS	CONNECTED	DECK(S)	PAN CAPACITY
N6120ID100	N6120IE100	Single	6
N6120ID100 DBL	N6120IE100 DBL	Double	12
N6120ID100 SGL†	N6120IE00 SGL†	Single	3

†Comes with Stand

Locks in moisture and flavor.



Heavy-Duty Steamer Oven

- Stainless steel interior and exterior
- 1.6 cu ft cavity fits (2) 4" deep full size pans
- Touch pad controls
- USB port compatible with standard flash drives
- 11 power levels
- Stackable
- 25½" w x 23½" d x 18½" h
- 3-year warranty

100 programmable menu items



AMS022 2200W



nemco® FOOD EQUIPMENT

Fresh-O-Matic® Food Steamer

- Stainless steel outer wrap
- Rethermalizes precooked foods with super-hot steam
- Push-button controls and highly visible indicator lights
- Includes a sealed, seamless water reservoir
- Generates steam hotter than 212°F
- 120V, 1500W



6625B 16½" w x 12" d x 11½" h



COUNTER EQUIPMENT



SteamChef 6 Booster Electric Boilerless Convection Steamer

- High-speed electric convection steamer with a boilerless design
- Stainless steel compartment door and latch
- Holds (6) 12" x 20" x 2½" steam pans
- Features a 5" easyTouch control with individual timers and pre-set recipes
- Patented KleanShield™ design collects and removes condensation
- Utilizes an aluminum-encased heating element
- Maintains ideal water levels automatically
- 4" adjustable legs with flanged feet
- 208/220/240V

Cleveland

22CET6.2 21⅝" w x 34⅞" d x 30¾" h



High-Speed Steamer

- Heavy-duty stainless steel cabinet and 1.6 cu ft cavity
- Programmable touch pad control with 16 presets
- 4 power levels
- 2-level cooking
- Positive action dial control timer
- Program lock allows one-touch operation
- 29⅞" w x 20¾" d x 18⅞" h

Panasonic



NE-3280 3200W

One touch operation.

Only 4½ minutes to preheat to 350°F



Star-Max® Electric Fryers

- Lift-out nickel plated kettle
- Stainless steel cabinets
- Adjustable high-limit safety thermostat
- 4" legs
- 208/240V
- 2-year warranty



SINGLE POT	OIL CAPACITY	DIMENSIONS
301HLF	15 lb	18" w x 20" d x 17" h
514LL	14 lb	11⅝" w x 21⅝" d x 13⅝" h
515F	15 lb	12" w x 24" d x 16¾" h
530FF	30 lb	24" w x 24⅞" d x 16½" h
TWIN POT		
530TF	30 lb	24" w x 24" d x 16¾" h



Battered and fried to perfection.



SE-ECFR16



SE-ECFR32



Power and ready indicator lights

WDF1700

Electric Fryers

- Features an adjustable thermostat for precise temperature control up to 370°F
- Stainless steel housing provides durability and simplifies cleaning
- Includes a welded, removable oil pan for easy maintenance
- Comes standard with a night cover and fryer basket(s)
- 110V
- 16¾" d x 13½" h
- 1-year parts and labor warranty

SE-ECFR16
SE-ECFR32

Single, 16 lb Oil Capacity, 12" w
Double, 32 lb Oil Capacity, 25" w



Heavy-Duty Deep Fryers

- Stainless steel exterior, fry baskets and front-mounted drain spigot
- Maintains temperature from 170° to 390°F and a 60-minute countdown timer
- 2 wire fry baskets with removable and ergonomic, cool-touch handles
- Designated cold zones
- Non-skid rubber feet
- 11½" w x 20¾" d
- 120V
- 1-year limited warranty



WDF1300
WDF1700

10 lb Oil Capacity, 17½" h
15 lb Oil Capacity, 19½" h



630FF



Star-Max® Gas Fryers

- Underfired gas countertop design delivers maximum performance
- Features high-power in-shot burners for fast temperature recovery
- Utilizes a single-pot nickel-plated steel kettle for durability
- Copper-plated fins provide even heat distribution and optimal heat transfer
- Maintains precise temperatures from 200° to 375°F with a snap-action thermostat
- Includes an automatic pilot light for quick and easy ignition
- Offers a convenient front-access drain valve for easy oil removal
- Comes standard with 2 chrome-plated steel mesh hanging baskets
- 25½" d x 23½" h
- 2-year parts and labor warranty

615FF Twin Baskets, 15 lb Oil Capacity,
12" w, 30,000 BTU
630FF Full Baskets, 30 lb Oil Capacity,
24" w, 70,000 BTU



TIP

Compact Power, Crispy Results

Ideal for appetizers, fries, wings and small-batch frying, commercial countertop fryers deliver dependable performance while saving valuable kitchen space. Common features include:

- Compact countertop design
- Stainless steel construction
- Oil capacities ranging from 10 to 30 lb
- Lift-out heating elements for easy cleaning
- Adjustable thermostat controls
- Removable fryer baskets
- Safety features such as high-limit protection
- Non-skid feet for stability



COUNTER EQUIPMENT



WRC60

Commercial Rice Cooker/Warmers

- Prepares large-volume batches of rice, grains and soups
- Insulated, double-wall stainless steel construction
- Automatically holds food at ideal serving temperatures
- Heavy-duty, PFAS-free ceramic-coated inner pot
- Brushed finish
- 1-year limited warranty



WRC40

WRC40 40 cups Cooked Rice, 1600W
WRC60 60 cups Cooked Rice, 1800W



Commercial Rice/Grain Cooker

Panasonic

- Push button controls
- Automatically switches to keep-warm mode for up to 5 hours
- Includes a non-stick, Teflon coated inner pan to prevent burning
- Silver finish
- Includes a rice scoop and measuring cup
- 16 $\frac{1}{2}$ "w x 14 $\frac{1}{2}$ "d x 14 $\frac{1}{2}$ "h
- 120V, 1800W
- 1-year parts and labor warranty



SR-GA541FH 60 cups Cooked Rice



HATCO
 People who serve, products that solve.™

Palleti® Induction Warmers

- Elegant, contemporary, low-profile design with a bold black housing and durable, black glass-ceramic top that is easy to clean
- Pan Sense Technology (PST) activates the unit only when a suitable pan is placed on top
- Automatic shut-off to prevent overheating
- Features a control panel with a standby key, temperature control arrow keys and temperature setting indicators
- IWRM-CD1-03 can be interconnected with multiple units
- Low wattage warmers

	WIDTH	TYPE	POWER
IWRM-CD1-03	13"	Countertop	120V/360W
IWRM-C1-1317-06	13"	Countertop	120V/600W
IWRM-B1-1313-06	13"	Drop In	120V/600W



EICS-18

Spectrum™ Induction Cookers

Winco

- Stainless steel body construction
- Easy to use, digitally-controlled wattage and temperature from warming to cooking for optimal cooking efficiency, control and speed
- High-impact and high-heat resistant 11 $\frac{3}{8}$ " x 11 $\frac{3}{8}$ " glass-ceramic cooking surface
- Accommodates pan sizes from 4 $\frac{1}{2}$ " to 10 $\frac{1}{2}$ " dia
- Small-article and pan detection
- Timer up to 150 minutes
- Auto safety shut-off

EICS-18* 1800W, 120V
EICS-34^ 3400W, 240V

*EICS-18 ETLus
 ^EICS-34 cETLus, ENERGY STAR™



EICS-34





Features a high-strength aluminum shell

Dry Soup Wells

- Rethermalize and hold soups or sauces with a waterless design that simplifies cleanup and maintenance
- Utilizes dry conductive heating to rethermalize and hold food without water or plumbing
- Features a high-strength aluminum shell with a stainless steel top ring for durability
- Offers precise temperature management with a touchscreen, 6 presets and 4 custom programs
- Includes an adjustable stir timer and screen lock feature for enhanced control
- Automatically transitions from rethermalization to hold mode
- Accommodates any standard-sized soup pan
- Available in countertop or built-in models
- 120V

COUNTERTOP	CAPACITY	WATTAGE
SWC-7QT	7 qt	425W
SWC-11QT	11 qt	675W
BUILT-IN		
SWB-7QT	7 qt	425W
SWB-11QT	11 qt	675W



Maskerade® Undercounter Induction Warmer

- Provides undercounter induction warming for a clean, seamless countertop presentation
- Mounts invisibly under a wide variety of engineered or natural stone materials
- Offers 5 precise low- to high-power warming levels for different food types
- Features Pan Sense Technology (PST) to activate only when a pan is present
- Includes an automatic shut-off safety feature to prevent overheating
- Retains the last-used power setting in memory for simple start-up
- Comes with a remote control panel for easy temperature management and locking
- Includes a flexible, slip-resistant trivet to protect countertop surfaces
- 15½" w x 15" d x 3½" h

IWRM-UT-05 120V/500W



ThermalPRO Fried Food Holder

- Stainless steel build resists corrosion and wear
- ThermalBreeze™ technology keeps fried food crispy
- Dual safety system ensures reliable operation
- 120V

6075 22¾" w x 16½" d x 7½" h



Removable pan divider



Electric Soup Kettle Warmers

- Durable stainless steel construction with hinged lid and extra large ladle slot
- Adjustable heat controls maintain safe serving temperatures for soups, stews, and sauces
- Double wall insulation keeps exterior cool-to-the touch
- Includes an anti-scald knob for safe operator handling
- Built with an anti-skid base for stability in busy service areas
- 10 quart capacity
- 110V
- 1-year limited parts and labor warranty

SE-ESW10 Black
SE-ESW10S Chrome



SE-ESW10

SE-ESW10S



Strip Warmers

- Provides consistent, efficient heating for buffet lines and pass-through stations
- Features a heavy-duty stainless steel housing
- Utilizes a durable sheathed element and a simple toggle switch
- Includes under-mount brackets and chains
- Designed for high-demand cafeterias, restaurants, and banquet halls
- 120V
- 6½" d x 2½" h

SE-SH24 24" wide
SE-SH36 36" wide
SE-SH48 48" wide
SE-SH60 60" wide
SE-SH72 72" wide

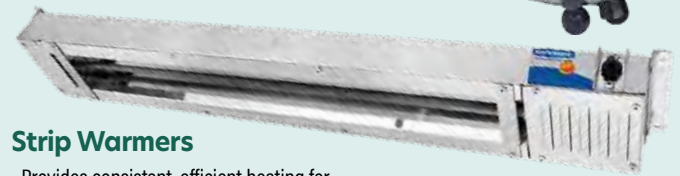

SE-SH48

Hot Hold® Dry/Moist Food Warmers

- Optimize your order-fulfillment speed
- Easier plate-prep assembly
- Hold moist cooked foods without drying it out
- Patented ThermalBreeze™ Technology achieves high energy efficiency
- Each Hot Hold® Warmer can warm up to four different foods at once, with the ability to split 50/50 between moist/dry foods or keep all at the same humidity level
- Comes with pre-programmed settings for many menu items
- Food timers visually and audibly indicate remaining window of time for optimal food quality
- Holds 1/3 size high-heat pans
- 19 1/2" w x 13 1/2" d
- 120V

nemco® | FOOD EQUIPMENT



Warm up to 4 different foods at once

6070-TT SHOWN STACKED.
PANS SOLD SEPARATELY

STANDARD	HEIGHT	CAPACITY
6070-TT	11 1/8"	(4) 2 1/2" d
6070-TF	12 5/8"	(2) 2 1/2" d & (2) 4" d
PASS-THRU		
6070P-TT	11 1/8"	(4) 2 1/2" d
6070P-TF	12 5/8"	(2) 2 1/2" d & (2) 4" d

From prep to plate with ease.



Mirage® Drop-In Induction Rethermalizers & Warmers

- Induction heating means no water required, faster retherm times and better temperature control
- Digital controls set temperature in °F and °C, or use presets for Soup, Crème Soup, Chili, and Mac & Cheese
- New lid design has permanently welded handle that doubles as a kickstand for the lid and the notched slot holds serving utensil in place, preventing it from sliding into the food
- Requires use of Vollrath induction-ready inset—failure to use insets may damage the unit and will void the warranty
- Includes programmed retherm mode
- 120V

RETHEMALIZERS	WARMERS
74401D 4 qt	74401DW 4 qt
74701D 7 qt	74701DW 7 qt
741101D 11 qt	741101DW 11 qt



Chip Warmer

- Top load style ensures first-in, first-out product rotation
- Sloping front allows secure closure and easy opening; door opens creating a shelf for scooping chips
- Fan circulates air for quick and even heating of chips
- Durable stainless steel construction with high density insulation
- Adjustable legs
- Lifetime warranty on heating elements



VCW26 26 Gallon,
26 1/2" w x 30 1/2" d x 30 1/2" h



Food Warming Drawer

- Heavy-duty 20 gauge polished stainless steel cabinet
- (1) 12" x 20" x 6" deep stainless steel pan, one recessed thermostat adjustable to 190°F and one humidity control
- Cabinet sides and top filled with 1" thick insulation
- (1) 475 watt heating element per drawer
- 4" adjustable legs
- Lifetime warranty on heating elements and drawer rollers

VVIS 1 Drawer,
27 1/2" w x 23 1/2" d x 16 1/4" h w/ Legs





Spiral Mixer

- Mixes pizza, bagels and artisan breads
- Two-speed motor provides superior dough oxygenation
- 8 speed available upon request, a first for this market in spiral mixers and allows for more precision in yeast dough production
- Standard in 2 speed
- Unique high-center bowl
- Integrated bowl drain
- Powerful motor handles tough doughs
- 208V



AEF035SP 77 qt Capacity



Planetary Mixer

- Stainless steel bowl, safety guard, dough hook, whip and flat beater
- 99 minute timer
- 7 programmable speeds and time settings
- 20 speed digital control
- No need to stop mixer to change speed
- Emergency stop
- Lever bowl lift with automatic lock-in-place feature
- 10 qt reduction kit for small production capacity
- Floor design
- Ergonomically designed for the operator
- Additional models available with capacities ranging from 10 to 140 qt
- 1-year labor and 2-year parts warranty



BTL020 20 qt Capacity



Removable polycarbonate safety guard

Planetary Mixer

- 8 quart/7 liter capacity
- Stainless steel bowl with handle
- 11 speeds
- 30 minute timer with 30 second increments
- Belt driven
- Includes dough hook, beater & whip attachments
- Electronic touch screen with light



PM001.1LT7



Planetary Mixers

- Gear-driven
- Includes stainless steel whip, hook and beater
- Safety switch on guard and bowl
- Not suitable for pizza, pita or bread dough*
- Other attachments and accessories available
- 1-year parts & labor warranty



	CAPACITY	HP
M10ETL*	10.5 qt	3/4
M20B*	20 qt	1 1/2
M30AETL*	30 qt	2
M40A220ETL	40 qt	2
M60A220ETL	60 qt	3 1/2



Planetary Mixers

- Gear-driven, high torque transmission
- Custom built motor
- Front mounted controls
- Heat-treated hardened steel alloy gears and shafts
- Includes stainless steel bowl, flat beater, wire whip and dough hook (SP60 includes bowl truck)
- 2-year parts & labor warranty



COUNTERTOP	CAPACITY	SPEEDS	MOTOR
SP05	5 qt	10	800 watts
BENCH			
SP20	20 qt	3	1/2 hp
SP25	25 qt	3	3/4 hp
FLOOR			
SP30	30 qt	3	1 hp
SP40	40 qt	3	2 hp
SP60	60 qt	3	3 hp



SP05

FOOD PREP

Stainless steel bowl, safety guard and bowl interlock mechanism



Spectrum™ 20L Planetary Mixer

- High-capacity stainless steel mixing bowl is ideal for bakeries, delis and cafés
- Heavy-duty die-cast iron construction for maximum durability
- 1.5 hp gear-driven, high torque 3-speed motor
- Includes a #12 attachment hub and three attachments - a wire whip, a flat beater and a spiral dough hook
- 1100W, 110V
- 19 7/8" x 21 3/4" x 29 3/4"
- 1-year parts and labor warranty
- Additional sizes available

EMP-20 21.1 qt



eurodib

LM Series Spiral Mixers

- Engineered to mix a wide variety of doughs in commercial bakeries and pizzerias
- Delivers a consistent mixing speed of 185 rpm for the hook and 15 rpm for the bowl
- Features a fixed bowl and spiral hook for powerful, consistent kneading
- Includes a built-in timer to program and set precise mixing times
- Built with an integrated emergency stop and bowl guard switch for operator safety
- 1-year parts and labor warranty, 3-month warranty on timer

	CAPACITY	VOLTAGE
LM20TETL	20 qt	110V
LM30TETL	30 qt	220V
LM40TETL	40 qt	220V
LM50TETL	50 qt	220V



Planetary Floor Mixer

- Variable speed transmission with overload protection
- Includes a stainless steel bowl, ingredient chute, batter beater, wire whip, dough hook and bowl scraper
- 2-year parts and labor warranty

SRM80+ 80 qt, 3 hp



Silverline Spiral Mixer w/Lifter

- Overturnable spiral mixer with an integrated lifter for automated discharge
- Features separate bowl and agitator motors for powerful, consistent mixing
- Stainless steel bowl, spiral dough hook and shaft
- 2 speeds and a reverse function with separate timers for precise mix control
- Powerful belt-driven motor for quiet operation
- Safety switch stops operation when the bowl lid is open
- 208/60/3
- 1-year on-site parts and labor warranty

SL120LB 265 lb



Pro Series Slicers

- Top mounted switches reduce failures
- Belt-driven motor
- Built-in dual stone sharpener
- Forged, hardened blades
- Removable carriage for easy cleaning
- Removable stainless steel slice deflector
- Sealed housing prevents moisture damage
- Dual ergonomic handles for easy slicing and Tritan™ clear hand guard
- Safety overload switch on bottom
- 1-year parts and labor warranty

Anodized cast aluminum and stainless construction

		SIZE	HP
EDV9C	Light Duty	9" Blade	1/4
EDV10C	Medium Duty	10" Blade	1/4
EDV12C	Medium Duty	12" Blade	1/3
EDV12	Heavy Duty	12" Blade	1/2
EDV13	Continuous Duty	13" Blade	1/2





Compact footprint for space-conscious kitchens



Redesigned S-Series Premium Heavy-Duty Slicers

- Anodized aluminum construction
- 13" steel blade
- Powerful 1/2 hp motor for all-day meat and cheese slicing
- Enhanced cleanability and ergonomic features
- Space-saving design
- 2-year parts and labor warranty

STANDARD

S213 Manual
S213A Automatic

ADVANCED

SG213 Manual
SG213A Automatic



Slicing made easy.



Accommodates products up to 10 1/2" long

G Series Medium-Duty Slicers & Accessories

- Hard chromed, special alloy hollow ground knife
- Anodized aluminum construction
- Permanently attached knife ring guard
- Slices tissue thin to 3/16" thickness
- Extended rod, end weight and chute
- Full gravity feed food chute
- All metal knife sharpener
- 115V
- 2-year parts and labor warranty

	BLADE	HP
G10	10"	1/3
G12	12"	1/2
G14	14"	1/2



TIP

Keep It Sharp for Cleaner Slices

A commercial slicer blade should typically be sharpened every day or after several hours of heavy use to maintain clean, consistent cuts. Dull blades can tear products, reduce efficiency and place extra strain on the motor. Regular sharpening also helps improve safety and extend the life of the slicer.

Take the following safety precautions:

- Consult the manufacturer's instructions regarding blade sharpening for your particular slicer
- Turn the power off and unplug your slicer before beginning the sharpening process
- Wear cut-resistant gloves when cleaning or sharpening the blade





Trinity Pro Combined Vegetable Slicer/Cutter Mixer

- Combines vegetable slicing and cutter mixer functions in a single unit
- Delivers reliable power with a 1 hp, 1800 rpm asynchronous industrial motor
- Features a watertight IPX5 control panel with a pulse function
- Equipped with half moon hopper and 2 small round feed chutes and design patented lever hopper for best ergonomics and quality of cut
- Fits up to 7 $\frac{3}{4}$ " high standard kitchen containers
- Magnetic safety system with motor brake prevents operation when the hopper is open
- Optional discs available of various sizes for slicing, grating, dicing and shredding
- All food-contact parts are BPA-free, removable without tools, and dishwasher safe
- Space-saving compact design, easy to move or store away - 13 $\frac{1}{8}$ "w x 12 $\frac{5}{8}$ "d x 20 $\frac{3}{4}$ "h
- 115V

602156 2.7 qt, 1 Speed

Designed for continuous feed operation



Slice. Dice. Deliver.



TRS Vegetable Slicer

- Offers wide range of dishwasher safe stainless steel discs for slicing, grating, shredding and dicing
- High discharge zone accommodates containers up to 8" high
- Continuous feed design
- Equipped with a large round feed hopper and a lever-integrated long vegetable hopper
- Designed with a 20° inclined base for easy loading and unloading
- Magnetic safety system with motor brake prevents operation when the hopper is open
- Features a tool-free removable, dishwasher safe hopper, lever and cutting chamber
- 9 $\frac{3}{4}$ "w x 19 $\frac{1}{4}$ "d x 20 $\frac{1}{4}$ "h
- 1 hp motor, 400 rpm
- 100-120V



600476 Processes 100-800 Meals per Service



CL Series Dynacube Manual Dicer

- Patented stainless steel cutting grid system assures a clean, safe and efficient dice
- Dices vegetables, fruit and cooked meat
- 6 interchangeable grid sets available, includes 1 grid set and corresponding pusher includes your choice of 1 grid set
- Collapsible legs for easy storage
- 1-year limited parts warranty



Veg Prep Machines

- Equipped with a magnetic safety system, motor brake and lever-activated auto restart
- Continuous feed lead and lateral ejection with two hoppers for maximum productivity
- Durable stainless steel construction built for years of dependable performance
- CL50E & CL50Gourmet are designed for 5 to 300 meals per service; up to 600 with the CL52E
- Large selection of 52 discs available
- 1-year parts and labor warranty



	CAPACITY PER HOUR	HP
CL50E	220 lb	1 $\frac{1}{2}$
CL50GOURMET	220 lb	1 $\frac{1}{2}$
CL52E	550 lb	2





VariCut & VariCut Deluxe Food Processors

- Produces precise julienne, dice, grate and slice cuts in high-volume kitchens
- Powerful ¾ hp motor processes up to 500 lb of product per hour
- VariCut features a 7-in-1 adjustable blade and over 30 blade options
- VariCut Deluxe features a counter-rotating chute for unique slicing and precision dicing
- Integrated safety interlocks and an automatic blade brake enhance operator protection

VC500 VariCut, 20" w x 16" d x 30" h
VCD500 VariCut Deluxe, 27" w x 23" d x 27" h



VC500

Stainless steel and aluminum construction



VCD500



Precision in every cut.



French Fry Cutter

- Saves time and increases yield with uniform cut fries
- Cuts up to 50 lb of potatoes per minute
- Stainless steel construction withstands heavy kitchen use
- 3 easy interchangeable sizes available
- Removable feed hopper, drum and blade cartridge for easy cleaning
- ½ hp motor provides continuous cutting power
- Produces consistent size fries

FFC50 26¼" w x 15¼" d x 27½" h



Combination Food Processors

- Multi-functional combination food processors with a cutter mixer bowl and veg prep capabilities
- Cutter mixer bowl designed for mixing, chopping, pureeing and blending (plus dicing with the R2Dice model)
- Veg prep attachment includes a stainless steel "S" blade, a gray composite bowl with handle and clear lid
- Attachments easily removed for cleaning
- Prepares up to 850 servings in 3 hours or less
- Backed by a 1-year Easy Replacement Warranty



R2N

	CAPACITY	HP
R2N	3 qt Bowl	1
R2DICE	3 qt Bowl	2
R301	3.5 qt Bowl	1½



Blixer® Commercial Food Processor

- Trusted by healthcare dining to puree both raw and cooked foods for (2 to 15) 7 oz portions to achieve IDDSI standards
- Fine-serrated blade and unique Blixer® arm create smooth consistencies
- Brushed stainless steel bowl with soft-touch handle
- 120V / 1½ hp motor handles large quantities with ease
- Gray body with stainless steel bowl complements any kitchen
- Backed by a 1-year Easy Replacement Warranty

BLIXER4 4.5 qt Capacity



IP65 control panel with a digital 15-minute timer



robot coupe

Vertical Cutter Mixer

- Designed for large volume food processing
- 2-speed, 7 hp motor (1800 and 3600 RPM) with pulse function
- 3 adjustable stainless steel "S" blades included
- Removable, 31 qt stainless steel bowl with tilting feature
- 23 $\frac{3}{8}$ "w x 27 $\frac{3}{8}$ "d x 48 $\frac{1}{8}$ "h
- 208/240V/3

R30T 31 qt



robot coupe



Vegetable Preparation Workstation

- Complete all-in-one workstation for high-volume vegetable preparation
- Includes 16 discs and 8 kits that process a wide variety of cuts including slicing, grating, julienne and dicing
- Includes 3 interchangeable stainless steel feed heads for maximum versatility
- Features a powerful 3 hp motor with a magnetic safety system and motor brake
- Comes with an ergonomic mobile trolley that accommodates 3 full size pans
- 60" w x 44" d x 72" h
- 208-240V

CL60WS Produces 1320 lb per hour



Immersion Blenders Power Mixers

- High-powered motors for efficient food processing
- Designed for heavy use in commercial kitchens
- Ideal for blending soups, sauces and purées
- Removable blades
- Direct-drive design for power and reliability
- All stainless steel motor cover and attachments
- 1-year parts and labor warranty



	LENGTH	HP
MP350	14" Shaft	1
MP450	18" Shaft	1.1
MP550	21" Shaft	1.2
MP600	24" Shaft	1.5
MP800	29" Shaft	1.6
TURBO		
MP350VV	14" Shaft	1
MP450VV	18" Shaft	1.1
W/ WHISK		
MP350COMBI	14" Shaft	1
MP450COMBI	18" Shaft	1.1
MP450FW	10" Whisk	1.1
MP450XLFW	27" Whisk	1.1

robot coupe

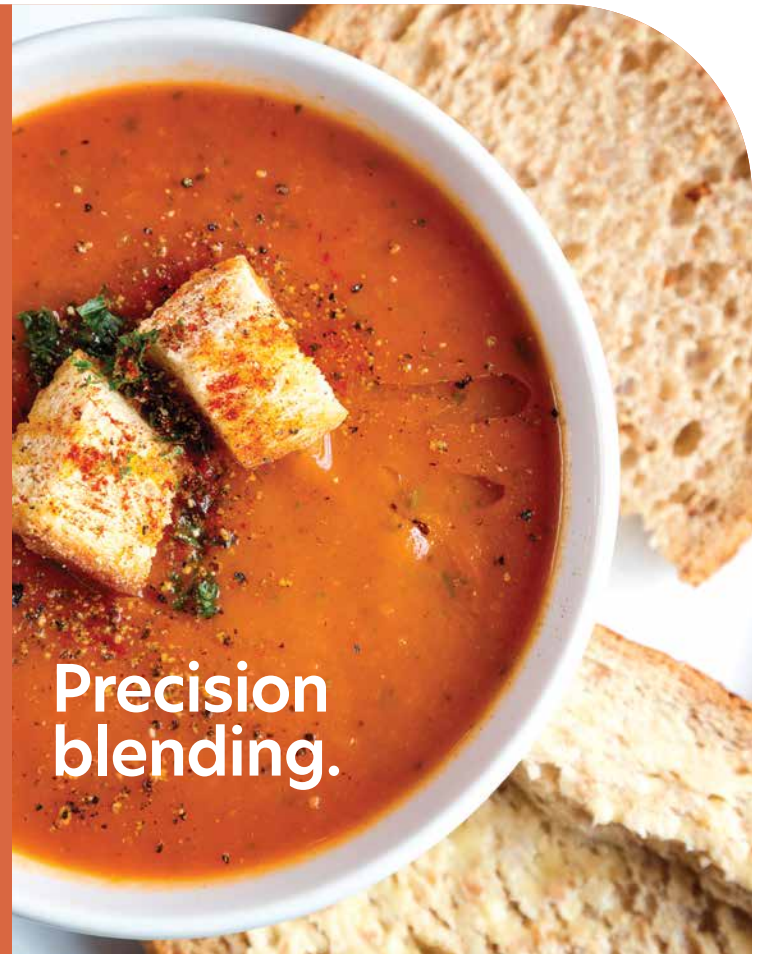

Precision blending.



Hamilton Beach
COMMERCIAL



Heavy-Duty Immersion Blenders

- Stainless steel shaft
- Titanium plated cutter blade
- Safety switch
- Continuous run switch
- Efficient motor design
- Advanced cooling fan
- 115V
- 1-year parts & labor warranty



	MODEL	CAPACITY	SHAFT	WATTS
MX005.1	MX91	15 gal	16"	460
MX042.1ES	SMX350ES	20 gal	14"	600
MX044.1ES	SMX550ES	40 gal	18"	600

Big Rig™ Immersion Blenders

- High-powered motor easily blends, chops, purees and emulsifies various ingredients
- Variable speed thumb dial with color-coded indicator light
- Ergonomic handle and shaft grip
- Detachable stainless steel blending shaft (attachments sold separately)
- Serviceable, high-visibility power cord
- Available in all sizes: 12", 14", 16" 18" & 21"
- 2-year ExpressCare Replacement warranty



HM1009 Compact, 9" Shaft
HM1014 Standard, 14" Shaft

Food Processor/Veggie Prep Combi

- Combination vegetable prep and food processor
- Stainless steel construction including 8.5 qt bowl
- Processes 200 to 1000 lb per hour
- Powerful 3 hp motor
- Waterproof LED control panel
- Force Control System maintains consistent force through different speeds
- 3 hp, 120V



CK-38V 8.5 qt



Immersion Blender

- Powerful 1½ hp motor provides high-speed, in-pot blending
- Ergonomic handle
- Removable, stainless steel blending shaft



XM-52 127 qt, 20% Shaft



Cutter-Mixer & Emulsifier

- Cuts, grinds, mixes, kneads and emulsifies food products in seconds
- Features a high-efficiency brushless motor that maintains torque across the entire speed range
- Force Control System maintains consistent force through different speeds
- Stainless steel construction including 8.5 qt bowl
- Offers an intuitive, waterproof LED control panel with continuous, timed and pulse modes
- Includes a reverse function for gentle mixing instead of cutting
- Designed with a transparent lid and an integrated scraper for consistent processing of liquids
- 3 hp, 120V



KE-8V 8.5 qt





Ergonomic dual-trigger grip and pivoting second handle



WSB500X

Heavy-Duty Big Stik® Evolution X Immersion Blenders

- High-performance motor powers through demanding, high-volume tasks
- Continuous ON for hands-free operation
- Variable speed control
- Removable stainless steel components
- 2-year limited warranty

	LENGTH	CAPACITY
WSB500X	12" Shaft	10 gal
WSB550X	14" Shaft	15 gal
WSB600X	16" Shaft	25 gal
WSB650X	18" Shaft	35 gal
WSB700X	21" Shaft	25 gal
WSBPPWX	10" Whisk	10 gal



10" spout clearance fits blenders and pitchers



Juice Extractor

- High-volume juice output for busy bars and cafes
- Automatic feed hopper quickly juices various fruits and vegetables
- Powerful, quiet 1 3/4 hp motor for continuous use
- Stainless steel and ABS plastic construction
- Continuous waste ejection hopper
- 8 qt pulp container
- 120V
- 1-year parts and labor warranty



J100 11 1/4" w x 28" d x 21" h





JuicePro Juicers

- Engineered for continuous, high-volume juicing
- Powerful motor extracts maximum yield from oranges
- Automatic pulp and peel ejection
- Durable stainless steel components
- Removable drip tray, pulp tray and peel bin for easy cleaning
- 115V



- JP001.1** 12 Oranges per Minute
- JP002.1** 24 Oranges per Minute



Durable polymer construction



E008.1

Electric Salad Spinners

- Removes excess water
- Engineered to increase yield and extend the shelf life of fresh produce
- 200W and 500 RPM
- 115V



- E008.1** EM25, 2.5 gal, 4 Heads of Lettuce
- E006.1.B.T** EM98, 5 gal, 8 Heads of Lettuce, Sealed Cover, Includes Stabilizing Base & 1 Minute Timer

BlendPro High Performance Commercial Blenders

- Combines 3 hp motor power with 10-speed digital controls
- Six-wing stainless steel blade assembly
- Impact-resistant 68 oz Tritan container
- Reaches speeds up to 38,000 rpm
- 115V



- BL003.1** Without Shield
- BL003.1SE** With Shield

10-speed digital controls



E007

Manual Salad Spinners

- Gears are made of the most durable plastic formula available
- Easy gear replacement
- 1-year warranty (includes gears)

- DRIES UP TO 2 HEADS OF LETTUCE**
- E007** SDMINISC, 1.25 gal/5 Liter Capacity, with Sealed Gears for Improved Sanitation
- DRIES UP TO 4 HEADS OF LETTUCE**
- E001** SD99, 2.5 gal/10 liter Capacity
- DRIES UP TO 8 HEADS OF LETTUCE**
- E002** SD92, 5 gal/20 liter Capacity

VP4 "Greens Machine" Vegetable Dryer

- Dries up to 16 heads of lettuce or 9 kg of greens in less than 5 minutes
- Features a stainless steel external drum for durability and easy cleaning
- Rotates at 400 RPM for efficient water removal from vegetables
- Includes a watertight digital control panel with a built-in timer
- Electrical braking system stops basket rotation for operator safety
- Compact design fits under standard counters
- Special basket shape for better and faster drying
- Truly mobile thanks to a built-in water reservoir (see data sheet for capacity) and option to alternatively drain directly to the floor
- Convenient power cord holder on back
- 29 1/2" w x 29 1/2" d x 32" h
- 120V
- 2-year parts and 1-year labor warranty

- 602258** 20 gal



Fresh greens everytime.

One Station Solution

John Boos delivers functional efficiency for every kitchen with commercial-grade stainless steel equipment built to handle the demands of daily service. This complete workstation combines a durable prep table, integrated hand sink and double overshelf to keep workflow organized and productivity high. Expertly crafted for lasting performance, each piece reflects John Boos' pride in craftsmanship, precision fabrication and commitment to quality every step of the way.

Double Overshelf

Maximize vertical space with added overhead storage for supplies and essentials.

Work Table

Heavy-duty stainless steel work surface with sink cutout for a seamless all-in-one workstation.

Drop-In Hand Sink

Convenient drop-in hand sink keeps sanitation close at hand during service.



Pass-Thru Shelf & Worktable

PTS16K-1860 | ST6-2460SSK-X

Support efficient kitchen flow with two components designed for durability and performance. The 60" w x 18" d pass-thru shelf, constructed from stainless steel with Stallion Safety Edge, mounts to the wall for smooth transfer between areas. Paired with a 60" w x 24" d work table featuring a sound-deadened stainless steel top, adjustable undershelf and stable leg system, each piece functions independently to enhance prep and workflow in high-volume commercial environments.

SAPPHIRE



NSF

Equipment Stands w/Undershelf

- Provides a stable, reinforced platform for heavy kitchen equipment
- Features a 16 gauge type 430 stainless steel top for corrosion resistance
- Reinforced with sound-deadened hat channels for superior rigidity
- Designed with a 2" splash guard on sides and rear to contain spills
- Includes a fully adjustable undershelf for customized storage capacity
- Adjustable bullet feet ensure level placement on uneven surfaces
- Stands 60" w or less have a capacity of 800 lb top and 300 lb undershelf; Stands 72" w or more have a capacity of 1000 lb top and 450 lb undershelf
- Ask about other sizes available

S/S TOP, SHELF & LEGS	S/S TOP, GALVANIZED SHELF & LEGS	
SMES-2418S	SMES-2418G	18" w x 24" d x 24" h
SMES-2424S	SMES-2424G	24" w x 24" d x 24" h
SMES-2436S	SMES-2436G	36" w x 24" d x 24" h
SMES-2448S	SMES-2448G	48" w x 24" d x 24" h
SMES-2460S	SMES-2460G	60" w x 24" d x 24" h
SMES-2472S	SMES-2472G	72" w x 24" d x 24" h
SMES-3018S	SMES-3018G	18" w x 30" d x 24" h
SMES-3024S	SMES-3024G	24" w x 30" d x 24" h
SMES-3036S	SMES-3036G	36" w x 30" d x 24" h
SMES-3048S	SMES-3048G	48" w x 30" d x 24" h
SMES-3060S	SMES-3060G	60" w x 30" d x 24" h
SMES-3072S	SMES-3072G	72" w x 30" d x 24" h

SAPPHIRE

SMEMS-2424G



Mixer Stands with Undershelf

- Provides a heavy-duty, stable platform for mixers and other countertop equipment
- Features a 16 gauge, 430 stainless steel top for commercial kitchen use
- Designed with a 1½" marine edge on all sides to contain spills
- Reinforced with sound-deadening hat channels for increased strength
- Includes a fully adjustable undershelf for convenient storage
- Stands on 1½" tubular legs with adjustable bullet feet for leveling on uneven floors
- Constructed with hemmed edges for added rigidity and safe handling

STAINLESS STEEL	S/S WITH GALVANIZED LEGS	
SMEMS-2424S	SMEMS-2424G	24" w x 24" d x 20" h
SMEMS-3024S	SMEMS-3024G	24" w x 30" d x 20" h
SMEMS-3030S	SMEMS-3030G	30" w x 30" d x 20" h
SMEMS-3630S	SMEMS-3630G	36" w x 36" d x 20" h

NSF



CST-3048

NSF



CST-2460S

Stainless Steel Chef Tables

- Provides a stable work surface with an integrated open-front storage cabinet
- Features a heavy-duty 14 gauge stainless steel top and body
- 6" stainless steel legs with 1" of height adjustment for leveling on uneven floors
- Designed with a flat top and square edges for flush installation with other equipment
- 1-year warranty

W/CHEF BASE	DIMENSIONS	DOORS
CST-3048	48" w x 30" d x 34¾" h	-
CST-2460S	60" w x 24" d x 34¾" h	2
CSTR5-3096H	96" w x 30" d x 39¾" h	4

BK RESOURCES



Prep Table

- Streamlines workflow by combining a prep surface and integrated sink
- Constructed with a heavy-duty 18 gauge T-304 stainless steel top
- Marine edge countertop contains spills
- Integrated 6" backsplash protects walls from splashes and debris
- Features a 16" x 20" x 10" deep sink bowl on left side with an included basket drain
- Adjustable undershelf provides convenient and customizable storage space
- Adjustable bullet feet create a stable, level surface on uneven floors
- 1-year warranty

BKMPT-3060S-L-P-G 60" w x 30" d x 41¾" h

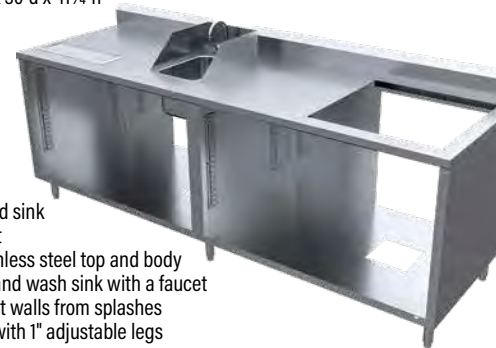

Soda Dispenser Cabinet

- Consolidates a work surface, hand sink and dispenser station in 1 cabinet
- Constructed with a 14 gauge stainless steel top and body
- Includes an integrated drop-in hand wash sink with a faucet
- Equipped with a 5" riser to protect walls from splashes
- Offers stability on uneven floors with 1" adjustable legs
- 1-year warranty

MOD-BTSD 96" w x 30" d x 39¾" h

BK RESOURCES

Stainless Steel Work Tables

STEELWORKS

- Provides a durable, all-stainless steel workspace for any commercial kitchen
- Features a stainless steel top and undershelf
- Stainless steel legs with 1" adjustable bullet feet level the table on uneven floors
- Reinforced with stainless steel hat channels to support heavy loads
- Designed with square edges for flush installation with other equipment
- Additional undershelves and open base models available
- Additional sizes available



SWWTS-1836-316

FLAT TOP		W/ 2" SPLASH GUARD	
SWWTS-3012-318	12" w x 30" d x 34" h	SWWTS-3012-2R-318	12" w x 30" d x 34" h
SWWTS-1836-316	36" w x 18" d x 34" h	SWWTS-1836-2R-316	36" w x 18" d x 34" h
SWWTS-2472-318	72" w x 24" d x 34" h	SWWTS-2472-2R-318	72" w x 24" d x 34" h



SWWTS-1836-2R-316



Wall Cabinets

- Provides heavy-duty wall-mounted storage for commercial kitchen supplies and equipment
- Constructed from 18 gauge, type 430 stainless steel for durability
- Features all TIG-welded seams polished to a satin finish
- Designed with a sloped top to enhance sanitation and simplify cleaning
- Includes 1 fixed intermediate shelf to optimize internal storage space
- 15"d x 32½"h

SLIDING DOORS	DOORS	WIDTH	HINGED DOORS	DOORS	WIDTH	OPEN FRONT	DOORS	WIDTH
WCS-15-36	2	36"	WCH-15-36	2	36"	WCO-15-36	—	36"
WCS-15-48	2	48"	WCH-15-48	2	48"	WCO-15-48	—	48"
WCS-15-60	2	60"	WCH-15-60	2	60"	WCO-15-60	—	60"
WCS-15-72	2	72"	WCH-15-72	4	72"	WCO-15-72	—	72"
WCS-15-96	4	96"	WCH-15-96	4	96"	WCO-15-96	—	96"



Swing-out handle provides safe push or pull

Heavy-Duty Push-Pull Utility Cart

- Transport up to 3x more and make fewer trips
- Optional on-board stowable drawbar system allows you to tow multiple carts at one time
- Innovative handle design offers the flexibility to push or pull
- Hinged handle locks securely in upright position for traditional pushing action
- Durable stainless steel construction
- Carts have a 700 lb capacity and feature (3) 21" x 33" shelves
- Made in USA

163421 Utility Car, 22"w x 38"l x 41¼"h
169168 S/S Stowable Drawbar, 14½"l
170867 Trailing Cart, 22¾"w x 38¾"l x 37"h



Electric Utility Cart



- Stainless steel construction for easy sanitation
- 700 lb capacity across three 33"l x 21"w shelves
- Powered by dual hot-swappable batteries for continuous use
- Maneuvers easily with forward/reverse controls and 6" wheels
- Emergency stop feature increases operator safety

173670 21½"w x 40¾"l x 40¼"h



All welded construction.

Standard Heavy-Duty Aluminum Pan Rack

- Perfect for storing/transporting baked goods
- All welded construction with a front load design
- Holds full size 18" x 26" pans or half size 18" x 13" pans (two per shelf)
- 5" casters
- 20½" w x 26" d x 70¼" h
- Made in USA
- Custom sizes available
- Lifetime guarantee against rust



401A Holds 20 Full Pans



Mobile Can Storage Rack

- Inclined angle and T-Bar guides provide easy access for can selection, rotation and inventory
- Shipped set up and ready to use
- 5" swivel casters
- 25½" w x 35" d x 82¼" h
- Made in USA
- Custom sizes available
- Lifetime guarantee against rust

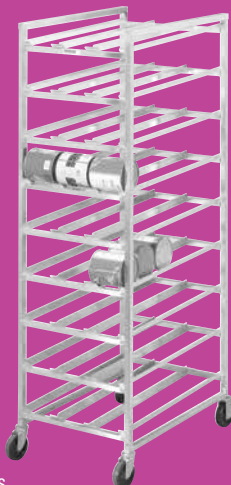

CSR-9M Holds 162 #10 Cans or 216 #5 Cans



Sheet Pan Racks

- Provides mobile, high-density storage and transport for sheet pans
- SMAPR-9PTKD and SMAPR-9TW feature a ½" thick, BPA-free white polyethylene prep top
- Heavy-duty 16-gauge aluminum construction resists corrosion
- Maneuvers smoothly on 5" swivel casters with 2 locking brakes
- Features 3" of spacing between runners



HALF-SIZE, W/POLY TOP - 20¼"W X 26¼"D X 36"H
SMAPR-9PTKD† Holds 9 Full Size Sheet Pans, 300 lb
SMAPR-9TW* Holds 9 Full Size Sheet Pans, 350 lb

HALF-SIZE, 20¼"W X 26"D X 39¼"H
SMAPR-10KD† Holds 10 Full Size Sheet Pans, 350 lb
SMAPR-10W* Holds 10 Full Size Sheet Pans, 400 lb

FULL-SIZE, 20¼"W X 26"D X 69"H
SMAPR-20KD† Holds 20 Full Size Sheet Pans, 700 lb
SMAPR-20W* Holds 20 Full Size Sheet Pans, 800 lb
 † Knock-down
 * Welded



Heavy-Duty Dunnage Racks

- Elevates bulk ingredients and supplies safely off the floor
- Fully welded from heavy-duty ½" square aluminum tubing
- Supports a static weight load capacity up to 2000 lbs
- Rust-proof and corrosion-resistant for use in dry or cold storage
- Features plastic feet inserts to protect floors from damage



SMADR-14248	24" w x 14" d x 8" h	SMADR-202412	24" w x 20" d x 12" h
SMADR-14368	36" w x 14" d x 8" h	SMADR-203612	36" w x 20" d x 12" h
SMADR-14488	48" w x 14" d x 8" h	SMADR-204812	48" w x 20" d x 12" h
SMADR-182412	24" w x 18" d x 12" h	SMADR-206012	60" w x 20" d x 12" h
SMADR-20248	24" w x 20" d x 8" h	SMADR-242412	24" w x 24" d x 12" h
SMADR-20368	36" w x 20" d x 8" h	SMADR-243612	36" w x 24" d x 12" h
SMADR-20488	48" w x 20" d x 8" h	SMADR-244812	48" w x 24" d x 12" h
SMADR-20608	60" w x 20" d x 8" h	SMADR-246012	60" w x 24" d x 12" h

STORAGE & TRANSPORT

CAMBRO
TRUSTED DURABILITY

Camshelving® Elements® XTRA Starter Units

- Withstands storage temperatures from -36° to 190°F
- Unit holds 2400 lb, evenly distributed, 800 lb per shelf
- Post connector locks in place onto the wraparound collar wedge for enhanced stability
- Universal traverses can be installed every 4" with single snap on dovetail
- Includes 2 factory assembled stationary post kits, 8 or 10 traverses, traverse dovetails and shelf plates
- Lifetime warranty against rust and corrosion
- Speckled Gray

Available with vented, solid or vented and 1 solid shelf



Stay organized with ease.

VENTED	DIMENSIONS	SHELVES	EXU245484V5480	54"l x 24"w x 84"h	5
EXU183672V4480	36"l x 18"w x 72"h	4	EXU186072V4480	60"l x 18"w x 72"h	4
EXU243672V4480	36"l x 24"w x 72"h	4	EXU216072V4480	60"l x 21"w x 72"h	4
EXU243684V5480	36"l x 24"w x 84"h	5	EXU246072V4480	60"l x 24"w x 72"h	4
EXU184272V4480	42"l x 18"w x 72"h	4	EXU246072V5480	60"l x 24"w x 72"h	5
EXU214272V4480	42"l x 21"w x 72"h	4	EXU246084V5480	60"l x 24"w x 84"h	5
EXU244272V4480	42"l x 24"w x 72"h	4	EXU247272V4480	72"l x 24"w x 72"h	4
EXU184872V4480	48"l x 18"w x 72"h	4			
EXU214872V5480	48"l x 21"w x 72"h	5	SOLID	DIMENSIONS	SHELVES
EXU244872V4480	48"l x 24"w x 72"h	4	EXU244884S5480	48"l x 24"w x 84"h	5
EXU244884V4480	48"l x 24"w x 84"h	4			
EXU244884V5480	48"l x 24"w x 84"h	5	SOLID/VENTED		
EXU245472V4480	54"l x 24"w x 72"h	4	EXU244872VS4480	48"l x 24"w x 72"h	4

Elements® XTRA Series High Density Storage Top Rail Systems

- Increases storage capacity up to 40% in an existing footprint with a high-density design
- Top-mounted track system glides smoothly, even over uneven floor surfaces
- Completely rust-free construction is ideal for dry storage and walk-in freezers
- Mobile units feature low-friction casters
- 900 lb per Mobile unit and 2400 lb per Stationary unit
- Vented shelves
- 2 stationary units included
- Lifetime warranty against rust and corrosion
- Speckled Gray

CAMBRO
TRUSTED DURABILITY



	DIMENSIONS	SIZE
EXFST143PKG480	14"l x 24"w x 82"h	3 Mobile Shelving Units
EXFST164PKG480	16"l x 24"w x 82"h	4 Mobile Shelving Units
EXFST1855PKG480	18½"l x 24"w x 82"h	5 Mobile Shelving Units



EXFST143PKG480



Tubular shelving engineered to support substantial weight

Heavy-duty aluminum construction.



Vented shelf surfaces promote air circulation

TA2048-5-KIT

Cantilever Shelving Kit

- Cantilever design provides open, post-free access for bulk storage and inventory
- Heavy-duty aluminum construction offers exceptional strength and corrosion resistance
- Complete kit includes all uprights, shelves, cross supports and hardware for assembly
- Made in USA
- Custom sizes available
- Lifetime guarantee against rust

CSU-TT2048-4-KIT 47"l x 22½"w x 72"h

Adjustable Tubular Shelving Kits

- Modular tubular design creates highly configurable storage for walk-ins and pantries
- Heavy-duty aluminum construction provides exceptional strength and corrosion resistance
- Shelves adjust along posts to maximize vertical storage capacity
- Kit includes adjustable shelves, ASAU72 uprights (set of 4) and hardware for assembly
- 48"l x 20"w x 72"h
- Made in USA
- Custom sizes available
- Lifetime guarantee against rust

TA2048-4-KIT 4 Shelves
TA2048-5-KIT 5 Shelves



Camshelving® Elevation Series Wall Shelving

- Maximize wall space with vertical shelving designed for commercial kitchens
- Corrosion-resistant construction withstands wet and humid environments
- Durable design supports heavy loads for reliable storage
- Camshelving® Elevation Series adapts to various kitchen tasks and workflows
- Hygienic design promotes clean and organized workspaces
- Kits include: (1) 40" Aluminum Wall Track, (1) or (2) 30" Wall Uprights, (1) 18" x 36" Vented Shelf Kit, (1) 18" x 36" Hanging Pegboard and Pegboard Accessories
- Task Station does not come with Pegboard Accessories
- Black

STARTER KITS

EWS36SINK110 Sink
EWS36PREP110 Prep
EWS36TASK110 Task

STATION ADD-ON KITS

EWSA36SINK110 Fits Sink
EWSA36PREP110 Fits Prep
EWSA36TASK110 Fits Task



SmartWall® Life Wall Shelving Kits

- Organizes supplies above prep tables and sinks to maximize work surface area
- Type 304 stainless steel components
- Polymer shelves feature Microban antimicrobial protection
- Integrated grid system with included accessories
- Lifetime warranty against rust and corrosion
- Kits include wall track, uprights, shelf supports, MetroMax 4 shelves, wall grid and accessories



SINK SHELVING KITS	DIMENSIONS	SHELVES
SW-1836S4-30-SINK	40"l x 31¼"w	(1) 18" x 36"
SW-1848S4-30-SINK	56"l x 31¼"w	(1) 18" x 48"
SW-1872S4-30-SINK	80"l x 31¼"w	(2) 18" x 36"
SW-1872S4-45-SINK	80"l x 44¾"w	(4) 18" x 36"
PREP SHELVING KITS	DIMENSIONS	SHELVES
SW-1836S4-30-PREP	40"l x 31¼"w	(1) 18" x 36"
SW-1848S4-30-PREP	56"l x 31¼"w	(1) 18" x 48"
PIZZA PREP SHELVING KIT	DIMENSIONS	SHELVES
SW-1836S4-30-PIZZA	40"l x 31¼"w	(1) 18" x 36"





MetroMax 4® Polymer Shelving

- Lifetime warranty against rust and corrosion
- Lift-off open grid and solid polymer shelf mats are dishwasher safe
- Each unit features 4 shelves
- Many other sizes available
- Backed by a Never Collapse Guarantee

GRID MATS

- MAX4-1824G
- MAX4-1830G
- MAX4-1836G
- MAX4-1842G
- MAX4-1848G
- MAX4-1854G
- MAX4-1860G
- MAX4-2124G
- MAX4-2130G
- MAX4-2136G
- MAX4-2142G
- MAX4-2148G
- MAX4-2154G
- MAX4-2160G
- MAX4-2424G
- MAX4-2430G
- MAX4-2436G
- MAX4-2442G
- MAX4-2448G
- MAX4-2454G
- MAX4-2460G

SOLID MATS

- MAX4-1824F
- MAX4-1830F
- MAX4-1836F
- MAX4-1842F
- MAX4-1848F
- MAX4-1854F
- MAX4-1860F
- MAX4-2124F
- MAX4-2130F
- MAX4-2136F
- MAX4-2142F
- MAX4-2148F
- MAX4-2154F
- MAX4-2160F
- MAX4-2424F
- MAX4-2430F
- MAX4-2436F
- MAX4-2442F
- MAX4-2448F
- MAX4-2454F
- MAX4-2460F

DIMENSIONS

- 24"l x 18"w
- 30"l x 18"w
- 36"l x 18"w
- 42"l x 18"w
- 48"l x 18"w
- 54"l x 18"w
- 60"l x 18"w
- 24"l x 21"w
- 30"l x 21"w
- 36"l x 21"w
- 42"l x 21"w
- 48"l x 21"w
- 54"l x 21"w
- 60"l x 21"w
- 24"l x 24"w
- 30"l x 24"w
- 36"l x 24"w
- 42"l x 24"w
- 48"l x 24"w
- 54"l x 24"w
- 60"l x 24"w



POSTS

STATIONARY

- MX13P
- MX27P
- MX33P
- MX54P
- MX63P
-
- MX74P
- MX86P

STEM CASTERS

- 5PSTEX
- 5PSTEBX

MOBILE

- MX13UP
- MX27UP
- MX33UP
- MX54UP
- MX63UP
- MX70UP
- MX74UP
- MX86UP

DIMENSIONS

- 13"h
- 27"h
- 33"h
- 54"h
- 63"h
- 70"h
- 74"h
- 86"h

Microban® antimicrobial protection is built into the shelf mats, frames and posts



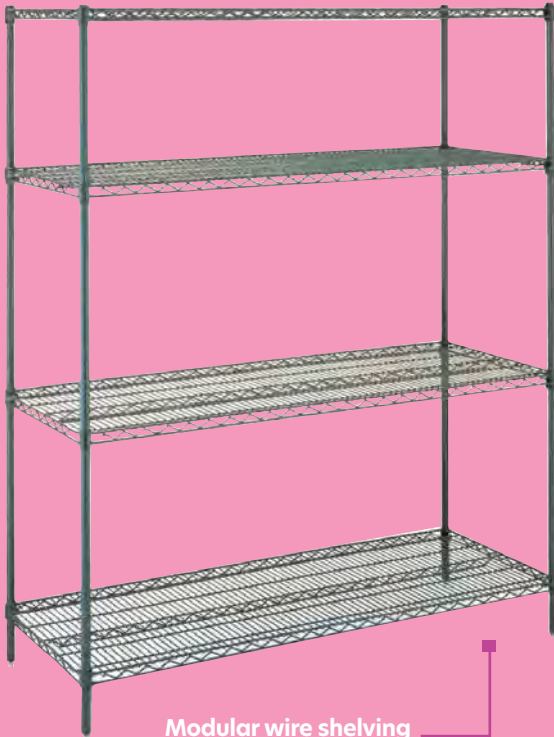

Modular wire shelving components for custom storage configurations



Epoxy Coated Wire Shelving

- Carbon steel construction with a proprietary Gray-Guard™ epoxy finish
- Open wire design promotes air circulation and minimizes dust accumulation
- Front-to-back wire orientation allows for smooth sliding of items
- Adjusts in 1" increments along grooved posts for customized shelf height
- Shelves up to 48" long can hold up to 800 lb per shelf, shelves longer than 48" can hold up to 600 lb per shelf (with weight evenly distributed)
- 10-year limited warranty on shelves and posts against rust and corrosion

SHELVES

J1824G	24"l x 18"w
J1830G	30"l x 18"w
J1836G	36"l x 18"w
J1842G	42"l x 18"w
J1848G	48"l x 18"w
J1854G	54"l x 18"w
J1860G	60"l x 18"w
J1872G	72"l x 18"w
J2424G	24"l x 24"w
J2430G	30"l x 24"w
J2436G	36"l x 24"w
J2442G	42"l x 24"w
J2448G	48"l x 24"w
J2454G	54"l x 24"w
J2460G	60"l x 24"w
J2472G	72"l x 24"w

STATIONARY POSTS

J54G	54%h
J63G	62%h
J74G	74%h
J86G	86%h

MOBILE POSTS

J54UG	53%h
J63UG	61%h
J74UG	73%h
J86UG	85%h

5" RUBBER CASTERS

J5	Stem Swivel
J5B	Stem Brake

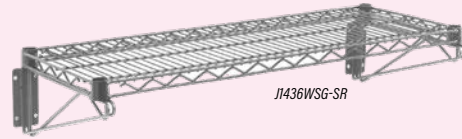

J1436WSG-SR

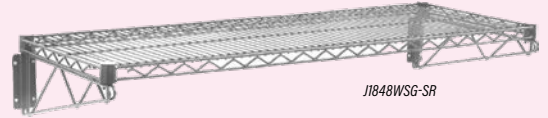

J1848WSG-SR

Wall Mount Shelving Kits

- Complete wall-mounted shelving kits to maximize vertical storage
- Features a protective Gray-Guard™ epoxy finish against rust and corrosion
- Open wire design promotes air circulation around stored products
- Includes 1 wire shelf and all necessary hardware for installation
- 1-year limited warranty, 10-year limited shelf warranty

J1436WSG-SR	36"l x 14"w x 7½"h
J1448WSG-SR	48"l x 14"w x 7½"h
J1836WSG-SR	36"l x 18"w x 7½"h
J1848WSG-SR	48"l x 18"w x 7½"h



Chromate finish provides rust and corrosion resistance

3-Shelf Utility Cart

- Heavy-duty mobile solution for commercial transport and storage
- 900 lb load capacity
- Assembles quickly without the need for tools
- Features (3) 36" x 18" open wire shelves and 2 handles
- 5" rubber casters
- 1-year warranty against defects in material and workmanship



J1836WC-3-SR	36"l x 18"w x 39"h
--------------	--------------------



Supports a heavy-duty load capacity of 300 lb per shelf



Wire Shelving Kits

- Complete 4-tier wire shelving solution in a convenient all-in-one kit
- Chrome finished wire design promotes air circulation and minimizes dust accumulation
- Shelves adjust on 1" increments for versatile storage configurations
- Includes posts, shelves and all installation hardware
- Also available in Green Epoxy and Black Epoxy finish
- 1-year limited warranty

RWR72-1830LD	30"l x 18"w x 72"h
RWR72-1836LD	36"l x 18"w x 72"h
RWR72-1842LD	42"l x 18"w x 72"h
RWR72-1848LD	48"l x 18"w x 72"h
RWR72-2430LD	30"l x 24"w x 72"h
RWR72-2436LD	36"l x 24"w x 72"h
RWR72-2442LD	42"l x 24"w x 72"h
RWR72-2448LD	48"l x 24"w x 72"h



Wire design promotes air circulation.



Polymer Shelving Kits

- Stationary 4-tier shelving kit with a hybrid wire and polymer mat construction
- Protected by a green epoxy antimicrobial coating for enhanced sanitation
- Louvered polymer mat design allows for air circulation around product
- Ships as a complete knockdown kit with 4 posts, 4 wire frames, 4 plastic mats and 4 packs of split sleeves
- 15-year limited warranty on epoxy, lifetime limited warranty on plastic



WR74-1830WPM	30"l x 18"w x 74"h	WR74-2142WPM	42"l x 21"w x 74"h
WR74-1836WPM	36"l x 18"w x 74"h	WR74-2148WPM	48"l x 21"w x 74"h
WR74-1842WPM	42"l x 18"w x 74"h	WR74-2430WPM	30"l x 24"w x 74"h
WR74-1848WPM	48"l x 18"w x 74"h	WR74-2436WPM	36"l x 24"w x 74"h
WR74-2130WPM	30"l x 21"w x 74"h	WR74-2442WPM	42"l x 24"w x 74"h
WR74-2136WPM	36"l x 21"w x 74"h	WR74-2448WPM	48"l x 24"w x 74"h



Supports up to 600 to 800 lb of weight per shelf



Heavy-gauge type 430 stainless steel cabinet



F1916-VSCS-DL

Mop Sink Cabinets

- Consolidates janitorial supplies and mopping tasks into a single, organized unit
- Durable type 304 stainless steel sink
- Features an 8" deep-drawn seamless mop sink with a 2" NPS drain
- Sink measures 16" x 20" x 8"
- Includes service faucet, spray hose and hose bracket for immediate use
- Multiple fixed interior shelves and an integrated mop hanger provide ample storage
- Hinged double doors with lockable handles for secure access
- Louvered sides and an open back design promote air circulation to aid drying

SINGLE
F1916-VSCS 25" w x 22 1/4" d x 84 1/4" h



DOUBLE
F1916-VSCS-DL Mop Sink at Left, 47 1/2" w x 22 1/4" d x 84 1/4" h
F1916-VSCS-DR Mop Sink at Right, 47 1/2" w x 22 1/4" d x 84 1/4" h



Anti-Splash Floor Troughs

- Features a patented anti-splash design to keep floors safe and dry
- Constructed from all-welded 14 gauge, type 304 stainless steel for corrosion resistance
- Built-in pitch directs all fluid toward the drain
- Includes a subway-style steel grate with 1" spacing and a removable perforated debris basket
- Accommodates a standard 4" diameter drain pipe



ASFT-1224-SG	24" l x 12" w	ASFT-2436-SG	36" l x 24" w
ASFT-1524-SG	24" l x 15" w	ASFT-2448-SG	48" l x 24" w
ASFT-1824-SG	24" l x 18" w		



Floor Troughs

- Manages excess water to maintain safe and sanitary floor conditions
- Features all-welded 14 gauge type 304 stainless steel for corrosion resistance
- Built-in pitch directs fluid toward the drain
- Subway-style stainless steel grates with 1" spacing provides high-volume drainage
- Includes a removable perforated basket to catch debris
- Accommodates a 4" diameter waste pipe



FT-1224-SG	24" l x 12" w	FT-2436-SG	36" l x 24" w
FT-1524-SG	24" l x 15" w	FT-2448-SG	48" l x 24" w
FT-1824-SG	24" l x 18" w		



Crusader Round Trash Cans

- High-density polyethylene construction
- Integrated UV inhibitor
- Dolly available for all round trash cans
- Available in gray, red, yellow, black or white unless noted
- Available in other capacities

TRASH CANS	CAPACITY	DIMENSIONS
CTC-10	10 Gal	15 1/2" dia x 17 3/8" h
CTC-32	32 Gal	22" dia x 27 3/8" h
CTC-55*	55 Gal	26 3/8" dia x 33" h

LIDS	FITS
CTC-L10	10 Gal
CTC-L32	32 Gal
CTC-L55*	55 Gal



Crusader Thin Trash Cans

- High-density polyethylene construction
- Engineered with a slim profile to fit confined spaces
- Integrated venting channels and bag cinches
- Optional dollies with non-marking casters
- Available in gray, black or brown unless noted

TRASH CANS	CAPACITY	DIMENSIONS
CTH-16	16 Gal	22" w x 25" h
CTH-23	23 Gal	22" w x 30" h

ADDITIONAL ITEMS (FITS CTH-16 & CTH-23)

CTH-LDS	Drop Shot Lid
CTH-MOB*	Mobile Kit
CTH-DLY*	Dolly

*ONLY AVAILABLE IN BLACK



ADDITIONAL ITEM

CTC-DLY** Dolly

*ONLY AVAILABLE IN GRAY OR BLACK, ** ONLY AVAILABLE IN BLACK



Crusader Thin Recycling Containers

- High-density polyethylene construction
- Space-saving thin profile
- Polished look for front-of-house placement
- Encourages efficient sorting to support waste management programs
- Available in blue or green

TRASH CAN	CAPACITY	DIMENSIONS
CTH-23R	23 Gal	22" w x 11" d x 30" h

LIDS (FITS CTH-23R)

CTH-LCB	Can/Bottle
CTH-LMX	Mixed Recycle
CTH-LPA	Paper
CTH-LFT	Flat Lid
CTH-LHFT	Flat Lid w/Handle

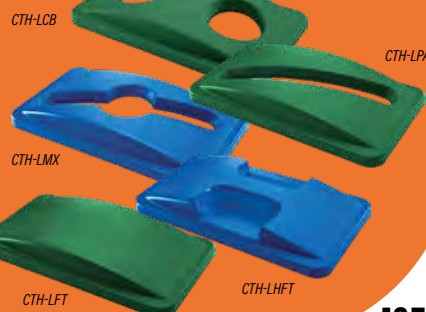

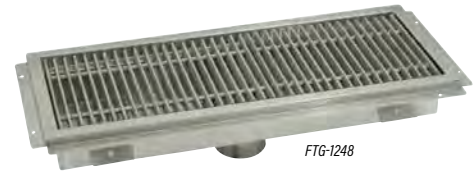

Stainless Steel Floor Drain Troughs

- Heavy-duty 14 gauge 304 stainless steel construction
- Pitched trough design with a creased bottom
- Removable subway grating with 3/8" spacing
- Includes a stainless steel strainer basket

S/S GRATE	FIBERGLASS GRATE	DIMENSIONS
FTG-1224	FFTG-1224	24"l x 12"w
FTG-1824	FFTG-1824	24"l x 18"w
FTG-2424	FFTG-2424	24"l x 24"w
FTG-1230	FFTG-1230	30"l x 12"w
FTG-1830	FFTG-1830	30"l x 18"w
FTG-2430	FFTG-2430	30"l x 24"w
FTG-1236	FFTG-1236	36"l x 12"w
FTG-1836	FFTG-1836	36"l x 18"w
FTG-2436	FFTG-2436	36"l x 24"w
FTG-1242	FFTG-1242	42"l x 12"w
FTG-1842	FFTG-1842	42"l x 18"w

S/S GRATE	FIBERGLASS GRATE	DIMENSIONS
FTG-2442	FFTG-2442	42"l x 24"w
FTG-1248	FFTG-1248	48"l x 12"w
FTG-1848	FFTG-1848	48"l x 18"w
FTG-2448	FFTG-2448	48"l x 24"w
FTG-1254	FFTG-1254	54"l x 12"w
FTG-1854	FFTG-1854	54"l x 18"w
FTG-2454	FFTG-2454	54"l x 24"w
FTG-1260	FFTG-1260	60"l x 12"w
FTG-1860	FFTG-1860	60"l x 18"w
FTG-2460	FFTG-2460	60"l x 24"w

Drainage that's built to last.



Knee/Foot Valve Operated Hand Sinks

- Hands-free knee and foot pedal operation
- Welded type 304 stainless steel construction
- Inverted "V" edge contains splashes to keep surrounding floor areas dry
- Splash-mounted gooseneck spout
- 13 1/2" x 9 3/4" x 6 3/4" deep bowl



KNEE PEDAL
HSA-10-FKP 18 1/2" w x 14 3/4" d x 17 1/2" h, Includes: Spout, Single Pedal Knee Valve, Skirt & Basket Drain

FOOT PEDAL
HSA-10-FA-1P 18 1/2" w x 14 3/4" d x 40" h, Includes: Spout, Single Foot Pedal, P-Trap, Tail Piece, & Basket Drain



Corner Mop Sinks

- Floor-mounted sinks designed for space-saving corner installation
- Heavy-gauge type 304 stainless steel bowl and skirt
- Fully welded and polished fabricated bowl provides a seamless interior
- Creased bowl base improves drainage and prevents water pooling

F2121-8-CDE



F2121-8-CNR

DROP FRONT EDGE
F2121-8-CDE 24" w x 24" d x 12" h, 8" Bowl
F2121-12-CDE 24" w x 24" d x 16" h, 12" Bowl

FLUSH FRONT EDGE
F2121-8-CNR 24" w x 24" d x 12" h, 8" Bowl
F2121-12-CNR 24" w x 24" d x 16" h, 12" Bowl



Electronic Eye Hand Sink

- Activates water flow via an electronic-eye sensor for hands-free operation
- Constructed of heavy gauge type 304 stainless steel
- Features a 12 3/4" bowl with a positive drain for complete water removal
- Designed with an inverted V-edge to contain splashes and spills
- Includes a high backsplash to protect walls from water
- 120V
- Comes with wall mounting brackets for secure installation
- Includes: spout, electronic eye, basket drain, left & right splash guard



HSA-10-FE-LRS 18 1/2" w x 14 3/4" d x 12 3/4" h



Multi-Station Wall Mounted Hand Sinks

- 16 gauge stainless steel construction
- Tubular stainless steel wall supports
- Gooseneck faucets included
- 8½" high backsplash
- 16" w x 8" d bowl size
- 19½" d x 28½" h

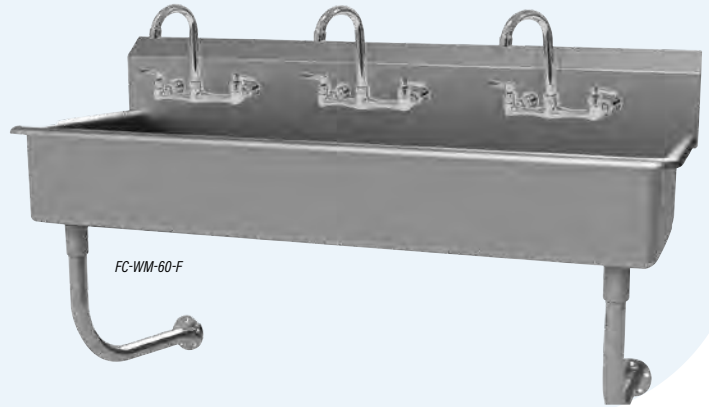
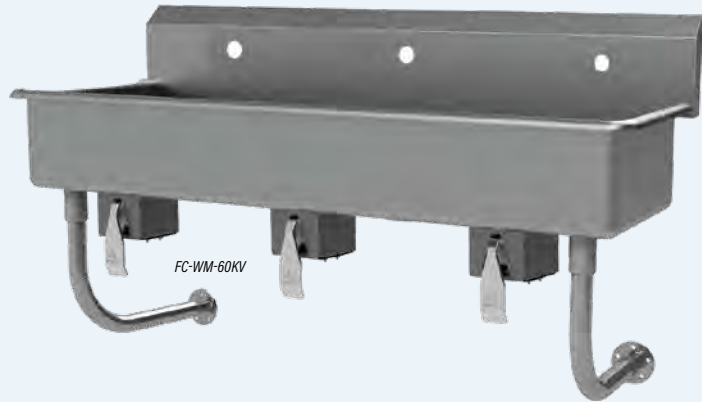

KNEE OPERATED

FC-WM-40KV	2 Stations, 40" w
FC-WM-48KV	2 Stations, 48" w
FC-WM-60KV	3 Stations, 60" w
FC-WM-72KV	3 Stations, 72" w
FC-WM-80KV	4 Stations, 80" w
FC-WM-96KV	4 Stations, 96" w
FC-WM-100KV	5 Stations, 100" w
FC-WM-120KV	6 Stations, 120" w

MANUAL FAUCETS INCLUDED

FC-WM-40-F	2 Stations, 37" w
FC-WM-48-F	2 Stations, 48" w
FC-WM-60-F	3 Stations, 60" w
FC-WM-72-F	3 Stations, 72" w
FC-WM-80-F	4 Stations, 80" w
FC-WM-96-F	4 Stations, 96" w
FC-WM-100-F	5 Stations, 100" w
FC-WM-120-F	6 Stations, 120" w



BK RESOURCES

BK RESOURCES

Marine Edge Mobile Soak Sink

- Mobile design for easy transport to any prep or warewashing area
- Heavy-duty 16 gauge T-304 stainless steel construction for lasting durability
- Marine edge contains splashes and overflows for a safer, cleaner workspace
- Corner bumpers protect walls and equipment from impact during movement
- Includes 5" casters with top-lock brakes
- Features a twist lever drain for quick and efficient water removal
- 1-year warranty

BKS-1-SK-20-8-ME 26½" w x 26½" d x 21¼" h

Compartment Sinks

- Heavy-duty 18 gauge, T-304 stainless steel construction
- Features an integrated 9" high backsplash to protect walls
- Galvanized steel legs provide stable support with adjustable bullet feet
- 1½" rolled front and side edges contain spills and add rigidity
- Includes 8" on-center holes for splash-mount faucets
- 1-year warranty



	BOWL(S)	DRAINBOARD(S)	DIMENSIONS
BKS-1-18-12	1	—	23½" w x 23¾" d x 43¾" h
BKS-1-18-12-18L	1	1 Left	38½" w x 23¾" d x 43¾" h
BKS-1-18-12-18R	1	1 Right	38½" w x 23¾" d x 43¾" h
BKS-2-1620-12-18R	2	1 Right	52½" w x 25¾" d x 43¾" h
BKS-3-18-12-18T	3	1 Left, 1 Right	90" w x 23¾" d x 43¾" h



Powerful dish washing.



Conveyor System

- Automates soiled tray return in high-volume cafeteria dish rooms
- Features patented slanted rollers on slats attached to a stainless steel chain for frictionless operation and easy removal at turns
- Gapless, reticulating slats to prevent food traps and utensil jams
- Uni-body stainless steel construction (including drive motor)
- Includes a tension hub drive that slips during jams to protect components
- Auto-tensioning system reduces chain wear for long-term reliability

Self-cleaning return tracks

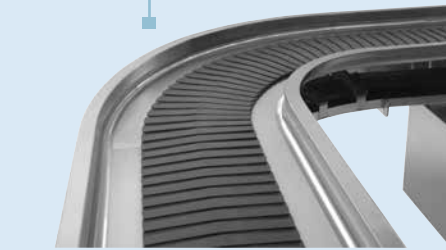

CBSW



TIP

The 3-Compartment Sink Method

Follow these 5 steps for proper washing, rinsing and sanitizing in a 3-compartment sink:

1. Scrape leftover food from dishes
2. Place dishes in Sink 1 and scrub in warm, soapy water at a minimum temperature of 110°F
3. Transfer scrubbed dishes to Sink 2 for rinsing. Rinse the dishes in clean, warm water at a minimum temperature of 110°F
4. Sanitize the dishes in Sink 3 by soaking the dishes in a chemical sanitizing solution. Refer to the instructions of the sanitizer manufacturer for use and duration of submergence
5. Allow dishes to air dry to prevent recontamination



14-gauge 304 stainless steel

Vortex Wash System

- Powerful 3 hp wash system
- Three-sink design
- Integrated drainboards
- High backsplash
- 1-year parts and labor warranty on pumps and control panel



VWS





Diamond Series Pre-Rinse Unit with 12" Add-On Faucet



- Designed for high-performance pre-rinse applications
- Features a solid brass base with an ultra-polish satin finish
- Includes a dual spray head with rotating knife and cyclone patterns
- Combines a stainless steel hyperflex hose, dura-spring and smooth-spin swivel to reduce wear
- ¼ turn ceramic cartridge valves with integral checks prevent backflow
- Delivers a water-efficient 1.15 GPM flow rate
- Arrives pre-assembled with mounting kit and supply lines for faster installation
- Lifetime warranty

DX-109 8" Center Wall Mount Pre-Rinse, 12" Swing Spout, 38" h with 15" overhang, 44" hose
DX-129 Adjustable Spray Head, 3 3/8" w x 9 3/4" h



Stainless Steel Compartment Sinks

- Fabricated from 304 series stainless steel
- Rolled front and side edges with a 9 3/4" backsplash
- Stainless steel legs and H-shaped cross-bracing
- 1" adjustable stainless steel bullet feet
- Pre-punched to accept an 8" on-center deck-mount faucet
- Includes a drain basket for the 3/2" IPS drain connection

Size	BOWL(S)	DRAINBOARDS	DIMENSIONS
16" x 20" x 12"D			
SWS1C151512-318	1	—	20" w x 20 1/2" d x 43 3/4" h
SWS1C162012-18L-318	1	18" Left	36 1/2" w x 25 1/2" d x 43 3/4" h
SWS1C162012-18R-318	1	18" Right	36 1/2" w x 25 1/2" d x 43 3/4" h
SWS1C162012-18LR-318	1	18" Left & Right	52" w x 25 1/2" d x 43 3/4" h
24" x 24" x 14"D			
SWS1C242414-316	1	—	29" w x 29 1/2" d x 43 3/4" h
SWS1C242414-18L-316	1	18" Left	44 1/2" w x 29 1/2" d x 43 3/4" h
SWS1C242414-18R-316	1	18" Right	44 1/2" w x 29 1/2" d x 43 3/4" h
SWS1C242414-18LR-316	1	18" Left & Right	60" w x 29 1/2" d x 43 3/4" h
16" x 20" x 12"D			
SWS2C162012-318	2	—	37" w x 25 1/2" d x 43 3/4" h
SWS2C162012-18L-318	2	18" Left	52" w x 25 1/2" d x 43 3/4" h
SWS2C162012-18R-318	2	18" Right	52" w x 25 1/2" d x 43 3/4" h
SWS2C162012-18LR-318	2	18" Left & Right	68" w x 25 1/2" d x 43 3/4" h
16" x 20" x 12"D			
SWS3C162012-318	3	—	53" w x 25 1/2" d x 43 3/4" h
SWS3C162012-18L-318	3	18" Left	68" w x 25 1/2" d x 43 3/4" h
SWS3C162012-18R-318	3	18" Right	68" w x 25 1/2" d x 43 3/4" h
SWS3C162012-18LR-318	3	18" Left & Right	84" w x 25 1/2" d x 43 3/4" h



3 Compartment Soiled Dishtables

- Designed with 3 sink compartments for sorting, scraping and pre-rinsing
- Constructed from heavy-duty 16-gauge, 304 series stainless steel
- Features a 7 1/2" high backsplash
- 1" adjustable stainless steel bullet feet for leveling on uneven floors
- Pre-punched with 8" on-center faucet holes for easy faucet installation
- 90" w x 30" d x 41 1/2" h

SWDTC-3-90L Left
SWDTC-3-90R Right





ULTRARINSE™ Wall Mount Mixing Faucet

- Features the patented UltraRinse spray arm, designed for rinsing produce and thawing foods to promote food safety, reduce food damage and cut waste
- 1.5 GPM multiple tip sprayer arm with diverter cartridge switches between nozzle & sprayer arm
- Polished chrome-plated brass body
- 12" swing nozzle with stream regulator
- Lever handles with color coded indexes



B-0231-U12 8" Centers



Open Hose Reel

- Includes a 15' heavy-duty, non-marking hose rated to 300 PSI
- Ratcheting system holds hose at any length and retracts with a slight tug
- Multi-fit bracket provides versatile wall, ceiling or under-counter mounting
- Equipped with a high-flow spray valve
- 2-year limited warranty



B-7212-01 15' l x 3/8" dia Hose

Heavy Duty Dishtables

- 16-gauge T-304 stainless steel top, legs and bracing
- Features an integrated 10" h backsplash
- Raised rolled front and side edges
- Adjustable bullet feet
- 48" l x 30 3/4" w x 46 1/4" h
- 1-year warranty



BKSDT6-48-L-SS Left Side Soiled Table
BKCDT6-48-R-SS Right Side Clean Table



EasyInstall Pre-Rinse Unit

- 1.07 GPM spray valve w/swivel
- 1/2" NPT female inlets with 2" flanges
- 14" swing nozzle w/2.2 VR aerator, Series 6 (B-0199-06)
- 44" flexible stainless steel hose w/heat resistant gray handle and hold down ring
- 6" adjustable wall bracket
- 8" wall mount mixing faucet
- Accessory fitting tee
- EasyInstall add-on faucet
- Quarter-turn Cerama cartridges w/check valves to prevent cross flow of water
- Quick disconnect

B-0133-14CRQJST 8" Centers



Features a polished chrome plated brass body

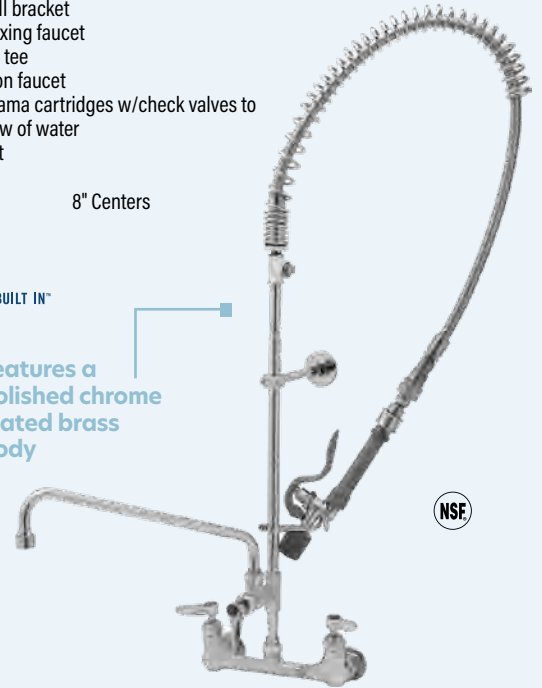

Hand Wash Sink

- Stainless steel sink with side splash shields and 4" wall mount mixing faucet
- 4 3/8" rigid gooseneck faucet
- 2.2 GPM aerator and ceramic cartridges with check valves
- Includes lever handles with color-coded indexes

B-1146-02A-CR-4W-S 17" l x 15" w



Clean Dishtables

- Features a 16-gauge, 304-series stainless steel top
- Supported by 18-gauge, 202-series stainless steel legs and H-shape cross-bracing
- 9" h backsplash to protect walls from water splashes
- Stainless steel legs with adjustable stainless steel bullet feet



SWCDT-26L	26" w, Left	SWCDT-48R	48" w, Right
SWCDT-26R	26" w, Right	SWCDT-60L	60" w, Left
SWCDT-36L	36" w, Left	SWCDT-60R	60" w, Right
SWCDT-36R	36" w, Right	SWCDT-72L	72" w, Left
SWCDT-48L	48" w, Left	SWCDT-72R	72" w, Right





Power Soak Systems

- Continuous motion warewashing system
- Rotating water flow delivers clean wares
- Heated wash tank maintains a constant 115°F
- Increases warewashing output and consistency
- Configuration of units left to right: 1" End Splash, 6" Soiled Drain Board, 12" Scrap Sink, Wash Tank (36" x 21"), 20" x 14" Rinse Tank, 20" x 14" Sanitizer Tank, 18" Clean Drain Board, 1" End Splash
- 208/60/3
- Right to Left configurations available
- 3-year parts and labor warranty

PSA-S-114L-208-3 114"w x 36"d x 44½"h



PSA-S-126L-208-3

Clean like a pro.

Patented, gentle wash action

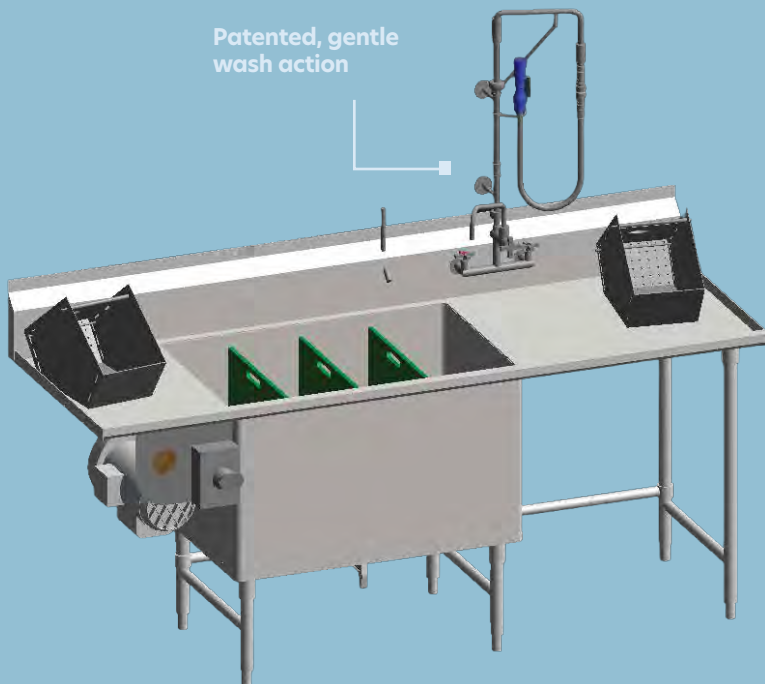

Power Prep Advanced Systems

- Self-loading baskets automate product removal
- Multi-function design efficiently washes produce and thaws frozen proteins
- Hands-free removal process minimizes direct contact to reduce cross-contamination
- Right to Left flow available
- 3-year parts and labor warranty

PPA4B-84L-208-1 84"w, 4 Bays, Left to Right Flow



Dependable Wash Stations

Keep operations running smoothly with John Boos warewashing solutions designed for durability, efficiency and consistent performance. Built from commercial-grade stainless steel, these products are engineered to handle high-volume cleaning while supporting sanitation standards in fast-paced kitchen environments.

BOOS
STEEL



Dishtables

Create a seamless warewashing line with John Boos Pro-Bowl dishtables, designed for efficient left-to-right operation in high-volume kitchens. This setup includes a soiled dishtable with integrated pre-rinse sink, a clean dishtable for unloading and a wall-mounted dishrack sorting shelf to streamline workflow. Constructed from durable stainless steel with boxed backsplashes, rolled edges and adjustable legs, each component is built for long-lasting commercial performance.

Pro-Bowl 3-Compartment Sink

3PB244-2D30

Designed for high-volume warewashing, this 3-compartment sink delivers a complete wash, rinse and sanitize solution in one durable unit. Measuring 135 $\frac{1}{4}$ "w x 29 $\frac{1}{2}$ "d x 44 $\frac{1}{16}$ "h, it features three 24" x 24" x 14" bowls, dual 30" drainboards and a 10" high boxed backsplash. Constructed from stainless steel with adjustable bracing and bullet feet, this setup includes heavy-duty faucets, pre-rinse unit with add-on faucet, lever waste drains and mounting kits.

All-Purpose Plastic Storage Tubs

- Virgin grade material resists bacteria, mold and mildew
- Features integrated ergonomic handles for comfortable transport
- Nests when empty to save valuable storage space
- Available in Brown (BN), Black (BK) and Gray (GY)
- FSB-20155R is also available in Blue (BL)



FSB-20155GY

FSB-20155RBL

FSB-21157RBK

FSB-21165GY

FSB-20113BN

Heavy-duty polypropylene construction

1 COMPARTMENT

- FSB-1295** 12 $\frac{1}{8}$ "l x 9 $\frac{1}{8}$ "w x 5 $\frac{1}{8}$ "h
- FSB-1544** 14 $\frac{3}{8}$ "l x 4 $\frac{3}{8}$ "w x 4 $\frac{3}{8}$ "h
- FSB-20155** 20"l x 15"w x 5"h
- FSB-21155** 21"l x 15"w x 5"h
- FSB-21157** 21"l x 15"w x 7"h
- FSB-22175** 22"l x 17"w x 5"h

2 COMPARTMENTS

- FSB-21165** 20"l x 15"w x 5"h

4 COMPARTMENTS

- FSB-20113** 20 $\frac{1}{8}$ "l x 11 $\frac{1}{8}$ "w x 3 $\frac{3}{4}$ "h

LIDS

- FSB-L2016** 20 $\frac{1}{8}$ "l x 15 $\frac{3}{4}$ "w, Fits FSB-20155
- FSB-L2115** 20 $\frac{1}{8}$ "l x 15 $\frac{3}{4}$ "w, Fits FSB-21155, FSB-21157
- FSB-L2115R** 21 $\frac{1}{2}$ " x 15 $\frac{3}{4}$ "w, Fits FSB-21155R, FSB-21157R
- FSB-L2216** 22"l x 16 $\frac{1}{2}$ "w, Fits FSB-20155R
- FSB-L2217** 22"l x 16 $\frac{1}{8}$ "w, Fits FSB-22175

1 COMPARTMENT - RIBBED BOTTOM

- FSB-20155R** 20"l x 15"w x 5"h
- FSB-21155R** 21"l x 15"w x 5"h
- FSB-21157R** 21"l x 15"w x 7"h
- FSB-22177R** 21 $\frac{1}{2}$ "l x 17"w x 7"h



P914

SALVAJOR FOOD WASTE SOLUTIONS

Food Waste Collectors

- Collectors wash soluble foods harmlessly through the sewers, reducing bulk waste by as much as 50%
- The Trough Collector™ recirculates 70 gallons of water per minute
- Scrap Collectors™ recirculate 30 gallons of water per minute
- Only consumes 2 gallons per minute
- Ideal for areas where disposers are prohibited, safe for use with grease interceptors or septic systems
- 115/208/230V, 1 Phase or 208/230/460V, 3 Phase

S914



S419



WITH TROUGH

S419 Trough Collector™

NON-TROUGH

S914 Scrap Collector™
P914 Pot/Pan Collector™

SALVAJOR FOOD WASTE SOLUTIONS



TroughVeyor®

- Uses recirculated water to propel food down the trough at 70 gallons of water per minute
- Uses only 7 gallons of water per minute
- Recommended trough width 12"
- HydroLogic Water Saving Control
- 5 hp



500-TVR Right
500-TVL Left



SALVAJOR FOOD WASTE SOLUTIONS

Food Waste Disposers

- Heavy duty, corrosion-resistant heat-treated aluminum housing
- Models 100 & 200 fit easily under a 14" deep sink, Model 300 requires a short top housing
- Water cooled motor
- Packages include disposer, control panel, 1/2" solenoid valve, 1/2" fixed nozzle, 1/2" vacuum breaker, flow control, sink stopper and a sink mounting collar (specify 3/2" or 6 1/2")



- 100-SA-MSS** 1 hp, Non Reversing, MSS Control
- 200-SA-MSS** 2 hp, Non Reversing, MSS Control
- 300-SA-WSP** 3 hp, w/Water Savings Package, ARSS-LD Control

Reliable waste disposal.



SALVAJOR FOOD WASTE SOLUTIONS



ScrapMaster®

- Consumes only 7 gallons of water per minute while the powerful pre-flushing plume recirculates at a 30 gallon rate
- Scrapping speed is more than doubled for greater efficiency
- Stainless steel components
- Adjustable legs
- HydroLogic Water Saving Control
- 5 hp

500-SM Standard Scrap Basin
500-PSM Pot/Pan Scrap Basin



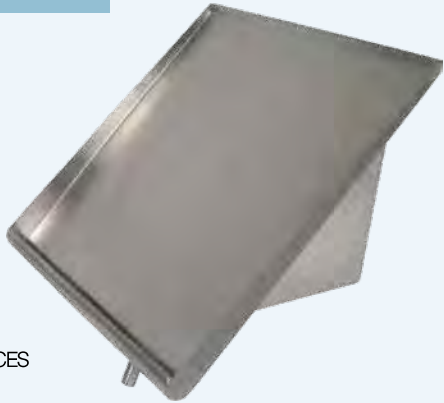

BK RESOURCES

Stainless Steel Slant Rack Drying Shelf

- Wall-mounted slant rack design promotes air circulation for faster drying
- Constructed from 18-gauge, T-304 stainless steel
- Features a rolled front edge for added safety and reinforcement
- Includes mounting brackets for secure and simple installation
- Holds (2) 20" x 20" glass racks

BK-SSH-42

42"l x 22"w



BK RESOURCES

Dish Cabinet

- Open-front cabinet holds up to 700 lb
- Type 304, 14-gauge stainless steel top and 18-gauge stainless steel body
- Includes a fixed position shelf to maximize storage capacity
- 6" stainless steel legs with adjustable bullet feet
- 1-year warranty

6" stainless steel legs with adjustable feet

BKDC-1572

72"w x 15"d x 34¾"h



Store clean wares safely.



MetroMax® 4 Mobile Drying Racks

- Combine the corrosion protection and strength of MetroMax® 4 with the convenience of a drying rack
- Superior air circulation promotes fast drying of trays, cutting boards, pans, lids, pots and all sink items
- Includes shelves, mobile posts, casters and accessories as designated below
- Shelf mats have built-in Microban® antimicrobial product protection
- Corrosion-resistant polymer horn casters (2 swivel, 2 brake)



MAX4-PR36VX2



THREE TRAY RACKS	DIMENSIONS	SHELVES	CAPACITY
MAX4-PR36VX2	36"l x 24"w x 68"h	3	600 lb
MAX4-PR48VX2	48"l x 24"w x 68"h	3	600 lb

TWO STAINLESS STEEL DROP-INS, ONE TRAY RACK, ONE BULK SHELF	DIMENSIONS	SHELVES	CAPACITY
MAX4-PR36VX3	36"l x 24"w x 68"h	4	750 lb
MAX4-PR48VX3	48"l x 24"w x 68"h	4	750 lb

TWO TRAY RACKS, TWO PAN RACKS	DIMENSIONS	SHELVES	CAPACITY
MAX4-PR36VX4	36"l x 24"w x 68"h	4	750 lb
MAX4-PR48VX4	48"l x 24"w x 68"h	4	750 lb



Flat Top Dish Cabinets

- Combines a heavy-duty work surface with versatile enclosed storage
- 16 gauge 304 stainless steel top with bull nose front edge and 18 gauge body
- Reinforced top with sound-deadening hat channel supports for top, intermediate and bottom shelves
- Includes an adjustable stainless steel middle shelf for customized storage
- Stainless steel legs with adjustable bullet feet
- All exposed welds are polished smooth for easy cleaning and sanitation

	DIMENSIONS	STYLE
SMDC-1536	36" w x 15" d x 35½" h	Open Front
SMDC-1548	48" w x 15" d x 35½" h	Open Front
SMDC-1560	60" w x 15" d x 35½" h	Open Front
SMDC-2436S	36" w x 24" d x 35½" h	Sliding Doors
SMDC-2448S	48" w x 24" d x 35½" h	Sliding Doors
SMDC-2460S	60" w x 24" d x 35½" h	Sliding Doors
SMDC-2418H	18" w x 24" d x 35½" h	Solid Hinged Door
SMDC-2424H	24" w x 24" d x 35½" h	Solid Hinged Door
SMDC-2436H	36" w x 24" d x 35½" h	Solid Hinged Door

Other styles & sizes are available.



Champion

High Temp Door Type Dish Machine

- Washes up to 55 racks per hour
- Rinse Sentry ensures a sanitizing 180°F final rinse
- Auto-start feature
- High-efficiency 1 hp pump
- Field convertible to single or three phase, 208 or 240V, corner or straight through operation
- 1-year parts and labor warranty

DH-3000 31 $\frac{1}{8}$ "w x 28 $\frac{3}{8}$ "d x 63 $\frac{3}{4}$ "h



Touchscreen controls



Efficiency in every cycle.

Ventless Heat Recovery Door Type Dish Machine

- High temp dish machine with built-in booster heater and Ventless Heat Recovery
- HMI - Operator Touch Screen Interface
- Field convertible
- Energy-saving Sleep Mode ensures all internal heaters shut off after 4 hours idle
- Door Interlock locks door closed during the vent fan cycle
- Washes 40 racks per hour
- Auto start
- High efficiency 2 hp pump
- Self-draining pump
- 4 selectable cycles
- Field convertible to single or three phase, 208 or 240V, corner or straight through operation
- 1-year limited parts and labor

DH-6000T-VHR 21 $\frac{1}{8}$ "w x 24 $\frac{1}{4}$ "d x 79 $\frac{1}{16}$ "h



Extended hood with 27" opening for trays



Champion



WAREWASHING



Champion



On-board diagnostics identify machine faults to reduce service calls and downtime

Pro Series 44 High Temp Rack Conveyor Dishwashers

- Automated rack conveyor system for high-volume dishwashing operations
- Processes up to 209 racks per hour using only 0.48 gallons of water per rack
- Features an advanced touchscreen display with intuitive, multi-lingual controls
- Heavy gauge stainless steel construction including the base, legs and feet
- Equipped with a 2 hp pump motor and durable stainless steel impeller
- Energy Sentinel idle pump shut-off reduces utility consumption
- 208/240V
- 1-year limited parts and labor

44 PRO 48" w x 26 $\frac{1}{2}$ " d x 65" h
44 PRO-VHR Ventless Heat Recovery, 60" w x 32 $\frac{1}{2}$ " d x 89" h



EST-VL

Ventless heat recovery system eliminates costly external hood installation



Ventless Upright Dish Machines

- Features all-stainless steel construction for corrosion resistance and longevity
- High Temperature models are equipped with a 1 hp wash pump, 6kW wash tank heater, and 12kW booster heater and sanitize with a 180°F final rinse
- Chemical Sanitizing models feature built-in chemical pumps for sanitizing
- 208/240V

CHEMICAL SANITIZING	RACKS/HR	DIMENSIONS
EST-VL	30	25" w x 29 $\frac{1}{2}$ " d x 85 $\frac{1}{2}$ " h
HIGH TEMPERATURE		
180-VL	40	25 $\frac{1}{2}$ " w x 29" d x 85 $\frac{1}{2}$ " h
180-VL TALL	40	25 $\frac{1}{2}$ " w x 29" d x 95 $\frac{1}{2}$ " h
FRONT LOAD		
180-VL FL	20	25 $\frac{1}{2}$ " w x 29" d x 85 $\frac{1}{2}$ " h



180-VL

Consistent shine every time.

High Temp Undercounter Dishwasher

- High-temperature sanitizing for up to 25 racks per hour
- Shear Energy technology reduces energy requirements while maximizing performance
- Multi-Power feature allows for easy infield conversion to 208-240V or single/3 phase power
- Built-in booster heater with Rinse Sentry ensures a sanitizing 180°F final rinse
- StemSure™ soft start protects delicate glassware from chipping or breaking
- Double-wall stainless steel construction
- 1 hp
- 1-year parts and labor warranty



UH130BMAX 24"w x 25"d x 33¾"h



Wash Refresh™ automatically drains and refills water for a fresh wash cycle



Crystal clean for sparkling results.



Pot Washer

- High-temperature washer cleans oversized pots and full-size pans
- Large, 31¼" opening
- Four automatic cycles: 5, 6, 8 or 10 minutes
- Upper and lower stainless steel wash arms
- Integrated booster heater
- Uses only 1.1 gal per cycle

PT-15 27¼"w x 31½"d x 90¼"h



Low Temp Undercounter Dishwasher

- Consumes only 1.19 gallons of water per cycle and washes up to 40 racks per hour
- Features all stainless steel construction
- Includes upper and lower stainless steel spray arms for a complete wash
- Pumped drain enables flexible installation without requiring a floor drain

L-1XE 24"w x 23½"d x 33¾"h



Built-in chemical pumps and prime switches ensure proper chemical usage





Undercounter High Temperature Dishwasher

- Hot water sanitizing
- Safe-T-Temp feature guarantees a 180°F final rinse
- Up to 30 racks/hour capacity
- 14½" maximum clearance for wares
- Automatic fill
- 6kW booster heater
- 5kW wash tank heater

180UC-3 24"w x 25"d x 33¾"h

Sanitized to perfection.



Ventless High-Temp Glasswasher

- Perfect for the bar or kitchen
- Uses cold water only, significantly reducing energy costs
- Soft Start feature protects delicate stemware and glassware
- Heat Recovery System promotes faster drying
- Stainless steel construction
- Safe-T-Temp booster heater for a 70°F rise
- 1 hp wash pump and stainless steel upper and lower wash and rinse arms
- 208/240V

181 VL 20 Racks Per Hour, 24"w x 27"d x 33¾"h



High-Temperature Undercounter Dishwashers



- Stainless steel exterior
- Soap and rinse pumps included
- Booster heaters are integrated into every Lamber dishwasher
- 1-year parts and labor warranty, F99EKDPS features a 2-year parts and labor warranty



16" X 16" RACK

DSP3

DSP3DPS

30 Racks/hr, 11¾" Plate Clearance, Gravity Drain, 4 gal Tank

30 Racks/hr, 11¾" Plate Clearance, Drain Pump, 4 gal Tank

20" X 20" RACK

DSP4DPS

F99EKDPS

30 Racks/hr, 12" Plate Clearance, Drain Pump, 4.8 gal Tank

30/20/15 Racks/hr, 14½" Plate Clearance, Drain Pump, 4.8 gal Tank



RackStar® 44 Conveyor Dishwasher

- Cleans and sanitizes 224 racks per hour
- Durable stainless steel construction
- 19¾" clearance
- Adjustable Rainbow Rinse - choose Econo or Turbo mode
- Self-cleaning wash arms
- Fully automatic, including auto-fill
- Exclusive EnergyGuard™ controls
- Digital LED control panel
- Delime cycle
- Splash shields and table limit switch come standard
- One of the lowest cost of ownership in the industry
- 1-year parts and labor warranty



RACKSTAR 44 64" w x 30" d x 68½" h



TempStar® High Temperature Door Type Dishwasher

- Cleans 63 racks per hour with 0.89 gallons per rack
- Features durable stainless steel construction
- Built-in 70°F rise booster with an exclusive Sani-Sure™ final rinse system for guaranteed sanitation
- Offers 4 selectable timed cycles
- 208/230V
- 1-year parts and labor warranty



TEMPSTAR 32" w x 29" d x 64¾" h

DynaStar® High Temperature Door-type Dishwasher

- Washes up to 62 racks per hour
- Energy saving, uses only 0.70 gallons of water per rack
- Durable stainless steel construction
- Features a built-in booster heater with Sani-Sure™ final rinse system
- 3 selectable timed cycles and a dedicated delime cycle
- Digital LED display
- Field convertible from straight-through to corner installation
- Tall chamber models are dual-certified as both a dishwasher and a potwasher
- Available with Ventless and Energy Recovery
- 1-year parts and labor warranty

DYNASTAR 28¾" w x 34" d x 62½" h



High heat, high performance.



High Temperature Door-Type Dishwasher

- Cleans 63 racks per hour using only 0.89 gallons of water per rack
- Built-in booster heater with Sani-Sure™ final rinse system
- Stainless steel construction and nozzles
- Interchangeable upper and lower wash/rinse arms
- 17¾" clearance
- Single cycle operation
- Digital temperature display
- Adjustable bullet feet
- 208/230V
- 1-year parts and labor warranty



NXP-HTD 30¾" w x 29" d x 64" h



DishStar® HT High Temperature Undercounter Dishwasher

- Fill and dump design cleans 30 racks per hour using only 1.1 gallons per rack
- Built-in booster heater with Sani-Sure™ final rinse system
- Includes solid-state controls with timed cycles and a digital LED temperature display
- Offers simple push-button start with an automatic fill feature
- Equipped with built-in chemical pumps and an automatic pumped drain
- Stainless steel construction with a fully insulated cabinet
- 14¼" clearance
- 1-year parts and labor warranty

DISHSTAR HT
24¼" w x 25" d x 33¾" h

Jackson



Simplifies maintenance with a built-in delime cycle

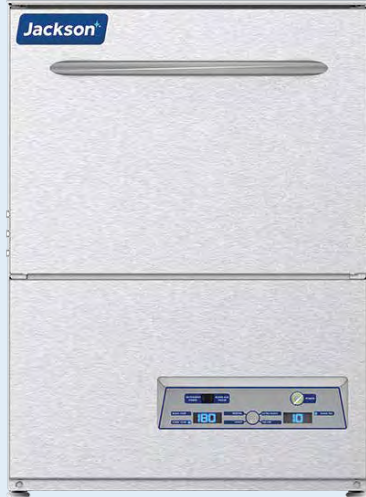

Delta® SEER High Temperature Sanitizing Glasswashers

- Features a Steam Elimination and Energy Recovery System (SEER) for front-of-house use
- Cleans up to 864 glasses per hour using just 0.6 gallons of water per rack
- Operates on a single cold water (40° to 90°F) connection by recycling steam to preheat rinse water
- Built-in booster heater with Sani-Sure™ final rinse system
- Soft Start system protects delicate glassware from chipping and breaking
- Accommodates tall stemware with a 12" clearance and standard 20"x 20" racks
- 1-year parts and labor warranty

DELTA HT-E-SEER 24¼" w x 26⅞" d x 28¾" h
DELTA HT-E-SEER-S Short, 24¼" w x 26⅞" d x 36¼" h
DELTA HT-E-SEER-T Tall, 24¼" w x 26⅞" d x 41¼" h



Delta® 115 Low Temperature Rotary Glasswasher

- Cleans up to 1,200 glasses per hour with a rotary conveyor system
- Composite carousel conveyor prevents chipping and damage to glassware
- 12" clearance to accommodate taller stemware and mugs
- Stainless steel construction on wash arms, rinse arms and manifold
- Includes built-in chemical pumps with convenient interior storage
- Single-switch, auto-fill design
- Adjustable bullet feet
- 115V
- 1-year parts and labor warranty

DELTA 115 25¼" w x 25¼" d x 39" h

Jackson



Jackson

Delta® 5-E Low Temperature Door-Type Glasswasher/Dishwasher

- Cleans 39 racks per hour with only 1.15 gallons per rack
- Durable stainless steel construction with adjustable bullet feet
- Push-button start with electronic timer and accessible controls
- Features built-in chemical pumps and priming switches
- Upper and lower wash and rinse system delivers complete coverage
- Designed for underbar placement with convenient waist-level controls
- Utilizes a gravity drain system
- 11½" Clearance
- 1-year parts and labor warranty

DELTA 5-E 24" w x 25¼" d x 39" h



Ready for the next round.



High-Temperature Door-Type Dishmachine

- Cleans up to 60 racks per hour
- Uses only 0.76 gal per rack
- Varicycle setting extends wash time for heavily soiled wares
- Intuitive, 4.3" color display with on-board diagnostics
- Automatic start
- Automatic delimer
- Low water tank heat protection
- Field convertible to 208 or 240V
- 1-year parts and labor warranty



MD2000-PLUS 31 $\frac{1}{2}$ "w x 30 $\frac{3}{4}$ "d x 63 $\frac{3}{4}$ "h



The perfect pour starts here.

Undercounter High Temperature Dishwasher with Freshwater Rinse

- Cleans up to 30 racks per hour
- Sanitizes dishware with a 180°F freshwater final rinse
- Uses just 0.84 US gal of water per rack
- Intuitive LCD control display for clear temperature and cycle monitoring
- Automatic pumped drain
- Auto Clean cycle washes the chamber at shutdown
- 208/240V, 1 hp
- 1-year parts and labor warranty

383HT 24"w x 25"d x 33 $\frac{1}{2}$ "h



Glasswasher

- Rotary type, fully automatic with integrated tank and wash chamber
- Washes up to 1200 glasses per hour
- Double-wall stainless steel construction for quiet operation
- Polypropylene conveyor with touchless shut-off sensor prevents chipping of delicate glassware
- Low/medium/high speed function
- Upper and lower wash and rinse arms
- Three-pump injection system automatically dispenses precise chemical amounts
- Cool water final rinse ensures glasses are ready for use
- 1-year parts and labor warranty



DF REVOLUTION 23 $\frac{3}{8}$ "w x 24 $\frac{1}{2}$ "d x 39"h

Cool water final rinse ensures glasses are ready for use



Ventless Heat Recovery Extended Hood-Type Door Machine

- Ventless heat recovery system eliminates the need for a separate ventilation hood
- Features a 27" extended hood clearance for oversized pots, pans and wares
- Cleans up to 40 racks per hour using an efficient 0.73 gallons of water per rack
- Advanced touchscreen display offers intuitive operation and on-board diagnostics
- Rinse Sentry feature ensures the final rinse reaches optimal sanitization temperature
- Field convertible for single or 3 phase power and pass-thru or corner installations
- ENERGY STAR® certified with a programmable energy-saving sleep mode
- 208/240V, 2 hp
- 1-year parts and labor warranty

MDHHD-VL 34"w x 31"d x 79 $\frac{1}{8}$ "h





Keeg Coolers

- Textured, baked black enamel finish exterior, stainless steel countertop, interior back and side panels with reinforced stainless steel floor
- Continuously cooled 3" diameter beer columns with lever faucets CO2 pressure relief distributor and keg line tubing with clamps
- Easily removable stainless steel drip grate with convenient front mounted clean out drainage hose
- Cylinder-keyed security lock and magnetic snap-in gasket on each door
- Easily accessible and serviceable slide-out condensing unit
- Readily removable front, rear and side venting louvered grills
- Automatic, hot gas condensate evaporator
- Extra large, balanced evaporator coil
- 29³/₁₆"d x 34³/₄"h
- Made in the USA

	BEER COLUMNS	KEG CAPACITY*	WIDTH	HP
KC24N	1	1	24"	1/8
KC50N	1	2	50"	1/4
KC59N	2	3	59"	1/4
KC69N	2	3	69"	1/4

*Keg capacity based on straight wall kegs



BB69NSS

Back Bar Coolers

- Stainless steel top and exterior with stainless steel interior back and side panels and a reinforced stainless steel floor
- Epoxy-coated steel shelves
- LED interior lighting
- Automatic, hot gas condensate evaporator
- High density, non-CFC polyurethane foamed-in-place insulation
- Natural, environmentally-safe, high-efficiency R-290 refrigerant
- Extra large, balanced evaporator coil
- 29³/₁₆"d x 34³/₄"h
- Made in the USA

	DOORS	SHELVES	WIDTH	KEG CAPACITY*	HP
BB24NSS	1	2	24"	1	1/8
BB50NSS	2	4	50"	2	1/4
BB59NSS	2	4	59"	3	1/4
BB69NSS	2	4	69"	3	1/4

*Keg capacity based on straight wall kegs



Performance on tap.



BREW CAVE
BY U.S. COOLER



Brew Cave® by U.S. Cooler®

No matter how large or small the project, Brew Cave® will build the modular refrigerated building to suit your needs. Whether you need to store ingredients, supply your tap room, or chill kegs and cases for shipment, Brew Cave® will deliver. We design custom walk-in coolers and freezers of all shapes and sizes to conform to your brewery's layout and storage needs.

- 4" thick modular panels
- High R-value insulation
- Efficient refrigeration systems
- Large doors for forklifts available
- Over 20 color options
- Panels are UL and NSF Approved
- EISA Compliant



Front Door Mug Freezers

- Compact underbar freezer designed for chilling up to (90) 10 oz glasses and mugs
- Exterior available in stainless steel or black vinyl finish
- Optional 1" stainless steel top adds an additional 1" to height
- Stainless steel interior with coved corners, 2 wire racks and floor rack
- Includes a self-closing, locking door to secure contents
- Maintains a consistent operating temperature between -3° and 7°F
- Features a ½ hp refrigeration system using eco-friendly R-290 refrigerant
- Automatic evaporator coil defrost cycle runs every 4 hours
- Built-in condensate evaporator pan eliminates the need for a floor drain
- Front-facing digital thermostat
- Pre-drilled bottom for optional casters
- 2-year parts and labor warranty, 5-year compressor warranty
- Additional models and configurations available

FMC24 24" w x 24" d x 35" h

KROWNE®



FMC24-BS-L



FMC24-SN-L



Back Bar Cooler

- Compact, self-contained refrigerated storage in your choice of stainless steel or black vinyl exterior
- Stainless steel interior with coved corners
- Maintains temperatures from 30° to 40°F with DynamicChill 360° technology
- Includes heavy-duty self-closing doors with integrated locks
- Built-in cool white 7000K LED lighting
- Heated mullion minimizes condensation to maintain product visibility
- Utilizes an eco-friendly R-290 hydrocarbon refrigerant system
- Pre-drilled bottom for optional legs or casters
- 115V
- 2-year parts and labor warranty, 5-year compressor warranty
- Other models and configurations available

BS24 24" w x 24" d x 35" h

KROWNE®



Chilled to perfection.

KROWNE®

Low Profile Back Bar Coolers

- Maintains 30° to 40°F temperatures with DynamicChill 360° technology
- 20 gauge stainless steel exterior and interior with coved corners
- Illuminates contents with built-in cool white LED lighting
- Equipped with self-closing, locking doors
- R-290 refrigerant
- 115V
- 2-year parts and labor warranty, 5-year compressor warranty
- Other options and configurations available

LS60 60" w x 24" d x 29" h



LS60R-KSS



LS60L-BSS

Glastender.

Cocktail Prep Cooler

- Refrigerated mixology well, garnish station, plus storage for a one-of-a-kind cocktail prep station
- Stainless steel interior and exterior construction resists corrosion
- Self-contained refrigeration system uses R-290 refrigerant
- Refrigerated garnish rail top with (6) ½ size pans and lids
- Includes a refrigerated locking bottle drawer for secure inventory management
- Made in USA

CPC24 24" w x 24" d x 37" h



Drink rail features a perforated insert and removable cutting board



Glastender.

High Profile Coolers

- Elevate best-sellers and seasonal beverages with these eye-catching merchandisers
- Your choice of attractive exterior finishes in stainless steel, black vinyl-clad, laminate or wood panel-ready, solid or glass doors and one or two zones for added flexibility
- Bright, efficient LED interior lighting illuminates contents
- Offers customized organization with 6 adjustable shelves or optional pull-out wine shelves
- 24" w x 24" d x 75" h

C1TH24F 1 Door, 1 Zone
 C1TH24H 2 Half-Size Doors, 1 Zone
 C2TH24H 2 Half-Size Doors, 2 Zones



C1TH24F

Glastender.

Reach-In Froster

- Side-serviced reach-in froster designed for underbar applications
- Features a self-contained refrigeration system with a ½ hp compressor
- Stainless steel interior and exterior sub-top provides added durability
- R-290 hydrocarbon refrigerant
- Energy-efficient LED interior lighting enhances product visibility
- 3 adjustable shelves or 2 drawers for versatile storage

FISB24 24" w x 24" d x 35" h



Front-venting design allows for zero-clearance installation



Beechwood shelves.

Wine Serving & Aging Cabinets

- Black finish, stainless steel door frame
- Removable beechwood shelves
- Multi-function digital controls
- Temperature ranges: Single Zone(S) 41° to 64.4°F, Dual Zone(D) upper zone: 41° to 50°F, lower zone: 50° to 64.4°F
- Thermostatic cabinet
- Fan forced evaporator cooling
- Reversible door
- 24" wide
- 110V
- 1-year parts & labor and 3-year compressor warranty



USF54S



USF168D

	TYPE	DIMENSIONS	BOTTLE SHELVES	CAPACITY†
USF54D	Dual	34½" h x 23½" d	6	46
USF54S	Single	36" h x 24" d	6	57
USF168D	Dual	71½" h x 27" d	14	154
USF168S	Single	71½" h x 27" d	15	165

†Capacities listed for standard bottle size



MW48R



UC48L



MoveWell Adaptive Station with Ultra-Low Profile Refrigerated Base

- Modular design allows instant re-configuration of workstation to improve workflow
- Features an ultra-low profile for tight undercounter spaces
- Constructed with 304 stainless steel
- Maintains precise temperatures
- Digital thermostat on front grille
- Equipped with an automatic defrost cycle and condensate evaporator pan for easy maintenance
- R-290 hydrocarbon refrigerant
- Features 2 refrigerated pull out drawers
- 2-year parts and labor warranty, 5-year compressor warranty

MW48R Adaptive Station, 48" w x 24" d x 32½" h
UC48L Refrigerated Base, 48" w x 24" d x 21" h



Insulated wells and recessed pockets organize garnishes and bitters



KROWNE®

Alchemy Series The Forty-Eight Lab with Refrigerated Base

- Ergonomic mise-en-place stations built for cocktail service
- 32½" working height
- All-stainless steel construction provides superior durability
- Integrated insulated wells and recessed pockets keep garnishes within easy reach
- Refrigerated base with 2 pull out drawers included

AL24-LAB48-R 48" w x 24" d x 41" h

Mise-en-Place meets mixology.

KROWNE®

Alchemy Series Tool Caddy

- Ergonomic 32½" working height reduces bending and back strain
- Premium stainless steel construction and full-length locking handles
- Provides dedicated wet and dry compartments for bar tool organization
- Includes dipperwell faucet and overflow pipe
- Features adjustable bullet feet for precise leveling on uneven floors



AL24-TC12 12" w x 24" x 41" h

Cabinet base design conceals plumbing

TIP

Built for Speed Behind the Bar

From ice bins and blender stations to cocktail units and sinks, underbar equipment keeps bartenders organized and service flowing smoothly. Designed to maximize efficiency in compact spaces, these hardworking essentials help reduce steps, streamline drink prep and keep every shift running at full speed.

Remember the small stuff! Bartender tools and accessories are also essential to every bar. From blenders to mixology tools to bottle displays and garnish organizers, every item works together to deliver speed of service and enhanced customer satisfaction.



Glastender.

Stainless steel fabrication with refined detailing and integrated structural design

Signature Underbar

- The benchmark for professional bar design blending durability, cleanliness and refined style
- Built-to-last with heavy-gauge stainless steel, reinforced structures, fabricated sink bowls and premium components
- Fully welded all-stainless steel fabrication delivers long-term durability
- One-piece seamless work surfaces, backsplashes and front rails with radius corners throughout
- Innovative C-channel backsplashes and interlocking, hemmed edge construction adds superior rigidity
- Flexible customization options available



Choice Underbar

- Designed to match competitor specifications point-for-point, and then exceed them with fully welded construction, stainless steel fabrication and Glastender build standards
- Reinforced durability with welded C-channel stiffeners integrated into the backsplash
- Fabricated 20-gauge sink bowls are approximately 70% thicker than typical industry offerings, improving longevity
- Threaded inserts allow standard-size speed rails to be mounted more easily and more securely than sheet-metal screw methods
- One-piece seamless tops reduce seams to simplify cleaning
- Fully corrugated drainboard work surfaces promote better aeration so glassware dries faster and more efficiently
- Surpasses industry standards and perfect for busy bars and restaurants

Welded stainless steel construction designed for durability and ease of cleaning

Glastender.



Perfect for busy bars and restaurants.

Glastender.

Enhanced ergonomics for bartenders. Elevated engagement for guests

Elevation Underbar

- Elevation blends artistry, performance and enhanced ergonomics with a 36" high work surface that improves bartender's comfort and promotes guest engagement
- Higher work height and optimized layout streamline bartender movements, promoting speed and consistency during service
- Elevated height gives guests an open view to enjoy the craft of cocktail creation
- Choose ice-chilled or refrigerated models featuring pull-out racks for glassware, drawers for bottles and tools and cabinet bases for supplies





Streamlined Bar Solutions

Power your bar with John Boos underbar solutions designed for efficiency, durability and seamless workflow. From compact hand sinks and multi-compartment sinks to drainboards, storage and integrated work surfaces, each component is built from commercial-grade stainless steel to handle high-volume service while keeping everything within reach behind the bar.



Underbar Sink

UBHS-2112

Measuring 12"w x 21"d x 33½"h, this freestanding underbar sink features a 10" x 8" x 6" deep fabricated bowl, 3" high backsplash, faucet holes with 4" centers, soap and towel dispensers, adjustable bullet feet and stainless steel construction.





Constructed from 18-gauge T-304 stainless steel



Includes a sliding lid for easy, one-handed access to ice

BK RESOURCES

Underbar Glass Rinsing Speed Station

- Constructed from 18-gauge T-304 stainless steel for corrosion resistance
- Features a push-down glass rinser
- Includes a dipper well with a chrome-finished faucet and basket
- Integrated backsplash protects walls and simplifies cleanup
- 1-year warranty

UB-SS8 8" w x 18 1/4" d x 15 1/2" h

BK RESOURCES

Mobile Ice Bin

- Mobile design provides convenient ice transport from machine to service area
- Constructed from 18 gauge, T-304 stainless steel for corrosion resistance
- Foamed-in-place insulation
- 3" casters with brakes
- Equipped with a rear drain valve for simple water removal
- Features a removable bottom tray to aid in scooping and cleaning
- 1-year warranty

BK-MIB-2422 22" w x 24" d x 29" h, 117 lbs Capacity

NSF



SWBAR2B48-LR

STEEL WORKS

Underbar Sinks

- Freestanding underbar sinks designed for commercial bars and kitchens
- 18-gauge, 304-series stainless steel for body, legs and cross-bracing
- Features an integrated 3" backsplash and raised marine edges

NSF

	BOWL(S)	DRAINBOARDS	DIMENSIONS
SWBAR1B14	1	-	14 1/2" w x 18 3/4" d x 33" h
SWBAR2B26	2	-	26 1/2" w x 18 3/4" d x 33" h
SWBAR2B36-L	2	11 3/4" Left	36" w x 18 3/4" d x 33" h
SWBAR2B36-R	2	14" Right	36" w x 18 3/4" d x 33" h
SWBAR3B38	3	-	38 1/2" w x 18 3/4" d x 33" h
SWBAR2B48-LR	2	13" Left & Right	48" w x 18 3/4" d x 33" h
SWBAR3B48-L	3	11 3/4" Left	48" w x 18 3/4" d x 33" h
SWBAR3B48-R	3	11 3/4" Right	48" w x 18 3/4" d x 33" h
SWBAR3B60-LR	3	13" Left & Right	60" w x 18 3/4" d x 33" h
SWBAR4B72-LR	4	13" Left & Right	72" w x 18 3/4" d x 33" h



Features a push-down glass rinser

STEEL WORKS

Mixology Station

- Combines a dump sink, glass rinser and dipper well in one unit
- Constructed from 18-gauge 304 stainless steel
- Features a push-down glass rinser with a removable 12" drainboard
- Integrated dipper well features a dedicated faucet
- Equipped with a 4" wall mount faucet for the main sink
- 3" backsplash to protect walls from splashes
- Supported by stainless steel legs with H-shaped bracing and bullet feet
- Includes a 1 1/2" IPS drain with a removable 1 1/2" drain basket
- 11" x 10" x 7" bowl

SW24-MS14 14" w x 24" d x 33" h

NSF



Summit® Edge High-Performance Blender

- Powerful 3½ hp motor blends toughest recipes
- Quiet Shield™ dampens sound for front-of-house use
- 48 oz stackable copolyester container
- Auto Blend™ creates perfect consistency with one touch
- Intuitive touchpad with 6 programmable buttons

HBH855 48 oz



Powerful 3 hp motor handles various blending tasks



Expeditor™ 600 Culinary Blender

- Powerful 3 hp motor handles various blending tasks
- Wave-Action® system thoroughly blends all ingredients
- Variable speed control with low, medium, high and pulse settings
- One-touch chopping, temperature gauge and jar pad sensor
- 64 oz polycarbonate container
- Lifetime warranty on motor drive and blades
- 3-year parts and labor warranty, 2-year ExpressCare Replacement warranty

HBF600R 64 oz

Includes a 14" x 10" sink with a gooseneck faucet



Beverage Table

- All-in-one beverage station
- Heavy-duty 14-gauge T-304 stainless steel top and 18-gauge body
- Features a built-in urn trough with drain to manage drips and spills
- 5" riser backsplash with a standard electric outlet
- Hinged-door cabinet base with 1 adjustable shelf
- 1-year warranty

BEVT-3060R Right Side Sink, 60"w x 30"d x 40½"h



Underbar Hand Sink with Soap & Towel Dispenser

- Features integrated soap and towel dispensers for a complete handwashing station
- Constructed from 18-gauge 304 stainless steel
- Includes a 4" wall mount faucet and 1½" IPS drain with basket
- 10" x 12" x 6" bowl

SWUHS-1812-STD 12½"w x 18¾"d x 33"h



Features 1" adjustable bullet feet





Heavy-Duty Portable Bars

- All stainless steel interior
- Stainless steel workboard and insulated ice bin with drain and shut-off valve
- Bin holds up to 50 lb of ice
- Stainless steel speed rails
- Black mica top and exterior
- Full perimeter bumpers
- 5" swivel casters, 2 with brakes



AMD-5B

Enclosed storage models include hinged stainless steel doors with locks

	SPEED RAILS	STORAGE	DIMENSIONS
AMS-5B	2	Open	62¼" w x 27¼" d x 46¾" h
AMD-5B	2	Enclosed	62¼" w x 28¾" d x 46¾" h
AMS-6B	3	Open	74¾" w x 27¼" d x 46¾" h
AMD-6B	3	Enclosed	74¾" w x 28¾" d x 46¾" h



R-8-B

Rear lower shelf is open for storage



Portable Bars

- Offers a complete workstation for mobile beverage service
- Features a stainless steel work top, speed rails and towel ring(s)
- Includes integrated ice bins complete with drains and shut-off valves
- Rear lower shelf is open for storage
- Heavy-duty 4" casters, 2 with brakes
- Black finish

D-B	50 lb Ice Capacity, 1 Ice Bin, 1 Towel Ring, 61" w x 24½" d x 43¾" h
R-8-B	100 lb Ice Capacity, 2 Ice Bins, 2 Towel Rings, 95¾" w x 24½" d x 47" h

Mobile bar service for any occasion.



Countertop Frozen Drink Machines

- Patented fast freeze technology produces smooth, creamy frozen drinks with rapid recovery
- Low-temperature evaporator and single-piece auger design
- Low-mix indicator light and automatic freeze protection prevent product freeze-ups and downtime
- Backlit merchandising display and a low mix indicator light
- Easy to use mechanical controls
- Gravity fed system
- Single flavor or 2 flavor design

	FLAVORS	SERVINGS PER HOUR	DIMENSIONS
6450-CL	1	110	15" w x 31" d x 30" h
6650-CL	1	165	15" w x 32" d x 33" h
6690-CL	1	240	18" w x 31" d x 34" h
6455-CL	2	190	19" w x 31" d x 32" h
6695-CL	2	320	23" w x 31" d x 39" h



6450-CL



6650-CL

Patented fast freeze technology



6455-CL



6695-CL



Heavy-Duty Equipment Stand

- Heavy-duty stainless steel stand supports all Spaceman countertop soft serve and frozen beverage machines
- Locking cabinet secures mixes and supplies
- 4" casters

CART-550-D 22" w x 32" d x 25" h



Heavy-duty stainless steel



Heavy-Duty Equipment Dolly

- 670 lb capacity easily moves Spaceman countertop beverage machines
- Low-profile 5" height slides under bars and counters
- Stainless steel plate resists rust and wear
- 3" locking casters
- Raised perimeter lip and integrated drain outlet

DLY-476-A 19" w x 26" d x 5" h



Rapid freeze-down and recovery times

Floor Standing Frozen Drink Machine

- Ideal for milkshakes, margaritas, frozen cocktails, smoothies or other frozen drinks
- 2 flavor design serves 480 (10 oz) drinks per hour
- Patented freeze technology and refrigerated hoppers
- Low-temperature evaporator
- Standby/sleep mode and low mix indicator light
- Easy to use mechanical controls
- Gravity fed system
- (2) 7.3 qt freezing cylinders and (2) 20 qt hoppers

6795-CL 25" w x 32" d x 62" h



CRATHCO

CR2501 Series Barrel Freezer

- 10 qt hopper and an 8.4 qt freezing cylinder
- Compact footprint is ideal for countertop placement
- Thick .79" front plate ensures consistent product temperature
- Gravity-fed system with mechanical controls
- 14¹/₁₆"w x 27³/₁₆"d x 30⁵/₁₆"h
- 115V
- Other models available
- 2-year parts warranty, 1-year labor warranty, 5-year compressor warranty



LV563101 9 Gallons per hour



Classic Pro BUBBLER® Dispenser Base & Bowls

- Maintains consistent beverage temperatures between 35° to 41°F
- Agitation system circulates drinks to prevent separation and reduce foam
- Clear polycarbonate bowls with covers
- Stainless steel base panels
- Quick-release components and removable drip trays
- 9" cup clearance
- 9.5 gallon total capacity
- 120V
- 1-year parts and labor warranty



CRATHCO

LV606220 Base, 20¹/₁₆"w x 17¹/₁₆"d x 16¹/₂"h
 LV606307 (2) 4.75 Gallon Bowls, 22³/₁₆"w x 12¹/₁₆"d x 25³/₁₆"h

CRATHCO

I-PRO Frozen Dispenser

- Insulated I-Tank bowls with lockable lids
- Lighted front panel showcases beverages
- Simple mechanical controls ensure product consistency
- Black finish
- 115V
- 17" w x 23" d x 36" h
- 2-year parts warranty, 1-year labor warranty



LV560535 (2) 2.9 Gallon Bowls



Tango XP Super Automatic Espresso Machines

- Super automatic espresso machine designed for high-volume service
- Features the patented TANGO® full-metal brew group with a dedicated motor for consistent tamping
- Offers intuitive control and recipe programming on a 10" touchscreen display
- Available in both 2-step and 1-step configurations with either two or three grinders, 1-step models can produce hot and cold foam products
- Utilizes dual-boiler and Thermalink Technology
- 1.8 L boiler and coffee boiler capacity
- Equipped with high-precision 83 mm flat burr grinders for uniform coffee grounds
- 208-240V



TANGO XP DUO

UNIC

TANGO XP SOLO 1 Dispenser, 15¹/₁₆"w x 25¹/₁₆"d x 31¹/₈"h
 TANGO XP DUO 2 Dispensers, 19¹/₁₆"w x 25¹/₁₆"d x 31¹/₈"h



eurodib

Frozen Drink Machines

- 2.6 gallon bowl(s)
- Simple-to-use dispensing system
- Forced air-cooled compressor
- LED cover
- Stainless steel and plastic construction for chassis and panels provides strength for heavy use
- Disassemble and assemble the tank without tools
- Made in Italy
- 1-year parts & labor warranty, 3-year compressor warranty



OASIS2

Juice Dispensers

- Fully hermetically sealed motor compressor
- Motor with automatic re-starter
- Forced air condenser
- Automatic thermostat
- Stainless steel body with clear polycarbonate bowls and lids
- 3 gallon bowls
- S/S tap and paddle system to avoid froth and oxidation
- 16¹/₂"d x 23¹/₂"h
- 110V (220V also available)
- Made in Italy
- 1-year parts & labor warranty, 3-year compressor warranty



CD2J

	BOWLS	DIMENSIONS
OASIS1	1	10 ³ / ₁₆ "w x 20 ¹ / ₁₆ "d x 33" h
OASIS2	2	16" w x 21" d x 33" h
OASIS3	3	24" w x 21" d x 33" h



	BOWLS	HP	WIDTH
CD1J	1	1/6	8 ¹ / ₄ "
CD2J	2	1/6	15 ¹ / ₄ "
CD3J	3	1/4	23 ¹ / ₄ "
CD4J	4	2 x 1/6	31"



Premia Coffee Brewer

- High-performance brewer automatically grinds, brews and maintains optimal taste and temperature during peak times
- Features an intuitive 4.3" touchscreen for simple recipe customization
- Utilizes SmartWAVE® technology for superior extraction uniformity
- Brews multiple recipes including hot coffee and on-demand cold brew concentrate
- Allows for pre-infusion, pulse brew and digital temperature control for precise flavor extraction
- Large 5.6 gallon tank provides high-volume, back-to-back brewing capacity
- Features Push and Hold dispensing, Brew on Demand mode and liquid auto clean
- 208-240V
- 2-year parts and 1-year labor warranty with a 3-year warranty on the circuit board assembly

61000.0002 3 Hoppers

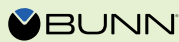

Fast Cup Coffee Brewers

- Delivers fresh-ground, hot-brewed coffee one cup at a time
- Automates the grinding, brewing and grounds management process to reduce labor
- Features a large 10" full-color touchscreen for simple user navigation
- Dispenses hot water through a dedicated line separate from coffee
- 208-240V
- 1-year parts and labor warranty

55400.0111 Standard
 55400.0112 BUNNlink WiFi
 55400.0113 BUNNlink WiFi and Liquid Auto Clean



Serve 2 different frozen beverages from dual 3 gallon hoppers



Ultra NX Frozen Granita Machines

- Features a reversing auger design and beverage monitoring technology for product consistency
- Increases impulse sales with LED lighted merchandisers in the hopper lids
- Supports remote equipment management and data insights via BUNNlink® compatibility
- 120V
- 16 $\frac{1}{2}$ "w x 26 $\frac{1}{2}$ "d x 32 $\frac{1}{2}$ "h
- (2) 3 gal hoppers
- Additional models and options available
- 2-year parts, 1-year labor and 5-year computer warranty



58000.0014



58000.0010 Black



Black & White 4 Superautomatic Espresso Machines

- Super automatic espresso system produces up to 500 cups per day
- Features dual bean hoppers, grinders and double boiler design
- Integrated refrigerator holds up to 10L of milk
- Includes a 10" touchscreen with customizable interface and troubleshooting menus
- Lockout-enabled automatic cleaning process with timed reminders simplifies maintenance
- Adjustable spout accommodates a variety of cup heights
- (2) 3.7 lb bean hopper w/ grinder
- Optional Chocolate Powder System offers rich mochas and delicious hot chocolate beverages
- Other models available
- 1-year parts and labor warranty

59000.0004 Standard, 23 $\frac{3}{4}$ "w x 23 $\frac{3}{4}$ "d x 25 $\frac{1}{2}$ "h
 59000.0008 w/ 4.4 lb Chocolate Powder System, 33 $\frac{1}{2}$ "w x 23 $\frac{3}{4}$ "d x 25 $\frac{1}{2}$ "h



59000.0006



People who serve, products that solve.™

Glo-Ray® Designer Heated Buffet Warmers

- Ideal for holding hot food safely on buffet lines or temporary serving areas
- Features infrared heat above and a thermostatically-controlled hardcoated heated base
- Shatter-resistant incandescent lights enhance food appeal
- Standard with black inset panels
- Accommodates full size or fractional food pans
- Made in USA
- 120V

Sturdy plexi-glass
breath protectors
provide safe serving
environment



	FULL SIZE PAN CAPACITY	DIMENSIONS
GR2BW-24	1	30¼" w x 27" d x 19" h
GR2BW-30	2	36¼" w x 27" d x 22" h
GR2BW-36	2	42¼" w x 27" d x 22" h
GR2BW-42	3	48¼" w x 27" d x 22" h
GR2BW-48	3	54¼" w x 27" d x 22" h



Serve in style.



Electric Sealed Well Steam Table

- Specifically designed for water bath temperature holding
- Features durable 20-gauge stainless steel construction
- Accommodates 3 full size food pans
- Provides independent temperature control for each well
- Delivers 750W of heating power per individual well
- Includes a removable 7" poly cutting board on a stainless steel support shelf
- Open base design with an undershelf offers accessible storage
- 1-year parts warranty

ST-SW-3 3 Wells, 44¾" w x 29½" d x 33¼" h



Each 12" x 20" well is one piece,
deep-drawn, stainless steel
construction



Drop-in Hot Food Wells

- Quick and easy installation in stainless steel countertops
- Infinite control
- For wet or dry operation
- Fully insulated with optional drain
- 23¾" d x 9¾" h
- 208/240V
- 1-year limited parts and labor



MOD-500D 5 Wells, 71½" w, Holds (5) 12" x 20" Pans
MOD-300 3 Wells, 43½" w, Holds (3) 12" x 20" Pans
MOD-200DM 2 Wells, 29½" w, Holds (2) 12" x 20" Pans

Electric Hot Food Tables

- Individually controlled 12" x 20" dry wells maintain precise temperatures for pan up to 7¾" deep
- Stainless steel top, body and 8" support shelf
- 8" removable thermoplastic cutting board
- Infinite control knobs and indicator lights for each well
- Available with an open base or enclosed base
- 120V



OPEN BASE	DIMENSIONS	WELLS	UNDERSHELF	DOORS
HF-2E-120	31½" w x 30%" d x 34%" h	2	1	—
HF-3E-120	47" w x 30%" d x 34%" h	3	1	—
HF-4E-120	62½" w x 30%" d x 34%" h	4	1	—
ENCLOSED BASE	DIMENSIONS	WELLS	UNDERSHELF	DOORS
HF-2E-120-BS	31½" w x 30%" d x 34%" h	2	1	—
HF-2E-120-DR	31½" w x 30%" d x 34%" h	2	1	2 Sliding
HF-3E-120-BS	47" w x 30%" d x 34%" h	3	1	—
HF-3E-120-DR	47" w x 30%" d x 34%" h	3	1	2 Sliding
HF-4E-120-BS	62½" w x 30%" d x 34%" h	4	1	—
HF-4E-120-DR	62½" w x 30%" d x 34%" h	4	1	2 Sliding

More styles and sizes available.

Fiberglass insulation between each well



HF-3E-120

Hot and fresh.

DriTec Hot Food Well Drop-Ins

- Drop-in hot food wells designed for efficient waterless operation
- Wells operate independently with separate thermostatic controls
- Low wattage drop ins operate at 500 watts per well
- One-piece stainless steel top and galvanized steel body offer lasting durability
- High-density polyurethane foam insulation provides superior heat retention
- Designed for a seamless flush-mount installation accommodating 12" x 20" x 6" deep pans
- 208/240V
- 2-year parts and labor warranty

	WIDTH	WELL(S)
N8618-FWH	18"	1
N8633-FWH	33"	2
N8648-FWH	48"	3
N8663-FWH	63"	4
N8678-FWH	78"	5
N8693-FWH	93"	6



N8663-FWH

FlexiWell Combination Drop-Ins

- Independently operated wells for hot, cold or frozen foods
- Features a flush-mounted design with a stainless steel top
- High-density polyurethane foam insulation
- R-290 refrigerant
- Includes a remote control panel with thermostat
- Comes with adapter bars to accommodate 12" x 20" x 6" deep food pans
- Cold: 120V, Hot 208/240V
- 26"d x 26"h

	WIDTH	WELL(S)
N8618-FWP	18"	1
N8633-FWP	33"	2
N8648-FWP	48"	3
N8663-FWP	63"	4
N8678-FWP	78"	5
N8693-FWP	93"	6



N8648-FWP



People who serve, products that solve.™

Drop-In Induction Dry Food Well

- Utilizes dry induction technology for energy-efficient food holding
- Features a durable glass-ceramic well bottom
- Holds full-size or fractional pans, 2½" or 4" deep
- Provides precise temperature control from 150° to 210°F
- Contains two heat zones with two temperature sensors in each zone
- Includes an automatic pan sensor that prevents operation unless a pan is present
- Designed for top or bottom mounting into a countertop
- 208/240V

IWELB-FUL-A 24¼" w x 16" x 9¾" h



People who serve, products that solve.™

Countertop Heated Wells

- Hold hot food hot and fresh in either wet or dry operation
- Features a separate on/off rocker switch and adjustable temperature dial
- Constructed with a stainless steel well and housing
- Includes a pan edge offset to prevent condensation from dripping onto countertops
- Equipped with a dry indicator lamp to alert operators when to add water
- -FUL models can hold (1) full-size pan or (3) ½ size pans
- -43 models can hold (1) full-size pan or (4) ½ size pans
- 120V

HOLD ONLY

HW-FUL 14⁵⁷/₁₀₀" w x 23⁹/₁₀" d x 9¹⁷/₂₀" h

HW-43 14⁵⁷/₁₀₀" w x 30⁹/₁₀" d x 9¹⁷/₂₀" h

COOK AND HOLD

CHW-FUL 14⁵⁷/₁₀₀" w x 23⁹/₁₀" d x 10⁸³/₁₀₀" h

CHW-43 14⁵⁷/₁₀₀" w x 30⁹/₁₀" d x 10⁸³/₁₀₀" h



Drop-In Combination Hot/Cold/Freeze Wells

- Designed for serving stations and buffet lines
- 18 gauge stainless steel
- Thermostatically controlled 12" x 20" food wells
- Each well accommodates hot or cold holding temperatures
- Multi-function electronic control with 3-position switch
- R-290 refrigerant
- Cold wall refrigeration system
- (2) 11³/₈" x 5¹/₄" control panel cutout
- 120V

HCI-4-120 4 Wells, 63" w x 26" d



SHOWN WITH OPTIONAL CASTERS

Electric Individual Sealed Hot Food Table

- Electric hot food table with 12" x 20" x 6½" sealed wells
- 20-gauge stainless steel top with a durable stainless body
- Individual thermostatic controls for each well
- Designed for wet operation with manifold drains and a common gate valve
- Integrated 8" d full-length workboard and a 7" d plate shelf
- Open base design with 6" high adjustable legs
- 120V

3613-120 3 Wells, 48" w x 30" d x 36" h



Hot/Cold/Frozen Modular Drop-Ins

- Delivering the flexibility to switch between hot, cold and frozen holding
- Foamed-in-place polyurethane insulation maintains consistent temperatures and energy efficiency
- Designed to hold full-size and fractional food pans up to 6" deep
- ¼ hp

Rugged 18 gauge, 300-series stainless steel top and wells

FC-HCF-02208-AD



FC-HCF-03208-AD

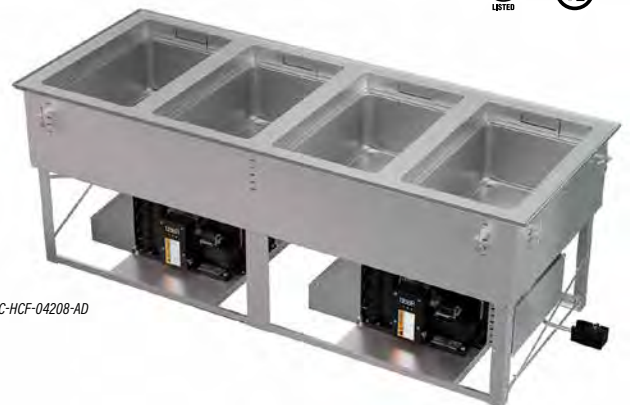

FC-HCF-04208-AD



STANDARD	WELL(S)	DIMENSIONS	VOLTAGE
FC-HCF-02120	2	33¾" w x 26" d x 24¾" h	120V
FC-HCF-02208	2	33¾" w x 26" d x 24¾" h	120V/208-240V
FC-HCF-03120	3	49¾" w x 26" d x 24¾" h	120V
FC-HCF-03208	3	49¾" w x 26" d x 24¾" h	120V/208-240V
FC-HCF-04208	4	65¾" w x 26" d x 24¾" h	120V/208-240V
W/AUTO DRAIN			
FC-HCF-01120-AD	1	18" w x 26" d x 24¾" h	120V
FC-HCF-01208-AD	1	18" w x 26" d x 24¾" h	120V/208-240V
FC-HCF-02120-AD	2	33¾" w x 26" d x 24¾" h	120V
FC-HCF-02208-AD	2	33¾" w x 26" d x 24¾" h	120V/208-240V
FC-HCF-03120-AD	3	49¾" w x 26" d x 24¾" h	120V
FC-HCF-03208-AD	3	49¾" w x 26" d x 24¾" h	120V/208-240V
FC-HCF-04208-AD	4	65¾" w x 26" d x 24¾" h	208/240V
W/FLAT FLANGE			
FC-HCF-02120-FF	2	33¾" w x 26" d x 24¾" h	120V
FC-HCF-02208-FF	2	33¾" w x 26" d x 24¾" h	120V/208-240V
FC-HCF-03120-FF	3	49¾" w x 26" d x 24¾" h	120V
FC-HCF-03208-FF	3	49¾" w x 26" d x 24¾" h	120V/208-240V
FC-HCF-04208-FF	4	65¾" w x 26" d x 24¾" h	208/240V
W/AUTO DRAIN & FLAT FLANGE			
FC-HCF-01120-AD-FF	1	18" w x 26" d x 24¾" h	120V
FC-HCF-01208-AD-FF	1	18" w x 26" d x 24¾" h	120V/208-240V
FC-HCF-02120-AD-FF	2	33¾" w x 26" d x 24¾" h	120V
FC-HCF-02208-AD-FF	2	33¾" w x 26" d x 24¾" h	120V/208-240V
FC-HCF-03120-AD-FF	3	49¾" w x 26" d x 24¾" h	120V
FC-HCF-03208-AD-FF	3	49¾" w x 26" d x 24¾" h	120V/208-240V
FC-HCF-04208-AD-FF	4	65¾" w x 26" d x 24¾" h	208/240V

Modular Drop-In Dry Hot Wells

- Maintains optimum serving temperatures with an efficient waterless dry heat design
- 300-Series stainless steel construction
- High-density glass fiber insulation on all sides maximizes energy efficiency
- Includes a remote stainless steel panel with infinite controls
- Accommodates standard full size or fractional food pans up to 6" deep
- Mounting clips adjust for easy installation in countertops up to 3" thick
- 1-year limited warranty

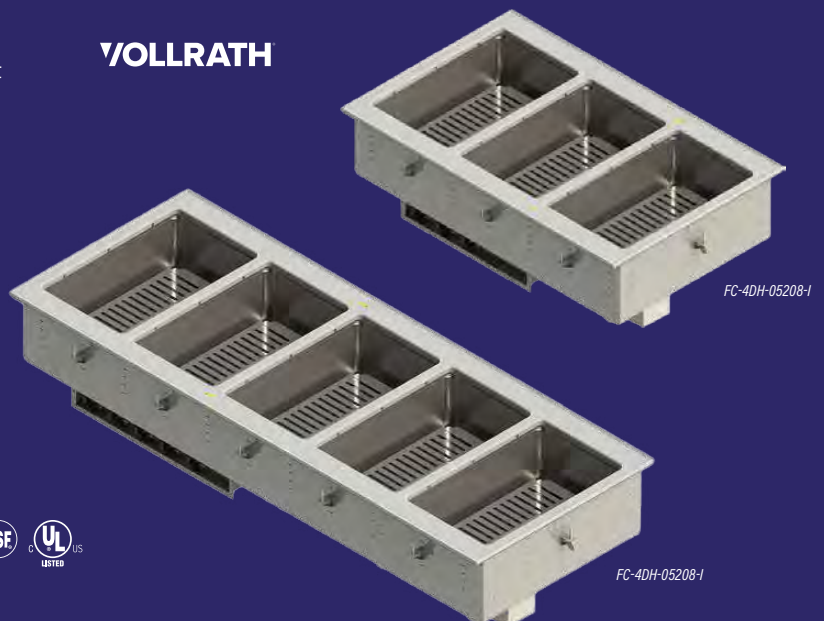

FC-4DH-05208-I

FC-4DH-05208-I





ServeWell® Hot Food Tables

- One piece thermoset well cannot pit or rust
- Dome elements transfer energy directly into the water bath
- Equipped with standard 480W, 700W or 800W elements
- Each well is equipped with a brass drain valve
- Plate shelf and 8" wide cutting board on operator's side
- Made in USA
- 32"d x 34"h

Stainless steel construction includes legs and undershelf

480W	WELLS	WIDTH	VOLTAGE
38002	2	32"	120V
38003	3	46"	120V
38004	4	61¼"	120V
38005	5	76"	120V
700W			
38102	2	32"	120V
38103	3	46"	120V
38104	4	61¼"	120V
38105	5	76"	120V
600-800W			
38116	2	32"	208-240V
38117	3	46"	208-240V
38118	4	61¼"	208-240V
38119	5	76"	208-240V

VOLLRATH



VOLLRATH

ServeWell® SL Hot Food Tables

- Streamlined ServeWell® SL design saves valuable floor space in serving lines
- Features a 20-gauge stainless steel top with 16-gauge stainless steel legs
- Dome heating elements use up to 25% less energy by concentrating heat in the wells
- Self-insulating thermoset fiber-reinforced resin wells maximize energy efficiency and will not rust or pit
- Thermostatic controls automatically adjust to food volume for precise temperature holding
- Includes a low-water indicator light and individual brass drain valves for each well
- 29½"d x 34"h

480W	WELLS	WIDTH	VOLTAGE
38203	3	46"	120V
38204	4	61¼"	120V
38205	5	76"	120V
700W			
38213	3	46"	120V
38214	4	61¼"	120V
38215	5	76"	120V
600-800W			
38217	3	46"	208/240V
38218	4	61¼"	208/240V
38219	5	76"	208/240V



Compact and efficient.

2-Series Hot Food Stations

- The perfect solution for hot food serving
- Upgraded thermoset wells with high efficiency 480 watt in-water heating elements
- Easy access, fully enclosed clear acrylic breath guard, 12" clearance
- Seamless one-piece 20-gauge, 300 series stainless steel work surface
- Optional storage with doors
- High density insulation
- Scratch resistant vinyl clad steel exterior in four colors
- Spillage pans required, sold separately
- Made in USA
- 24"d x 35"h



ENCLOSED BASE	WELLS	WIDTH
38707	3	46"
38710	4	60"
SOLID W/LIGHTS		
3870746	3	46"
3871060	4	60"
OPEN STORAGE BASE		
38708	3	46"
38711	4	60"
OPEN W/LIGHTS		
3870846	3	46"
3871160	4	60"
STORAGE BASE W/ DOORS		
38709	3	46"
3871260	4	60"
STORAGE W/DOOR & LIGHTS		
3870946	3	46"
38712	4	60"



VOLLRATH

2-Series Front of House Cold Food Stations

- Display and serve a variety of cold-food items
- Scratch-resistant black vinyl-clad carbon steel exterior
- Easy access, fully enclosed clear acrylic breath guard - 12" clearance
- Seamless one-piece 20 gauge, 300 series stainless steel work surface
- Optional storage with doors
- Non-refrigerated 6" deep well
- Foamed-in-place polyurethane foam insulation
- 1" drain makes cleanup easy
- 120V
- 24"d x 35"h



ENCLOSED BASE	WELLS	WIDTH
38713	3	46"
38716	4	60"
SOLID W/LIGHTS		
3871346	3	46"
3871660	4	60"
OPEN STORAGE BASE		
38714	3	46"
38717	4	60"
OPEN W/LIGHTS		
3871446	3	46"
3871760	4	60"
STORAGE BASE W/ DOORS		
38715	3	46"
38718	4	60"
STORAGE W/DOOR & LIGHTS		
3871546	3	46"
3871860	4	60"



VOLLRATH

BUFFET

FlexiWell - ShelleySteel Mobile Combination Serving Counters

- Features a 14-gauge stainless steel top and 18-gauge stainless steel body
- Utilizes eco-friendly R-290 GreenGenius refrigerant
- High-density polyurethane foam insulation provides consistent temperature retention
- 5" non-marking swivel casters with brakes
- Cold: 120V, Hot 208/240V
- 30"d x 36"h
- 2-year parts and labor, 7-year compressor warranty

Delfield



	WIDTH	WELL(S)
SFW-1-NU	28"	1
SFW-2-NU	42"	2
SFW-3-NU	56"	3
SFW-4-NU	72"	4
SFW-5-NU	86"	5
SFW-6-NU	102"	6



SFW-3-NU SHOWN WITH OPTIONAL FOODSHIELD

Independently controlled wells switch between hot, cold or freeze modes

DriTec - ShelleySteel Mobile Dry Hot Serving Counters

- Features a heavy-duty 14-gauge stainless steel top
- Independently controlled wells operate at 500 watts per well
- 5" swivel casters with brakes
- 208/240V
- 30"d x 36"h
- 2-year parts and labor warranty

Delfield



	WIDTH	WELL(S)
SFWH-1-NU	28"	1
SFWH-2-NU	42"	2
SFWH-3-NU	56"	3
SFWH-4-NU	72"	4
SFWH-5-NU	86"	5
SFWH-6-NU	102"	6

Mobile dry-heat serving counters for flexible hot food holding



HBCW8-AS-UC



HBCN8-AS-T

Metro HotBlox Holding Cabinets

- Insulated cabinets provide versatile holding options that adapt to your unique space and menu needs
- Hybrid convection-radiant heating technology allows the flexibility to hold moist or crispy food within the same cabinet
- Available with digital or analog controls
- 8 pan capacity
- Models available with clear or solid doors, additional sizes and styles available

HBCW8-AS-UC Undercounter, Analog, 25"w x 30 $\frac{3}{8}$ "d x 31 $\frac{1}{2}$ "h
 HBCN8-AS-T $\frac{1}{2}$ Height Transport, Analog, 24"w x 29 $\frac{1}{2}$ "d x 35 $\frac{1}{2}$ "h



Buffet Display Table

- Refrigerated buffet table with 3 solid doors
- Maintains safe product temperatures between 33° and 39°F
- Stainless steel exterior with a stainless steel interior floor
- Features a side-mount compressor with front air intake
- Utilizes eco-friendly R-290 hydrocarbon refrigerant
- External digital display provides at-a-glance temperature monitoring
- Includes 3 PE coated wire shelves and accommodates (15) $\frac{1}{2}$ size condiment pans (included)
- 4" dia swivel casters, front locking
- 2-year parts and labor, 5-year compressor warranty

JBT-72-N 70 $\frac{1}{2}$ "w x 27 $\frac{1}{2}$ "d x 29"h



Turbo air REFRIGERATOR MANUFACTURER



Fresh food on full display.



PCU1000PP615



PCU800CC615

PCU2000HH615



Pro Cart Ultra® Pan Carriers

- Hold and transport hot and cold foods in a single cart
- Energy efficient—save up to 30% on energy cost vs. other electric cabinets
- Hot Module: adjustable temperature from 140° to 185°F, heat up to 165°F in 15 minutes
- Cold Module: adjustable temperature from 32.5° to 40°F without a compressor
- Available in five sizes to hold 8, 10, 16 or 20 4" deep GN 1/1 food pans
- Hot and Cold sections are 110V
- Charcoal Gray

8 PAN CAPACITY, 21½" w x 34" d x 59½" h

- PCU800CC615 Cold/Cold
- PCU800HC615 Hold/Cold
- PCU800HH615 Hot/Hot
- PCU800HP615 Hot/Passive
- PCU800PP615 Passive/Passive

10 PAN CAPACITY, 22" w x 34" d x 67" h

- PCU1000CC615 Cold/Cold
- PCU1000CP615 Cold/Passive
- PCU1000HC615 Hot/Cold
- PCU1000HH615 Hot/Hot
- PCU1000PP615 Passive/Passive

10 PAN CAPACITY, 30" w x 38" d x 39½" h

- PCUL1000H615 Hot
- PCUL1000C615 Active Cold

16 PAN CAPACITY, 30" w x 38" d x 59" h

- PCU1600CC615 Cold/Cold
- PCU1600HH615 Hot/Hot
- PCU1600PP615 Passive/Passive

20 PAN CAPACITY, 30" w x 38" d x 68" h

- PCU2000CC615 Cold/Cold
- PCU2000HC615 Hot/Cold
- PCU2000HH615 Hot/Hot
- PCU2000HP615 Hot/Passive
- PCU2000PP615 Passive/Passive



Mobile Serving Cart with Cabinet Base

- Stainless steel construction
- Includes an integrated push/pull handle and insulated ice bin cooler
- Equipped with 2 slanted overshelves for organized display and quick access
- Provides secure storage with a locking cabinet base and 2 hinged doors
- (4) 5" swivel casters, w/ brakes

MSC-3048 58" w x 30" d x 68½" h

Heated Banquet Cabinet

- Features a bottom mounted convection heating module and blower motor
- Type 304 stainless steel exterior and interior
- High-density 1" fiberglass insulation
- Includes dial thermostatic controls and an external thermometer
- Two-door design with hands-free kick-latches accommodates plates up to 11¾" dia and full size sheet pans
- 6" polyurethane casters
- Holds (200) Stacked Plates, (200) Covered Carriers and (160) Open Carriers



MBQ-200D 4 Shelves, 67¼" w x 33¾" d x 75" h





Modular Breakfast Carts

- Choose your style, choose your options to fit a wide variety of budgets
- Designed for convenient merchandising of breakfast and snack items
- Stainless steel construction
- 5" swivel casters, 2 with brakes for easy mobility
- Choose from flat, angled or eutectic cut-out shelves
- Optional overhead sign panel with graphic
- Integrated magnetic price holders for clear and easy labeling
- Made in USA

	DIMENSIONS	SHELVES	BASKETS PER SHELF
172621	42½"l x 22¼" w x 39" h	2	3
172622	55½"l x 22¼" w x 39" h	2	4
172619	42½"l x 22¼" w x 57" h	3	3
172620	55½"l x 22¼" w x 57" h	3	4



300 series stainless steel construction



Classic Carters™ Series Banquet Carts

- Exceptionally even heat distribution with fast heat-up and recovery
- Features include fully removable blower heater, lapped corners for easy cleaning and welded unibody assembly for exceptionally long life
- Full perimeter bumper
- Accommodates plates up to 10½"
- 6" casters, two braking



BB100

	DIMENSIONS	COVERED PLATE CAPACITY
BB90	31" w x 42" d x 63½" h	90
BB100	41½" w x 34" d x 69½" h	96
BB200D	61" w x 30½" d x 71½" h	200



Utility & Bussing Cart

- 350 lb distributed weight capacity
- (3) 18" x 27" reinforced shelves
- 18-gauge, all-welded stainless steel construction
- 5" non-marking casters provide smooth, quiet mobility
- Corner bumpers guard walls and equipment from impact
- Custom sizes available
- Optional accessories available to reinforce top and middle shelves for heavy-duty, increased weight capacity and durability: items /RTS and /RMS
- Made in USA

US1827-3 33½" w x 19½" d x 35" h



Standard Ladderback Metal Chairs & Barstools

- Classic ladderback seating
- 100% welded construction featuring a 1.2 mm tubular steel frame with premium powder coat finish
- 2 leg supports on chairs, 3 on barstools
- Supports up to 500 lb
- Non-marring glides
- Available with a wood or vinyl seat
- Multiple colors available

CM-234
Chair, 15 $\frac{1}{8}$ "w x 15 $\frac{7}{8}$ "d x 32 $\frac{1}{4}$ "h
BM-234
Barstool, 15 $\frac{1}{8}$ "w x 15 $\frac{7}{8}$ "d x 42 $\frac{1}{4}$ "h
SL2301S
Swivel Barstool, 16" w x 15 $\frac{7}{8}$ "d x 44 $\frac{1}{8}$ "h



BM-234-RED

SL2301S-BLK

CM-234-WINE

Indoor commercial seating with a supportive bucket design



CM-10501-U-BLK-LM

BM-10501-IMP-DW-ESP

Amata Seating

- 1.2 mm tubular metal frame
- Commercial-grade vinyl bucket seat
- Non-marring poly glides
- Multiple c - 1.2 mm tubular metal frame
- Commercial-grade vinyl bucket seat
- Non-marring poly glides
- Multiple colors and finishes available

CM-10501 Chair, Multiple Sizes Available
BM-10501 Barstool, Multiple Sizes Available

Timber 2.0 Series Metal Frame Seating



- Pairs a distressed solid wood seat and back with a fully welded steel frame
- Heavy-duty 1.2 mm steel construction with a durable black sandtex powder-coat finish
- Black stain (-BLK), clear coat (-NT) and timber stain (-TI) finishes available

CM-W702-2 Chair, 16 $\frac{1}{2}$ "w x 18 $\frac{7}{8}$ "d x 31"h
BM-W702-2 Barstool, 16 $\frac{1}{2}$ "w x 18 $\frac{7}{8}$ "d x 44 $\frac{1}{4}$ "h



CM-W702-TI



Spartan Casino Swivel Barstool

- Iron Gray powder coated frame
- 100% welded XL heavy-duty tubular steel frame with matching footring
- Non-marring glides
- Heavy-duty swivel attached to frame
- Quality fabric-backed, commercial grade vinyl bucket

BM-10660 Barstool, 18 $\frac{3}{4}$ "w x 18 $\frac{3}{4}$ "d x 48 $\frac{1}{2}$ "h



Ladderback Chairs & Barstools

- Features a fully welded frame built with 1 $\frac{1}{4}$ " steel tubing
- Classic ladderback design for versatile commercial seating
- Engineered to support a 500 lb
- Equipped with non-marring glides to protect floor surfaces
- Plain or brass weld options available

PLAIN WELD
SL135C-P2 Chair, 15" w x 15 $\frac{1}{8}$ " d x 32 $\frac{1}{4}$ " h
SL135C-1-P2 Barstool, 15 $\frac{1}{8}$ " w x 15 $\frac{7}{8}$ " d x 42 $\frac{1}{4}$ " h
SL135C1-S-P Swivel Barstool, 16" w x 15 $\frac{7}{8}$ " d x 46 $\frac{1}{8}$ " h

BRASS WELD
SL135C-B2 Chair, 15" w x 15 $\frac{1}{8}$ " d x 32 $\frac{1}{4}$ " h
SL135C-1-B2 Barstool, 15 $\frac{1}{8}$ " w x 15 $\frac{7}{8}$ " d x 42 $\frac{1}{4}$ " h
SL135C1-S-B Swivel Barstool, 16" w x 15 $\frac{7}{8}$ " d x 46 $\frac{1}{8}$ " h



SL135C-P2-WB

SL135C-1-P2-BLK

SL135C1-S-B-BLK

Ambrose Vinyl/Upholstered Booths

- Features a fully sculpted, springless foam seat that is removable and reversible
- Finished ends on both sides allow for versatile and reconfigurable arrangements
- Bolted-on seat backs offer enhanced structural strength

AM-4842-SGL-BLK RTS Single, 48" w x 23 $\frac{1}{2}$ " d x 42" h
AM-4842-DBL-BLK RTS Double, 48" w x 43" d x 42" h



AM-4842-SGL-BLK RTS

AM-4842-DBL-BLK RTS

Sit back in style.



Elbow Series Faux Wood Seating

- Features an elbow back style with a faux wood grain finish
- Metal frame construction provides commercial-grade durability
- Black vinyl seat offers comfort and simplifies cleaning
- Includes non-marring glides to protect floor surfaces
- Driftwood wood grain (-DW-BLK) and faux natural clear coat (-NT-BLK) finishes available

CW-6063 Chair, 21" w x 17" d x 29 7/8" h
BM-6063 Barstool, 21" w x 18 1/2" d x 41" h



Verticalback Metal Frame Seating

- Constructed of heavy 18 gauge, 1 1/4" steel tubing and powder coated in premium Black wrinkle finish
- Available with wood or vinyl seat
- Multiple colors available
- Includes durable, non marring plastic floor glides

SL2090 Chair, 15 5/8" w x 15 1/8" d x 32 1/4" h
SL2090-1 Barstool, 15 5/8" w x 15 1/8" d x 42 1/4" h
SL2090S Swivel Barstool, 16" w x 15 5/8" d x 44 1/8" h



Features an easy-to-clean vinyl seat

Aurora Series Wood Frame Seating

- Built with a solid wood frame and back
- Finished with a natural clear coat to protect the wood
- Includes non-marring glides to safeguard floor surfaces

CW-0439-NT-BLK Chair, 20 1/2" w x 19" d x 34 1/4" h
BW-0439-NT-BLK Barstool, 20 1/2" w x 19" d x 41 1/8" h



BW-0439-NT-BLK

Windowpane Metal Frame Seating

- Constructed of heavy 18 gauge, 1 1/4" steel tubing and powder coated in premium Black wrinkle finish
- Available with wood or vinyl seat
- Multiple colors available
- Includes durable, non marring plastic floor glides

SL2163 Chair, 15 7/8" w x 15 1/8" d x 32 1/4" h
SL2163-1 Barstool, 15 7/8" w x 15 1/8" d x 42 1/4" h
SL2163S Swivel Barstool, 16" w x 15 7/8" d x 44 1/8" h



Harbor Series Wood Frame Seating

- Features a durable wood frame for commercial dining spaces
- Upholstered with easy-to-clean black vinyl on back and seat
- Equipped with non-marring glides to protect floor surfaces
- Arrives fully assembled and ready for immediate use

CW-0234-NT-BLK Chair, 16 1/2" w x 18 3/8" d x 31" h
BW-0234-NT-BLK Barstool, 16 1/2" w x 18 3/8" d x 44 1/4" h



BW-0234-NT-BLK



SL2163-WB

SL2163-1-BLK

SL2163S-WB



Urban Series Table Tops

- Laminate table tops engineered for commercial indoor dining
- Features thermally fused laminate on both sides for a balanced, warp-resistant surface
- Thick 2" profile with coordinating PVC edge for impact and chip resistance
- Available in multiple colors

UB Available Sizes: 24" x 24", 24" x 30", 30" x 30", 30" x 42", 30" x 48", 30" x 60", 30" x 72", 36" x 36", 24" dia, 30" dia & 36" dia



Woodland Series Table Tops

- Constructed with a 1" red oak faced core
- Features a 1 1/2" solid wood dropped edge for a substantial profile
- Made in USA
- Stocked in Dark Walnut and Clear Coat - available MTO in multiple colors

WDL Available Sizes: 24" x 24", 24" x 30", 30" x 30", 30" x 42", 30" x 48", 30" x 60", 30" x 72" & 36" x 36"



Designed with a smooth, eased edge profile

COMPCOR Quick Ship Indoor/Outdoor Table Tops

- Compact HPL (high-pressure laminate) construction
- Thin 1/2" profile with a finished black core edge
- Pre-machined for easy and secure attachment to a variety of table bases
- Available in multiple colors and sizes, with or without a pre-drilled umbrella hole
- Optional 2" pre-drilled hole easily accommodates patio umbrellas
- Available in multiple colors

CC Available Sizes: 24" x 30", 30" x 30", 36" x 36", 30" x 48", 30" x 72", 30" dia, 36" dia & 48" dia



Mix and match with style.

Black Stamped Steel Table Bases

- Stamped steel construction
- Black Sandtex finish offers excellent wear resistance
- Features an oversized, welded top spider for superior table top support
- Available with 3" or 4" diameter column in standard (-STD), counter (-CTR) and bar (-BAR) heights
- Includes non-marring adjustable ply levers for stability on uneven floors

B** Cross Base, Available Sizes: 22" x 22", 22" x 30", 30" x 30", 36" x 36" & 40" x 40"

B5** T Base, Available Sizes: 5" x 22" & 5" x 30"

BDISC** Disc Base, Available Sizes: 18" dia, 22" dia & 30" dia
**Replace with Base Measurement(s)

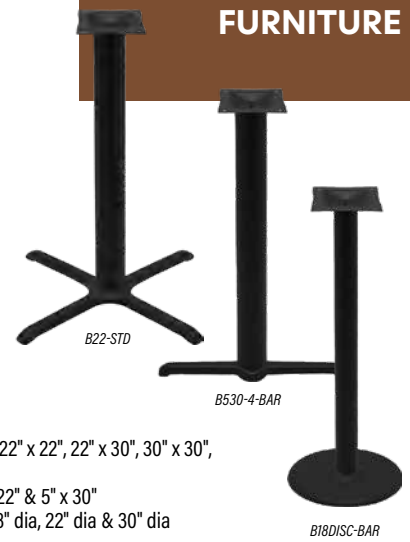

DURAFINISH Outdoor Table Bases

- Built for outdoor stability with a protective DURAFINISH powder coat
- Includes adjustable non-marring levelers for stability on uneven ground
- Reinforced with a welded spider and anchor plate for lasting support
- 1 1/4" umbrella hole in spider
- Inner steel tube and tension bolt located underneath spider to stabilize umbrellas in outdoor conditions
- Available with 3" or 4" diameter column in standard (-STD) and bar (-BAR) heights

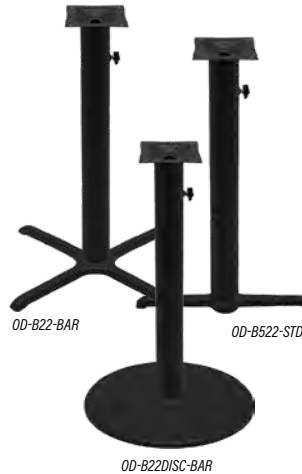

OD-B** Cross Base, Available Sizes: 22" x 22", 22" x 30", 30" x 30" & 36" x 36"

OD-B5** T Base, 5" x 22"

OD-BDISC** Disc base, Available Sizes: 18" dia, 22" dia & 30" dia

**Replace with Base Measurement(s)



NOROCK Self-Stabilizing Table Bases

- Zinc-coated steel construction resists corrosion for indoor or outdoor use
- Sandstone black finish
- Available in standard (-STD) and bar (-BAR) height with 3" diameter columns

BNR** Cross Base, Available Sizes: 22" x 22", 22" x 30", 30" x 30" & 36" x 36"

B5NR** Cross Base, Available Sizes: 5" x 22"

BDISCNR** Disc Base, Available Sizes: 17" dia & 21" dia
**Replace with Base Measurement(s)

Self-stabilizing mechanical base instantly



Chester Dining Chair

- Solid wood dining chairs with a curved spindle backrest
- Built with mortise and tenon joinery for lasting durability
- Features a padded vinyl seat for guest comfort
- Supports a static weight capacity of 500 lb
- Arrives fully assembled with fixed floor protector glides
- Black



XU-DG-W0359-BLK-GG

19¾" w x 19¾" d x 30¾" h



Verona Dining Chair

- Features a solid beechwood frame for commercial dining use
- Mortise and tenon construction
- Supports a 500 lb static weight capacity
- Designed with a curved oval backrest for guest comfort
- Arrives fully assembled with fixed protector glides
- Antique copper finish

XU-CH10367-3-ANTCPR-GG
17¼" w x 20¾" d x 33¼" h

Seating made simple.



Dover Indoor-Outdoor Stacking Patio Chair

- Designed for commercial indoor and outdoor patio seating
- Constructed from high-grade, UV-resistant resin for all-weather use
- Features a contoured seat and curved backrest for guest comfort
- Stacks up to 6 chairs high for convenient, space-saving storage
- Arrives fully assembled and ready for immediate deployment
- Black

DHF-340-APP-BLK-GG

19" w x 19½" d x 31" h



Bridgeport Indoor-Outdoor Stacking Patio Chair

- Commercial-grade seating for all-weather indoor and outdoor use
- Constructed from high-grade resin for UV and fade resistance
- Features a slatted backrest and a contoured seat for guest comfort
- Stacks up to 6 chairs high for efficient storage
- Arrives fully assembled for immediate deployment
- Black

DHF-317-APP-BLK-GG

19¾" w x 20¾" d x 31¾" h



Marseille Indoor/Outdoor Commercial Bistro Stacking Chair



- Commercial-grade bistro chairs for indoor or outdoor use
- Rust-proof aluminum frame with a bamboo print finish
- Features a fade-resistant black Textilene seat and back
- Supports a static weight capacity up to 400 lb
- Stacks up to 5 chairs high for convenient storage

SDA-ADS642108-BK-NAT-GG

22¾" w x 22¼" d x 33" h

TIP

Build the Perfect Table

Once you have chosen the perfect style table for your venue, follow these tips for pairing the best base for your table top.

- Round Tops should be paired with a single central pedestal
- Square & Rectangular Tops require a cross base (X-prong) or disc base
- Long Rectangular Tops require dual pedestals, T-bases or 2 X-prong bases

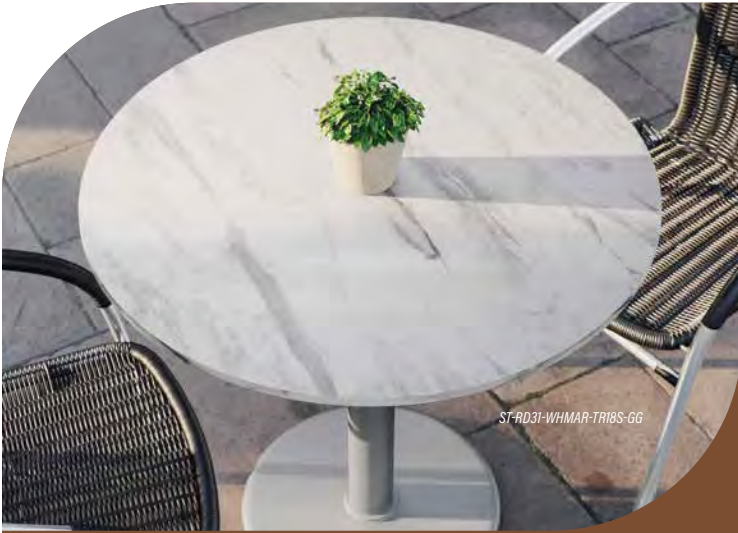

ST-RD31-WHMAR-TR18S-GG



SDA-T2222-GG



XU-DG-TB002-OUT-BLK-GG



XU-T3030-SLV-GG



Indoor/Outdoor Table Bases

- Establish a sturdy foundation for indoor or outdoor dining tables with these cast iron table bases
- Chambery has a black, all-weather finish that resist UV damage
- Palis is powder-coated steel construction with a rust-resistant finish
- Beverly is cast iron with a silver powder-coated finish provides corrosion resistance for all-weather use

SDA-T2222-GG

Chambery, X-Style, For 30" Round/Square Table Tops, 22³/₄"w x 22³/₄"d x 28¹/₄"h, Includes Adjustable Slides

XU-DG-TB002-OUT-BLK-GG

Palis, Double Column, For 30" x 48" Rectangular Table Tops, 27"w x 15"d x 30¹/₂"h

XU-T3030-SLV-GG

Beverly, 30" w x 30"d x 31"h, Cast Iron, Silver

Solid support,
modern style.



TopGuard Outdoor Table & Table Tops

- Enhance indoor and outdoor dining areas with these commercial-grade tabletops. The High Pressure Laminate (HPL) construction offers all-weather performance with resistance to heat, moisture, UV damage, scratches and stains
- Seamless (HPL) wrapped edge
- Solid hardboard core
- Table features an 18" dia cast iron table base

ST-RD31-WHMAR-TR18S-GG

Round Table, 31¹/₂" dia x 29¹/₂"h, White Faux Marble Top w/Silver Base

ST-RT30X48INB-1-M-3A-W-BR-GG

Rectangular Table Top, 48"w x 30"d, Dark Brown

ST-SQ918B-1-M-3A-CM-GY-GG

Square Table Top, 36"w x 36"d, Faux Concrete



Bennett Solid Wood Tables

- Commercial grade, 1¹/₂" thick solid wood table tops
- Table features a rust-resistant black cast iron base
- Includes adjustable floor glides for a wobble-free dining surface
- Supports a static weight capacity of up to 300 lb

GSF-RD30-DKBRN-TR18-GG

Table & Base, 30" dia x 29¹/₂"h, Dark Brown Wood w/Cast Iron Base

GSF-003-24X30-NAT-GG

Table Top, 24"w x 30"d, Natural Wood

GSF-003-24X30-NAT-GG



Astoria Seating

- Technopolymer construction
- Commercial-grade durability for indoor or outdoor dining
- Lightweight and stackable for efficient handling and storage
- UV, weather and saline air resistant
- Multiple colors available
- 3-year warranty

UT945056 Armchair, Navy
 UT944414 Side Chair, Red



Contoured seat and back



UT945056

UT944414

Comfortable outdoor dining.



UT115002

UT110181

Cannes Seating

- Fiberglass-reinforced resin construction
- UV-resistant and weather-resistant for outdoor settings
- Lightweight and stackable for easy handling and storage
- Contoured design
- Suitable for indoor and outdoor use in restaurants, cafes and other hospitality settings
- Made in USA
- Multiple colors available
- 3-year warranty

UT115002 Armchair, Charcoal
 UT110181 Side Chair, French Taupe

Windmaster Umbrellas

- Built to sustain the unpredictable abuses of the wind
- Replaceable fiberglass ribs
- Extra large vent to release the pressure
- Colorfast, easy to maintain Recacril® Marine Grade solution-dyed acrylic fabric
- Bases and umbrellas sold separately
- Several styles and colors of umbrella bases available
- Multiple colors available
- 3-year limited fade warranty on fabric

98301931 7½', Orange
 98389731 7½', Pacific Blue



1 1/2" diameter aluminum pole

UMBRELLA BASES SOLD SEPARATELY

Aquaba Resin Pedestal Tables

- Weather-resistant resin construction
- Four-prong pedestal base with adjustable levelers for stability on uneven surfaces
- Integrated umbrella hole with cap
- UV-resistant and impervious to salt air and chlorine
- Zinc tabletop with charcoal legs
- Made in the USA

US744002 Square, 32" x 32"
US921002 Round, 38" dia
US480902 Round, 48" dia



Slatted tabletop design prevents water pooling and speeds up drying time



Sigma Dining Tables

- Aluminum construction provides rustproof and UV-resistant performance in outdoor settings
- Adjustable leg levelers create a stable dining surface on uneven patios
- Integrated umbrella hole with cap allows for optional patron shading
- Volcanic Black

US928288 Square, 34" x 34"
US929288 Rectangular, 48" x 34"
US932288 Rectangular, 69" x 39"

Westport Bench

- Perfect balance of weight to resist strong winds but maintain ease of handling
- ASTM tested to hold 900+ lb in weight for superior strength and durability
- French Taupe
- Made in the USA
- 3-year warranty

Folds for optimal storage and easy transportation



US449181 58 $\frac{3}{4}$ "w x 22"d x 30"h



TIP

**Patio Dining Support
That Stays Out of Sight**

No one likes a wobbly table or a shaky chair, especially when dining out. For furniture that sits on uneven surfaces or has an uneven base, using small, graduated wedges or glides is an effective way to fill gaps and stop the wobble. Simply slide the wedge or glide under the base and adjust as necessary until the piece is stationary, then you're ready to seat the next guest. These simple-to-use tools eliminate the need for temporary fixes and provide stability and comfort for your guests.



INDEX

Use this index to quickly find the product you are looking for.

A

Air Curtain19
 Airport Bin143

B

Back Bar Cooler.....152, 153
 Back Bar Tool Caddy156
 Banquet Cart171
 Bar, Portable.....161
 Barstool173, 174
 Beer Cooler.....154
 Belgian Waffle Maker94, 95
 Bench.....179
 Beverage Table.....160
 Blast Chiller.....20, 21
 Blender.....125, 160
 Booth.....173
 Braising Pan68
 Breakfast Cart172
 Buffet Display Table.....170
 Bun Grill Toaster96
 Bus Cart172
 Bus/Storage Tub.....143

C

Can Storage Rack.....129
 Cantilever Shelving.....131
 Chair173, 174, 176, 178
 Charbroiler.....89, 90
 Cheese Melter.....51, 52
 Chef Base.....32-34
 Chef Table.....127
 Chip Warmer.....116
 Cocktail Prep Cooler.....154
 Coffee Brewer.....164
 Cold Food Bar169, 170
 Combi Oven54-56, 106-108
 Combi Oven Liner106
 Compartment Sink.....137, 139, 142
 Compartment Sink Power Wash.....138, 141
 Convection Oven55, 57-60, 109
 Convection Steamer71
 Conveyor Oven.....63, 100, 102, 103
 Conveyor System, Soiled Tray138
 Conveyor Toaster95, 96
 Cook & Hold Oven.....64
 Counterline Stand.....87
 Crepe Maker93
 Crisper Station97

Cube Ice Machine42-44, 46-48
 Cutter/Mixer/Emulsifier123

D

Dicer120
 Dish Cabinet.....144
 Dish Machine.....145-151
 Dishtable.....140, 142
 Dishwasher145-151
 Display Refrigerator8
 Disposer143
 Dough Divider & Rounder95
 Draft Beer Dispenser152
 Drawer Warmer.....116
 Drive-Thru Air Curtain19
 Drop-In Cold Well.....167, 168
 Drop-In Hot Well165-168, 170
 Dry Soup Well115
 Dual Temp Reach-In6, 8
 Dunnage Rack129

E

Electric Utility Cart128
 Equipment Dolly162
 Equipment Stand127, 162
 Espresso Machine.....163, 164
 Exhaust Hood.....83

F

Faucet.....140
 Faucet, Add-On.....139
 Flake Ice Machine.....46, 47, 49
 Flatware Bin.....143
 Floor Trough135, 136
 Food Prep Table.....39
 Food Processor.....120, 121, 123
 Food Warmer114-116, 167
 Freezer, Reach-In5-10
 Freezer, Undercounter31
 Freezer, Worktop35
 French Fry Cutter.....121
 Fried Food Holder97, 115
 Frozen Drink Machine.....162, 163
 Fryer.....74-80
 Fryer Dump Station77
 Fryer Filter, Portable.....81
 Fryer w/Filtration75-77, 79
 Fryer, Countertop.....112, 113
 Furniture.....173-179

G

Gas Connector Kit.....81
 Glass Door Merchandiser.....21-27, 30

Glass Froster153, 154
 Glass Rinser.....159
 Glasswasher.....148, 150, 151
 Granita Machine.....164
 Griddle.....85-88
 Griddle Platen.....86
 Griddle Stand.....34
 Gyro Machine.....110

H

Hand Sink136, 137, 140, 160
 Heated Buffet Warmer165
 Heated Display Case.....66
 Heated Holding Cabinet64-67
 Heated Pan Carrier.....171
 High Speed Oven99, 101, 102, 106-108
 Holding & Transport Oven.....64
 Holding Cabinet.....170
 Holding/Proofing Cabinet.....65
 Hose Reel.....140
 Hot Dog Roller Grill90
 Hot Food Table165-167, 169, 170
 Hot Fridge.....108
 Hot Plate.....90
 Hotel Ice Dispenser46

I

Ice & Water Dispenser.....47
 Ice Bin.....159
 Ice Cream Merchandiser.....25
 Ice Machine42-49
 Ice Machine Cleaning System.....45
 Ice Machine Virus Eliminator45
 Ice Storage Bin42, 44, 46, 48
 Immersion Blender.....122-124
 Impinger Oven102, 103
 Induction Cooker.....114
 Induction Food Warmer.....114-116
 Insulated Pan Carrier.....171





J

Juice Dispenser163
 Juicer 124-125

K

Keg Cooler..... 152
 Kitchen Utility Distribution System83
 Kitchen Ventilation 82-84

L

Lettuce Dryer.....125

M

Microwave Oven.....98-100
 Milk Merchandiser.....29
 Mixer.....117, 118
 Mixer Stand..... 127
 Mixology Station..... 159
 Mop Sink.....136
 Mop Sink Cabinet.....135
 Mug Froster153, 154
 Multi-Temp Merchandiser29

N

Nugget Ice Machine..... 46, 47, 49

O

Open Air Merchandiser22, 25-29
 Oven.....104
 Oven Cleaning Kit.....110

P

Packaged Meats Merchandiser.....26
 Pan Rack.....129
 Panini Grill91-93
 Panini Press Kit.....92
 Pass-Thru Air Curtain.....19
 Pass-Thru Refrigerator.....8
 Pasta Cooker..... 72
 Pizza Oven 61, 62, 105
 Pizza Prep Table..... 36, 40, 41
 Pizza Spinner/Spreader95
 Pizza/Pretzel Oven105
 Planetary Mixer117, 118
 Pot Washer 147
 Power Mixer.....122
 Power Soak System141
 Pre-Rinse Spray Head139
 Pre-Rinse Unit.....139, 140
 Prep Table 127

R

Rack Drying Shelf.....144
 Rapid Cook Oven.....101, 102
 Reach-In.....5-10
 Recycling Container.....135
 Red Meat Service Case25
 Refrigerated Cocktail Prep Station..... 154-156
 Refrigerated Countertop Rail35
 Refrigerated Drink Machine.....163
 Refrigerated Equipment Stand 32-34
 Refrigerated Pan Carrier.....171
 Refrigeration System for Walk-In.....18
 Refrigerator, Reach-In5-10
 Refrigerator, Undercounter30-32
 Refrigerator, Worktop33-35
 Restaurant Range50-54
 Rethermalizer 111
 Rice Cooker/Warmer.....114
 Roll-Thru Refrigerator.....8
 Rotating Oven60

S

Salad Prep Table.....37-39
 Salad Spinner125
 Salamander Broiler 51, 52, 90, 91
 Sandwich Grill.....91-93
 Sandwich Prep Table.....35-39
 Self-Serve Merchandiser21-31
 Serving Cart171
 Shawarma Machine110
 Shelving.....130-134
 Shock Freezer20
 Sink136, 137
 Slicer.....118, 119
 Soak Sink.....137
 Soda Dispenser Cabinet127
 Soft Serve Machine4
 Soiled Tray Conveyor System138
 Soup Warmer.....115
 Sous Vide Immersion Circulator110
 Spiral Mixer117, 118
 Steam Table.....165-167, 169, 170
 Steamer71-73, 111, 112
 Strip Warmer115

T

Table177, 179
 Table Base..... 175, 177
 Table Top..... 175, 177
 Tilting Braising Pan..... 68-70
 Tilting Kettle 68-70
 Tilting Skillet.....67, 70

Toaster, Conveyor.....95, 96
 Trash Can135

U

Umbrella.....178
 Underbar Hand Sink.....160
 Underbar Sink.....158-160
 Underbar System.....157, 158
 Undercounter Freezer31
 Undercounter Ice Machine.....42, 45, 47, 48
 Undercounter Refrigerator.....30-32
 Utility Cart.....128, 133, 172
 Utility Distribution Center83

V

Vacuum Sealer.....97
 Vegetable Dryer125
 Vegetable Prep Workstation.....122
 Vegetable Slicer/Cutter120
 Ventilation, Kitchen82-84
 Vertical Cutter Mixer122

W

Waffle Maker94
 Walk-In.....10-17
 Walk-In Beer Cooler152
 Walk-In Door12
 Walk-In Refrigeration System18
 Wall Cabinet.....128
 Wall Shelf Kit.....131, 133
 Warming Cabinet.....66
 Waste Container135
 Wine Cabinet.....154, 155
 Work Table.....126, 127
 Worktop Freezer35
 Worktop Refrigerator33-35

Produced by: CFI Marketing, Inc. - 2026



5061 E ARROW HWY, MONTCLAIR, CA 91763
(909) 621-7428

www.ArrowRestE.com



WE ARE NOT RESPONSIBLE FOR TYPOGRAPHICAL ERRORS OR OMISSIONS. NOT ALL ITEMS ARE IN STOCK AND MAY NOT BE AVAILABLE. SOME ITEMS ARE SPECIAL ORDER AND ARE SUBJECT TO CASE PACK QUANTITIES ONLY. PLEASE INQUIRE WITH YOUR SALESPERSON. IMAGES MAY NOT ACCURATELY REPRESENT ITEMS AND ARE MEANT FOR ILLUSTRATIVE PURPOSES ONLY.

YOUR GO-TO EQUIPMENT EXPERTS

From reach-ins to microwaves—reliable equipment you can count on.

